

APPENDIX 95B

UNITIZATION PROCEDURES FOR BOXED AMMUNITION AND COMPONENTS ON 4-WAY ENTRY PALLETS

MINE, ANTITANK, HEAVY, M15, PACKED 1 PER
WOODEN BOX, UNITIZED 30 BOXES PER 35" X
45 1/2" PALLET; APPROX BOX SIZE 18" L X 15" W
X 7 1/2" H

PALLET UNIT DATA						
ITEMS INCLUDED		HAZARD CLASSIFICATION ^①				WEIGHT (LBS)
NSN	DODIC	DOT CLASS	CG CLASS	QD CLASS	COMP GROUP	
1345- 00-028-5118	K180	A	VII	1.1	D	1,540
00-173-2715	K180	A	VII	1.1	D	1,540
01-142-3441	K180	A	VII	1.1	D	1,540

REVISION

REVISION NO. 1, DATED MAY 1986, CONSISTS OF:
ADDING ITEMS BY NATIONAL STOCK NUMBER TO THE
"PALLET UNIT DATA" CHART.

NOTICE: THIS APPENDIX CANNOT STAND ALONE BUT MUST
BE USED IN CONJUNCTION WITH THE BASIC UNITIZATION
PROCEDURES DRAWING 19-48-4116-20PA1002.

① HAZARD CLASSIFICATION DATA CONTAINED IN THE ABOVE CHART IS FOR GUIDANCE AND INFORMATIONAL PURPOSES ONLY. VERIFICATION OF THE SPECIFIED DATA SHOULD BE MADE BY CONSULTING THE MOST RECENT JOINT HAZARD CLASSIFICATION SYSTEM LISTING OR OTHER APPROVED LISTING (S).

DO NOT SCALE

REVISIONS		DATE	BY	CHECKED BY	APPROVED BY
1	MAY 86	NRE WRE	<i>William F. Smith</i>	<i>RSM</i>	<i>James H. Kelly</i> <i>David F. Feltner</i>
<small>APPROVED BY ORDER OF COMMANDER GENERAL, U. S. ARMY MATERIEL DEVELOPMENT AND READINESS COMMAND (DARCOM)</small> <small>U. S. ARMY MATERIEL DEVELOPMENT AND READINESS CENTER AND SCHOOL</small> U. S. ARMY DARCOM DRAWING JULY 1979					
CLASS	DIVISION	DRAWING	FILE		
19	48	4116/95B	20PA 1002		

GENERAL NOTES

- A. THIS APPENDIX CANNOT STAND ALONE BUT MUST BE USED IN CONJUNCTION WITH THE BASIC UNITIZATION PROCEDURES DRAWING 19-48-4116-20PA1002. TO PRODUCE AN APPROVED UNIT LOAD, ALL PERTINENT PROCEDURES, SPECIFICATIONS AND CRITERIA SET FORTH WITHIN THE BASIC DRAWING WILL APPLY TO THE PROCEDURES DELINEATED IN THIS APPENDIX. ANY EXCEPTIONS TO THE BASIC PROCEDURES ARE SPECIFIED IN THIS APPENDIX.
- B. DIMENSIONS, CUBE AND WEIGHT OF A PALLET UNIT WILL VARY SLIGHTLY DEPENDING UPON THE ACTUAL DIMENSIONS OF THE BOXES AND THE WEIGHT OF THE SPECIFIC ITEM BEING UNITIZED.
- C. INSTALL EACH HORIZONTAL STRAP TO ENCIRCLE A LAYER OF BOXES ON THE PALLET. HORIZONTAL STRAPS MUST BE TENSIONED AND SEALED PRIOR TO APPLICATION OF TIEDOWN STRAPS.
- D. INSTALL EACH TIEDOWN STRAP TO PASS UNDER THE TOP DECK BOARDS OF THE PALLET AND TO BE LOCATED AS SHOWN. TIEDOWN STRAPS WILL NOT BE APPLIED UNTIL THE HORIZONTAL STRAPS HAVE BEEN TENSIONED AND SEALED.
- E. THE FOLLOWING AMC (DARCOM) DRAWINGS ARE APPLICABLE FOR OUTLOADING AND STORAGE OF THE ITEMS COVERED BY THIS APPENDIX.
 - CARLOADING _____ DRAWING 19-48-4115-5PA1002
 - TRUCKLOADING _____ DRAWING 19-48-4117-11PA1003
 - STORAGE _____ DRAWING 19-48-4118-1-2-3-4-14-22PA1002
- F. FOR METHOD OF SECURING A STRAP CUTTER TO THE PALLET UNIT, SEE DARCOM DRAWING 19-48-4127-20P1000.
- G. IF ITEMS COVERED HEREIN ARE UNITIZED PRIOR TO ISSUANCE OF THIS APPENDIX, THE BOXES NEED NOT BE REUNITIZED SOLELY TO CONFORM TO THIS APPENDIX.
- H. THE UNITIZATION PROCEDURES DEPICTED HEREIN MAY ALSO BE USED FOR UNITIZING ANTITANK MINES WHEN IDENTIFIED BY DIFFERENT NATIONAL STOCK NUMBERS (NSN) THAN WHAT IS SHOWN ON THE TITLE PAGE, PROVIDED THE BOX PACK DOES NOT VARY FROM WHAT IS DELINEATED HEREIN. THE EXPLOSIVE CLASSIFICATION OF OTHER ITEMS MAY BE DIFFERENT THAN WHAT IS SHOWN.

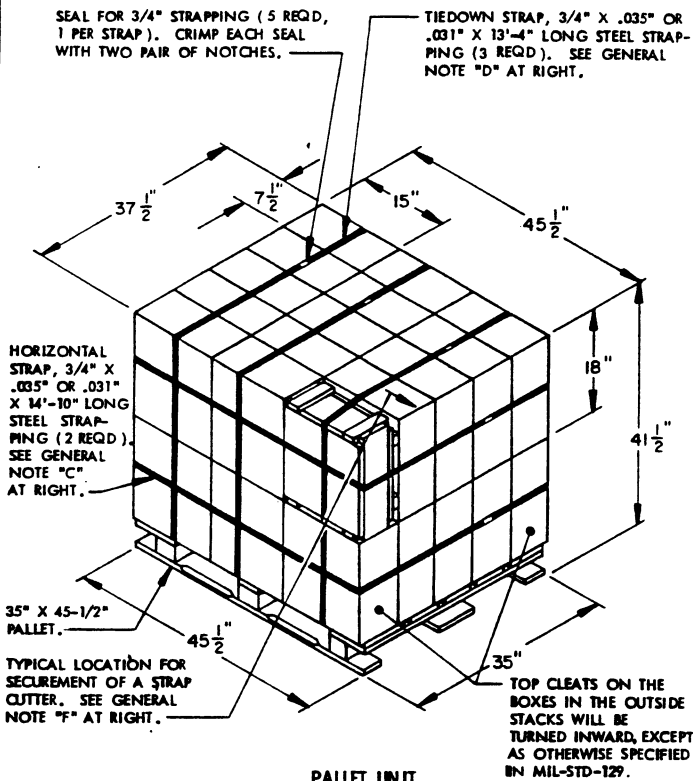

PALLET UNIT

SEE GENERAL NOTE "B" AT RIGHT.

30 BOXES OF MINE, ANTITANK (1 PER BOX) @ 49 LBS — 1,470 LBS (APPROX)
 DUNNAGE _____ 5 LBS
 PALLET _____ 65 LBS

TOTAL WEIGHT _____ 1,540 LBS (APPROX)
 CUBE _____ 41.0 CU FT (APPROX)

BILL OF MATERIAL

PALLET, 35" X 45-1/2"	1 REQD	65 LBS
STEEL STRAPPING, 3/4"	69.67 REQD	4.98 LBS
SEAL FOR 3/4" STRAPPING	5 REQD	NIL

TIE PIECE, 1" X 4" X BOX HEIGHT (2 REQD). NAIL TO LONGITUDINAL PIECES W/2-6d NAILS AT EACH END AND TO LATERAL PIECES W/1-6d NAIL.

BOX HEIGHT

BOX WIDTH

BOX LENGTH

VERTICAL PIECE, 2" X 4" X BOX LENGTH MINUS 3/4" (4 REQD).

LONGITUDINAL PIECE, 2" X 4" X BOX WIDTH (4 REQD). NAIL TO VERTICAL PIECES W/2-10d NAILS AT EACH END.

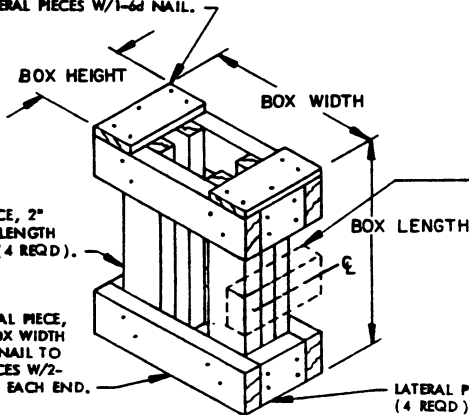

FILLER ASSEMBLY
(FOR MINUS ONE BOX)