

APPENDIX 95

UNITIZATION PROCEDURES FOR BOXED AMMUNITION AND COMPONENTS ON 4-WAY ENTRY PALLETS

MINE, ANTITANK, HE, LIGHT, M7A2, PACKED TWELVE
PER WOODEN BOX, UNITIZED 24 BOXES PER 35" X
45 $\frac{1}{2}$ " PALLET; APPROX BOX SIZE 23 $\frac{3}{8}$ " L X 11 $\frac{3}{4}$ " W X
9 $\frac{1}{2}$ " H

PALLET UNIT DATA						
ITEMS INCLUDED		HAZARD CLASSIFICATION				WEIGHT (LBS)
NSN	DODIC	DOT CLASS	CG CLASS	QD CLASS	COMP GROUP	
1345-00- 028-510B	K170	A	VII	7	G	1,920

NOTICE: THIS APPENDIX CANNOT STAND ALONE BUT MUST BE
USED IN CONJUNCTION WITH THE BASIC UNITIZATION
PROCEDURES DRAWING 19-48-4116-20PA1002.

REVISIONS				DRAFTSMAN GRS / <i>[Signature]</i>	PROJ ENG MWD / <i>[Signature]</i>
				CHECKED dhw / <i>[Signature]</i>	LOG ENGINE OFFICE JCB / <i>[Signature]</i>
				APPROVED, U. S. ARMY ARMAMENT MATERIAL READINESS COMMAND <i>[Signature]</i> <i>[Signature]</i>	
				DRBAR - MAG	DRBAR - TMA
				APPROVED BY ORDER OF COMMANDING GENERAL, U. S. ARMY MATERIEL DEVELOPMENT AND READINESS COMMAND (DARCOM) <i>[Signature]</i> DARCOM AMMO CENTER	
U. S. ARMY DARCOM DRAWING					
APRIL 1977					
				CLASS	DIVISION
				DRAWING	FILE
				19	48
				4116/95	20PA 1002

DO NOT SCALE

TIEDOWN STRAP, 3/4" X .035" OR .031" X 14'-0" LONG STEEL STRAPPING (4 REQD.). SEE GENERAL NOTE "D" AT RIGHT.

SEAL FOR 3/4" STRAPPING (7 REQD., 1 PER STRAP). CRIMP EACH SEAL WITH TWO PAIR OF NOTCHES.

TOP CLEATS ON THE BOXES IN THE OUTSIDE STACKS WILL BE TURNED INWARD.

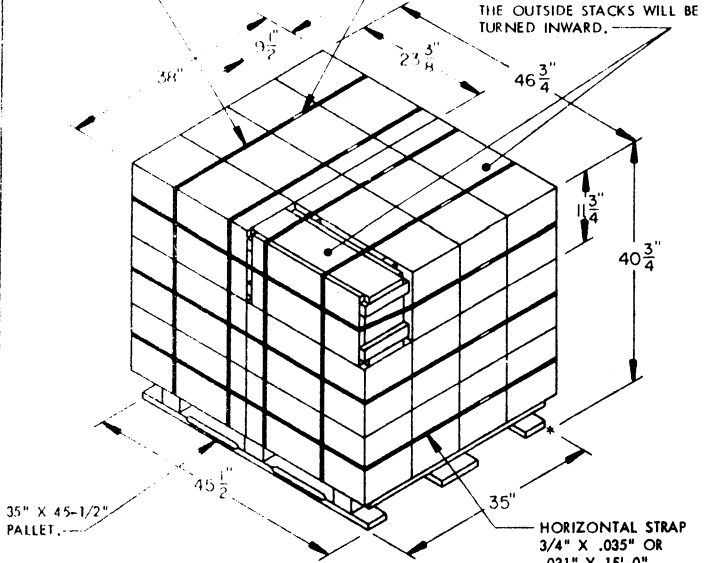

PALLET UNIT

SEE GENERAL NOTE "B" AT RIGHT.

HORIZONTAL STRAP 3/4" X .035" OR .031" X 15'-0" LONG STEEL STRAPPING (3 REQD.). SEE GENERAL NOTE "C" AT RIGHT.

GENERAL NOTES

- A. THIS APPENDIX CANNOT STAND ALONE BUT MUST BE USED IN CONJUNCTION WITH THE BASIC UNITIZATION PROCEDURES DRAWING 19-48-4116-20PA1002. TO PRODUCE AN APPROVED UNIT LOAD, ALL PERTINENT PROCEDURES, SPECIFICATIONS AND CRITERIA SET FORTH WITHIN THE BASIC DRAWING WILL APPLY TO THE PROCEDURES DELINEATED IN THIS APPENDIX. ANY EXCEPTIONS TO THE BASIC PROCEDURES ARE SPECIFIED IN THIS APPENDIX.
- B. DIMENSIONS, CUBE AND WEIGHT OF A PALLET UNIT WILL VARY SLIGHTLY DEPENDING UPON THE ACTUAL DIMENSIONS OF THE BOXES AND THE WEIGHT OF THE SPECIFIC ITEM BEING UNITIZED.
- C. INSTALL EACH HORIZONTAL STRAP TO ENCIRCLE EACH LAYER OF BOXES ON THE PALLET. HORIZONTAL STRAPS MUST BE TENSIONED AND SEALED PRIOR TO APPLICATION OF TIEDOWN STRAPS.
- D. INSTALL EACH TIEDOWN STRAP TO PASS UNDER THE TOP DECK BOARDS OF THE PALLET AND TO BE LOCATED AS SHOWN. TIEDOWN STRAPS WILL NOT BE APPLIED UNTIL THE HORIZONTAL STRAPS HAVE BEEN TENSIONED AND SEALED.
- E. THE FOLLOWING DARCOM DRAWINGS ARE APPLICABLE FOR OUTLOADING AND STORAGE OF THE ITEMS COVERED BY THIS APPENDIX.
 - CARLOADING ----- DRAWING 19-48-4115-SPA1002
 - TRUCKLOADING --- DRAWING 19-48-4117-11PA1003
 - STORAGE ----- DRAWING 19-48-4118-1-2-14-22PA1002
- F. FOR METHOD OF SECURING A STRAP CUTTER TO THE PALLET UNIT, SEE DARCOM DRAWING 19-48-4127-20P1000.
- G. IF ITEMS COVERED HEREIN ARE UNITIZED PRIOR TO ISSUANCE OF THIS APPENDIX, THE BOXES NEED NOT BE REUNITIZED SOLELY TO CONFORM TO THIS APPENDIX.
- H. THE UNITIZATION PROCEDURES DEPICTED HEREIN MAY ALSO BE USED FOR UNITIZING ANTITANK MINES WHEN IDENTIFIED BY A DIFFERENT NATIONAL STOCK NUMBER (NSN) THAN THOSE SHOWN ON THE TITLE PAGE, PROVIDED THE BOX PACK DOES NOT VARY FROM THOSE SHOWN HEREIN. THE EXPLOSIVE CLASSIFICATION OF OTHER ITEMS MAY BE DIFFERENT THAN THOSE SHOWN.

24 BOXES OF MINE, ANTITANK (12 PER BOX) @ 77 LBS	-----	1,848 LBS (APPROX)
DUNNAGE	-----	7 LBS
PALLET	-----	65 LBS
TOTAL WEIGHT	-----	1,920 LBS (APPROX)
CUBE	-----	41.8 CU FT (APPROX)

BILL OF MATERIAL

PALLET, 35" X 45-1/2"	-----	1 REQD	-----	65 LBS
STEEL STRAPPING, 3/4"	-----	99" REQD	-----	7 LBS
SEAL FOR 3/4" STRAPPING	-----	7 REQD	-----	NIL

LATERAL PIECE, 2" X 6" X BOX HEIGHT MINUS 3" (4 REQD.). NAIL TO VERTICAL PIECES W/2-10d NAILS AT EACH END.

VERTICAL PIECE, 2" X 4" X BOX WIDTH (4 REQD.).

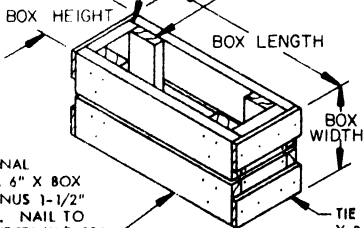

LONGITUDINAL PIECE, 2" X 6" X BOX LENGTH MINUS 1-1/2" (4 REQD.). NAIL TO VERTICAL PIECES W/3-10d NAILS AT EACH END.

TIE PIECE, 1" X 4" X BOX HEIGHT (4 REQD.). NAIL TO LONGITUDINAL PIECES W/1-6d NAIL AT EACH END AND TO LATERAL PIECES W/2-6d NAILS.

FILLER ASSEMBLY A
(FOR MINUS ONE BOX)

LATERAL PIECE, 2" X 6" X BOX HEIGHT X 2 MINUS 3" (4 REQD.). NAIL TO VERTICAL PIECES W/2-10d NAILS AT EACH END.

VERTICAL PIECE, 2" X 4" X BOX WIDTH (4 REQD.).

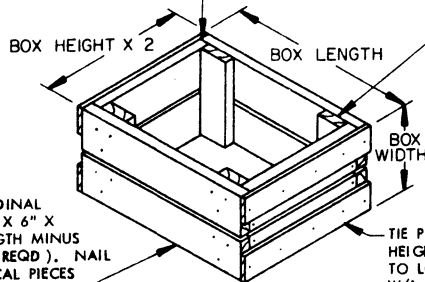

LONGITUDINAL PIECE, 2" X 6" X BOX LENGTH MINUS 1-1/2" (4 REQD.). NAIL TO VERTICAL PIECES W/3-10d NAILS AT EACH END.

TIE PIECE, 1" X 4" X BOX HEIGHT X 2 (4 REQD.). NAIL TO LONGITUDINAL PIECES W/1-6d NAIL AT EACH END AND TO LATERAL PIECES W/3-6d NAILS.

FILLER ASSEMBLY B
(FOR MINUS 2 BOXES)