

# APPENDIX 8R

## UNITIZATION PROCEDURES FOR BOXED AMMUNITION AND COMPONENTS ON 4-WAY ENTRY PALLETS

CARTRIDGE, CALIBER .30, PACKED VARIOUS  
QUANTITIES PER M19 SERIES METAL CONTAINERS,  
4 PER WIREBOUND BOX, UNITIZED 20 BOXES  
PER 35" X 45 $\frac{1}{2}$ " PALLET; APPROX BOX SIZE  
17 $\frac{1}{2}$ " L X 11 $\frac{1}{2}$ " W X 7 $\frac{3}{4}$ " H

PALLET UNIT DATA						
ITEMS INCLUDED		HAZARD CLASSIFICATION <sup>①</sup>				WEIGHT
NSN	DODIC	DOT CLASS	CG CLASS	QD CLASS	COMP GROUP	( LBS )
1305-00-126-3856	A205	C	I	1.4	5	1,870

① HAZARD CLASSIFICATION DATA CONTAINED IN THE ABOVE CHART IS FOR GUIDANCE AND INFORMATIONAL PURPOSES ONLY. VERIFICATION OF THE SPECIFIED DATA SHOULD BE MADE BY CONSULTING THE MOST RECENT JOINT HAZARD CLASSIFICATION SYSTEM LISTING OR OTHER APPROVED LISTING(S).

**NOTICE:** THIS APPENDIX CANNOT STAND ALONE BUT MUST BE USED IN CONJUNCTION WITH THE BASIC UNITIZATION PROCEDURES DRAWING 19-48-4116-20PA1002.

### REVISION

REVISION NO. 1, DATED JULY 1984, CONSISTS OF:

DELETING ITEM BY NATIONAL STOCK NUMBER FROM "PALLET UNIT DATA" CHART.

**DO NOT SCALE**

REVISIONS				DRAFTSMAN	PROJ ENG
1	JUL 84	<i>[Signature]</i>	<i>[Signature]</i>	<i>[Signature]</i>	<i>[Signature]</i>
				CHECKER	LOG ENGINEER
				<i>[Signature]</i>	<i>[Signature]</i>
APPROVED, U. S. ARMY ARMAMENT MATERIEL READINESS COMMAND					
				DDBAR - MAP	DDBAR - IHD
				<i>[Signature]</i>	<i>[Signature]</i>
APPROVED BY ORDER OF COMMANDING GENERAL, U. S. ARMY MATERIEL DEVELOPMENT AND READINESS COMMAND (DARCOM)					
<i>[Signature]</i>					
U. S. ARMY DEFENSE AMMUNITION CENTER AND SCHOOL					
U. S. ARMY DARCOM DRAWING					
APRIL 1980					
CLASS	DIVISION	DRAWING	FILE		
19	48	4116/8R	20PA 1002		

**GENERAL NOTES**

- A. THIS APPENDIX CANNOT STAND ALONE BUT MUST BE USED IN CONJUNCTION WITH THE BASIC UNITIZATION PROCEDURES DRAWING 19-48-4116-20PA1002. TO PRODUCE AN APPROVED UNIT LOAD, ALL PERTINENT PROCEDURES, SPECIFICATIONS AND CRITERIA SET FORTH WITHIN THE BASIC DRAWING WILL APPLY TO THE PROCEDURES DELINEATED IN THIS APPENDIX. ANY EXCEPTIONS TO THE BASIC PROCEDURES ARE SPECIFIED IN THIS APPENDIX.
- B. DIMENSIONS, CUBE AND WEIGHT OF A PALLET UNIT WILL VARY SLIGHTLY DEPENDING UPON THE ACTUAL DIMENSIONS OF THE BOXES AND THE WEIGHT OF THE SPECIFIC ITEM BEING UNITIZED.
- C. INSTALL THE HORIZONTAL STRAP TO ENCIRCLE THE LAYER OF BOXES ON THE PALLET. HORIZONTAL STRAP MUST BE TENSIONED AND SEALED PRIOR TO APPLICATION OF TIEDOWN STRAPS.
- D. INSTALL EACH TIEDOWN STRAP TO PASS UNDER THE TOP DECK BOARDS OF THE PALLET. NOTE THAT THE STRAPS WILL BE LOCATED AS DIMENSIONED, NEAR THE SIDE CLEATS OF THE END PANELS OF THE BOX. TIEDOWN STRAPS WILL NOT BE APPLIED UNTIL THE HORIZONTAL STRAPS HAVE BEEN TENSIONED AND SEALED.
- E. THE FOLLOWING DARCOM DRAWINGS ARE APPLICABLE FOR OUTLOADING AND STORAGE OF THE ITEMS COVERED BY THIS APPENDIX.  
 CARLOADING ---- DRAWING 19-48-4115-5PA1002  
 TRUCKLOADING -- DRAWING 19-48-4117-11PA1003  
 STORAGE ----- DRAWING 19-48-4118-1-2-3-4-14-22PA1002
- F. FOR METHOD OF SECURING A STRAP CUTTER TO THE PALLET UNIT, SEE DARCOM DRAWING 19-48-4127-20P1000.
- G. IF ITEMS COVERED HEREIN ARE UNITIZED PRIOR TO ISSUANCE OF THIS APPENDIX, THE BOXES NEED NOT BE REUNITIZED SOLELY TO CONFORM TO THIS APPENDIX.
- H. THE UNITIZATION PROCEDURES DEPICTED HEREIN MAY ALSO BE USED FOR UNITIZING .30 CALIBER CARTRIDGES WHEN IDENTIFIED BY DIFFERENT NATIONAL STOCK NUMBERS (NSN) THAN WHAT IS SHOWN ON THE TITLE PAGE, PROVIDED THE BOX PACK DOES NOT VARY FROM WHAT IS DELINEATED HEREIN. THE EXPLOSIVE CLASSIFICATION OF OTHER ITEMS MAY BE DIFFERENT THAN WHAT IS SHOWN.
- J. IF THERE IS A NEED TO USE FILLER ASSEMBLIES AND AT LEAST TWO PALLET UNITS ARE BEING CONSTRUCTED, NOT MORE THAN 12 FILLERS WILL BE INSTALLED IN ANY ONE PALLET UNIT. ADDITIONAL FILLERS CAN BE PUT IN A SECOND PALLET UNIT AS REQUIRED WHEN THE QUANTITY OF 12 FILLERS IN THE FIRST REDUCED PALLET UNIT IS INSUFFICIENT TO SATISFY THE TOTAL REDUCTION NEEDED. USING TWO PALLET UNITS TO SATISFY THE PALLETIZATION CRITERIA APPLICABLE TO LESS-THAN-FULL PALLET UNITS IS AN EXCEPTION TO THE BASIC PROCEDURES. HOWEVER, THE EXCEPTION IS NECESSARY FOR THE AMMUNITION PACK COVERED BY THIS APPENDIX, TO MOST EFFECTIVELY GET AN ACCEPTABLE, COMPACT AND SOUND PALLET UNIT.

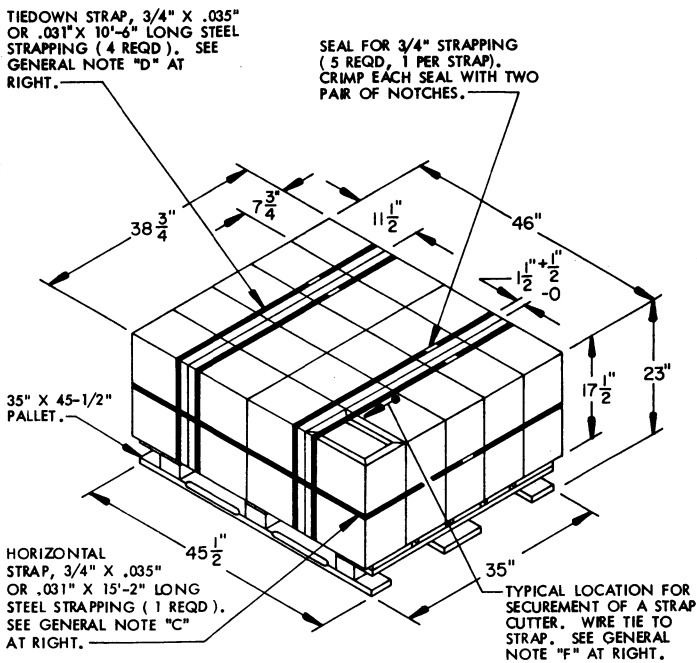

**PALLET UNIT**

SEE GENERAL NOTE "B" AT RIGHT

20 BOXES OF .30 CALIBER CARTRIDGE ( VARIOUS QUANTITIES PER BOX ) @ 90 LBS --	1,800 LBS ( APPROX )
DUNNAGE -----	5 LBS
PALLET -----	65 LBS
<b>TOTAL WEIGHT -----</b>	<b>1,870 LBS ( APPROX )</b>
<b>CUBE -----</b>	<b>23.7 CU FT ( APPROX )</b>

**BILL OF MATERIAL**

PALLET, 35" X 45-1/2" -----	1 REQD -----	65 LBS
STEEL STRAPPING, 3/4" -----	57.17' REQD -----	4.08 LBS
SEAL FOR 3/4" STRAPPING -----	5 REQD -----	NIL

LATERAL PIECE, 2" X 4" X BOX HEIGHT ( 4 REQD ). NAIL TO LONGITUDINAL PIECES W/2-10d NAILS AT EACH END.

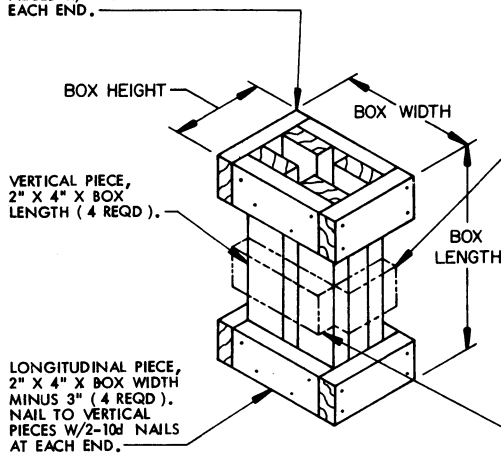

**FILLER ASSEMBLY**

( FOR MINUS ONE BOX )

( SEE GENERAL NOTE "J" ABOVE )

STRAP BEARING PIECE, 2" X 4" X BOX HEIGHT MINUS 3" ( AS REQD ). NAIL TO VERTICAL PIECES W/2-10d NAILS AT EACH END. NOTE: WHEN THE FILLER ASSEMBLY OR ASSEMBLIES ARE LOCATED IN AN OUTER STACK ON THE 35" SIDE OR SIDES OF THE PALLET, IT WILL REQUIRE A "STRAP BEARING PIECE" POSITIONED UNDER THE HORIZONTAL STRAP. STAPLE STRAP TO THE "STRAP BEARING PIECE".

STRAP BEARING PIECE, 2" X 4" X BOX WIDTH MINUS 3" ( AS REQD ). NAIL TO THE VERTICAL PIECES W/2-10d NAILS AT EACH END. NOTE: WHEN THE FILLER ASSEMBLY OR ASSEMBLIES ARE LOCATED IN AN OUTER STACK ON THE 45-1/2" SIDE OR SIDES OF THE PALLET UNIT, IT WILL REQUIRE A "STRAP BEARING PIECE" POSITIONED UNDER THE HORIZONTAL STRAP. STAPLE STRAP TO THE "STRAP BEARING PIECE".