

APPENDIX 8P

UNITIZATION PROCEDURES FOR BOXED AMMUNITION AND COMPONENTS ON 4-WAY ENTRY PALLETS

CARTRIDGE, CALIBER .30, PACKED 1200 PER
WOODEN BOX, UNITIZED 36 BOXES PER 40" X
48" PALLET; APPROX BOX SIZE 14 $\frac{5}{8}$ " L X
10 $\frac{1}{4}$ " W X 8 $\frac{5}{8}$ " H

PALLET UNIT DATA						
ITEMS INCLUDED		HAZARD CLASSIFICATION				WEIGHT (LBS)
NSN	DODIC	DOT CLASS	CG CLASS	QD CLASS	COMP GROUP	
1305-						
00-028-6509	A182	C	I	1.4	S	2,032
00-028-6510	A184	C	I	1.4	S	2,032
00-554-1335	A182	C	I	1.4	S	2,032

NOTICE: THIS APPENDIX CANNOT STAND ALONE BUT MUST
BE USED IN CONJUNCTION WITH THE BASIC UNITIZATION
PROCEDURES DRAWING 19-48-4116-20PA1002.

REVISIONS				DESIGNED GRG/SK	FIELD USE WRF/MSW
				CHECKED PSA	LOG ENTRY OFFICE <i>John R. ...</i>
APPROVED, U. S. ARMY ARMAMENT MATERIEL READINESS COMMAND					
			<i>Lawrence Kuster</i> DSAR - MAG		<i>Donald C. Feltus</i> DSAR - TMS
APPROVED BY ORDER OF COMMANDING GENERAL, U. S. ARMY MATERIEL DEVELOPMENT AND READINESS COMMAND (DARCOM)					
<i>John J. ...</i> U. S. ARMY DEFENSE AMMUNITION CENTER AND SUPPORT					
U.S. ARMY DARCOM DRAWING					
APRIL 1980					
CLASS	DIVISION	DRAWING	FILE		
19	48	4116/8P	20PA 1002		

DO NOT SCALE

GENERAL NOTES

TIEDOWN STRAP, 3/4" X .035" OR .031" X 11'-10" LONG STEEL STRAPPING (6 REQD). SEE GENERAL NOTE "D" AT RIGHT.

TOP CLEATS ON THE BOXES IN THE OUTWARD STACKS WILL BE TURNED INWARD.

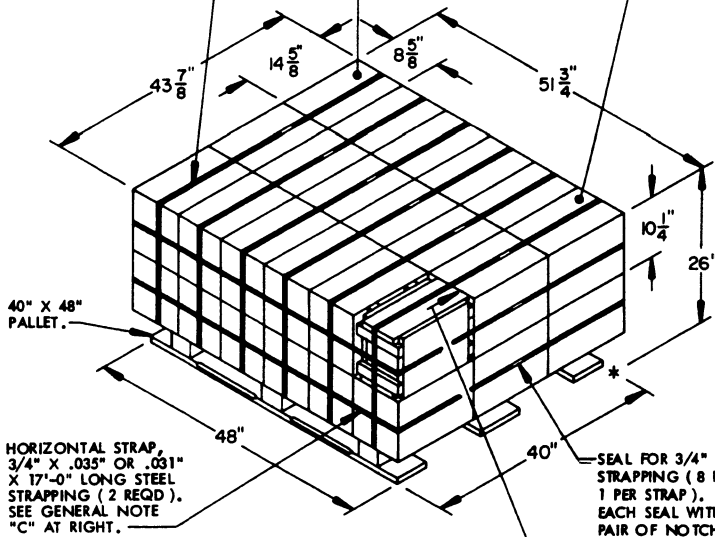

- A. THIS APPENDIX CANNOT STAND ALONE BUT MUST BE USED IN CONJUNCTION WITH THE BASIC UNITIZATION PROCEDURES DRAWING 19-48-4116-20PA1002. TO PRODUCE AN APPROVED UNIT LOAD, ALL PERTINENT PROCEDURES, SPECIFICATIONS AND CRITERIA SET FORTH WITHIN THE BASIC DRAWING WILL APPLY TO THE PROCEDURES DELINEATED IN THIS APPENDIX. ANY EXCEPTIONS TO THE BASIC PROCEDURES ARE SPECIFIED IN THIS APPENDIX.
- B. DIMENSIONS, CUBE AND WEIGHT OF A PALLET UNIT WILL VARY SLIGHTLY DEPENDING UPON THE ACTUAL DIMENSIONS OF THE BOXES AND THE WEIGHT OF THE SPECIFIC ITEM BEING UNITIZED.
- C. INSTALL EACH HORIZONTAL STRAP TO ENCIRCLE A LAYER OF BOXES ON THE PALLET. HORIZONTAL STRAPS MUST BE TENSIONED AND SEALED PRIOR TO APPLICATION OF TIEDOWN STRAPS.
- D. INSTALL EACH TIEDOWN STRAP TO PASS UNDER THE DECK/STRINGER BOARDS OF THE PALLET AND TO BE LOCATED AS SHOWN. TIEDOWN STRAPS WILL NOT BE APPLIED UNTIL THE HORIZONTAL STRAPS HAVE BEEN TENSIONED AND SEALED.
- E. THE FOLLOWING DARCOM DRAWINGS ARE APPLICABLE FOR UNLOADING AND STORAGE OF THE ITEMS COVERED BY THIS APPENDIX.

CARLOADING -----	DRAWING 19-48-4115-5PA1002
TRUCKLOADING -----	DRAWING 19-48-4117-11PA1003
STORAGE -----	DRAWING 19-48-4118-1-2-14-22PA1002
- F. FOR METHOD OF SECURING A STRAP CUTTER TO THE PALLET UNIT, SEE DARCOM DRAWING 19-48-4127-20P1000.
- G. IF ITEMS COVERED HEREIN ARE UNITIZED PRIOR TO ISSUANCE OF THIS APPENDIX, THE BOXES NEED NOT BE REUNITIZED SOLELY TO CONFORM TO THIS APPENDIX.
- H. THE UNITIZATION PROCEDURES DEPICTED HEREIN MAY ALSO BE USED FOR UNITIZING .30 CALIBER CARTRIDGES WHEN IDENTIFIED BY DIFFERENT NATIONAL STOCK NUMBERS (NSN) THAN WHAT IS SHOWN ON THE TITLE PAGE, PROVIDED THE BOX PACK DOES NOT VARY FROM WHAT IS DELINEATED HEREIN. THE EXPLOSIVE CLASSIFICATION OF OTHER ITEMS MAY BE DIFFERENT THAN WHAT IS SHOWN.

PALLET UNIT

SEE GENERAL NOTE "B" AT RIGHT.

36 BOXES OF .30 CALIBER CARTRIDGE (1200 PER BOX) @ 54 LBS -----	1,944 LBS (APPROX)
DUNNAGE -----	8 LBS
PALLET -----	80 LBS
TOTAL WEIGHT -----	2,032 LBS (APPROX)
CUBE -----	34.2 CU FT (APPROX)

BILL OF MATERIAL

PALLET, 40" X 48" -----	1 REQD -----	80 LBS
STEEL STRAPPING, 3/4" -----	105.00' REQD -----	7.50 LBS
SEAL FOR 3/4" STRAPPING -----	8 REQD -----	NIL

TIE PIECE, 1" X 4" X BOX HEIGHT (2 REQD). NAIL TO LONGITUDINAL PIECES W/1-6d NAIL AT EACH END AND TO LATERAL PIECE W/3-6d NAILS.

VERTICAL PIECE, 2" X 4" X BOX WIDTH MINUS 3/4" (4 REQD).

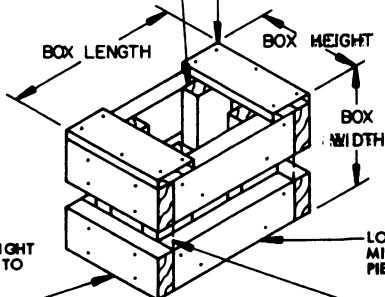

LATERAL PIECE, 2" X 4" X BOX HEIGHT (4 REQD). NAIL TO VERTICAL PIECES W/2-10d NAILS AT EACH END.

LONGITUDINAL PIECE, 2" X 4" BOX LENGTH MINUS 3" (4 REQD). NAIL TO VERTICAL PIECES W/2-10d NAILS AT EACH END.

FILLER ASSEMBLY

(FOR MINUS ONE BOX)

STRAP BEARING PIECE, 2" X 4" (RIPPED TO FIT) X BOX LENGTH MINUS 3" (AS REQD). NAIL TO VERTICAL PIECES W/2-10d NAILS AT EACH END. NOTE: WHEN A UNIT HAS MORE THAN EIGHT (8) BOXES OMITTED, THE FILLER ASSEMBLY OR ASSEMBLIES LOCATED IN AN OUTER STACK ON THE 40" SIDE OR SIDES OF THE PALLET WILL REQUIRE A "STRAP BEARING PIECE" POSITIONED UNDER THE HORIZONTAL STRAP. STAPLE STRAP TO "STRAP BEARING PIECE".