

APPENDIX 8E

UNITIZATION PROCEDURES FOR BOXED AMMUNITION AND COMPONENTS ON 4-WAY ENTRY PALLETS

CARTRIDGE, CALIBER .30, PACKED VARIOUS
QUANTITIES PER WOODEN BOX, UNITIZED 20
BOXES PER 35" X 45 $\frac{1}{2}$ " PALLET; APPROX
BOX SIZE 18 $\frac{1}{2}$ " L X 9 $\frac{1}{2}$ " W X 14 $\frac{7}{8}$ " H

PALLET UNIT DATA						
ITEMS INCLUDED		HAZARD CLASSIFICATION				WEIGHT
NSN	DODIC	DOT CLASS	CG CLASS	QD CLASS	COMP GROUP	(LBS)
1305-						
00-028-6157	A201	C	I	1.4	S	2,332
00-028-6161	A202	C	I	1.4	S	2,332
00-028-6255	A238	C	I	1.4	S	2,272
00-028-6261	A232	C	I	1.4	S	2,312
00-028-6265	A234	C	I	1.4	S	2,232
00-028-6276	A245	C	I	1.4	S	2,232
00-028-6277	A244	C	I	1.4	S	2,312
00-028-6280	A220	C	I	1.4	S	1,572
00-028-6250	A227	C	I	1.4	S	1,572
00-529-8244	A242	C	I	1.4	S	1,532

NOTICE: THIS APPENDIX CANNOT STAND ALONE BUT MUST BE USED IN CONJUNCTION WITH THE BASIC UNITIZATION PROCEDURES DRAWING 19-48-4116-20PA1002.

REVISION

REVISION NO. 1, DATED FEBRUARY 1982, CONSISTS OF:

1. ELIMINATING SPACER ASSEMBLY.
2. ADDING TWO MORE BOXES TO PALLET UNIT.
3. CHANGING UNITIZATION PROCEDURES TO CONFORM TO 1 AND 2 ABOVE.

DO NOT SCALE

REVISIONS				PROJ ENG	LOG ENGRG OFFICE
1	FEB 82	(11)	John L. Byrd	R. S. /	John /
APPROVED BY ORDER OF COMMANDING GENERAL, U. S. ARMY MATERIAL DEVELOPMENT AND READINESS COMMAND (DARCOM)				DARCOM - MAD	
APPROVED BY ORDER OF COMMANDING GENERAL, U. S. ARMY MATERIAL DEVELOPMENT AND READINESS COMMAND (DARCOM)				DARCOM - TMD	
U. S. ARMY DEFENSE AMMUNITION CENTER AND SCHOOL					
APRIL 1980					
CLASS	DIVISION	DRAWING	FILE		
19	48	4116/8E	20PA 1002		

GENERAL NOTES

- A. THIS APPENDIX CANNOT STAND ALONE BUT MUST BE USED IN CONJUNCTION WITH THE BASIC UNITIZATION PROCEDURES DRAWING 19-48-4116-20PA1002. TO PRODUCE AN APPROVED UNIT LOAD, ALL PERTINENT PROCEDURES, SPECIFICATIONS AND CRITERIA SET FORTH WITHIN THE BASIC DRAWING WILL APPLY TO THE PROCEDURES DELINEATED IN THIS APPENDIX. ANY EXCEPTIONS TO THE BASIC PROCEDURES ARE SPECIFIED IN THIS APPENDIX.
- B. DIMENSIONS, CUBE AND WEIGHT OF A PALLET UNIT WILL VARY SLIGHTLY DEPENDING UPON THE ACTUAL DIMENSIONS OF THE BOXES AND THE WEIGHT OF THE SPECIFIC ITEM BEING UNITIZED.
- C. THE LOAD STRAPS WILL BE THREADED THROUGH THE STRAP SLOTS OF A PALLET PRIOR TO PLACING BOXES ON THE PALLET. LOAD STRAPS MUST BE TENSIONED AND SEALED PRIOR TO APPLICATION OF TIEDOWN STRAPS.
- D. INSTALL EACH TIEDOWN STRAP TO PASS UNDER THE DECK/STRINGER BOARDS OF THE PALLET AND TO BE LOCATED AS SHOWN. TIEDOWN STRAPS WILL BE APPLIED BUT NOT TENSIONED UNTIL THE HORIZONTAL STRAPS HAVE BEEN INSTALLED AND TENSIONED.
- E. INSTALL EACH HORIZONTAL STRAP TO ENCIRCLE A LAYER OF BOXES ON THE PALLET. HORIZONTAL STRAPS MUST BE TENSIONED AND SEALED PRIOR TO TENSIONING OF TIEDOWN STRAPS.
- F. THE FOLLOWING DARCOM DRAWINGS ARE APPLICABLE FOR OUTLOADING AND STORAGE OF THE ITEMS COVERED BY THIS APPENDIX.
 CARLOADING -----DRAWING 19-48-4115-5PA1002
 TRUCKLOADING-----DRAWING 19-48-4117-11PA1003
 STORAGE -----DRAWING 19-48-4118-1-2-3-4-14-22PA1002
- G. FOR METHOD OF SECURING A STRAP CUTTER TO THE PALLET UNIT, SEE DARCOM DRAWING 19-48-4127-20P1000.
- H. IF ITEMS COVERED HEREIN ARE UNITIZED PRIOR TO ISSUANCE OF THIS APPENDIX, THE BOXES NEED NOT BE REUNITIZED SOLELY TO CONFORM TO THIS APPENDIX.
- J. THE UNITIZATION PROCEDURES DEPICTED HEREIN MAY ALSO BE USED FOR UNITIZING .30 CALIBER CARTRIDGES WHEN IDENTIFIED BY DIFFERENT NATIONAL STOCK NUMBERS (NSN) THAN WHAT IS SHOWN ON THE TITLE PAGE, PROVIDED THE BOX PACK DOES NOT VARY FROM WHAT IS DELINEATED HEREIN. THE EXPLOSIVE CLASSIFICATION OF OTHER ITEMS MAY BE DIFFERENT THAN WHAT IS SHOWN.

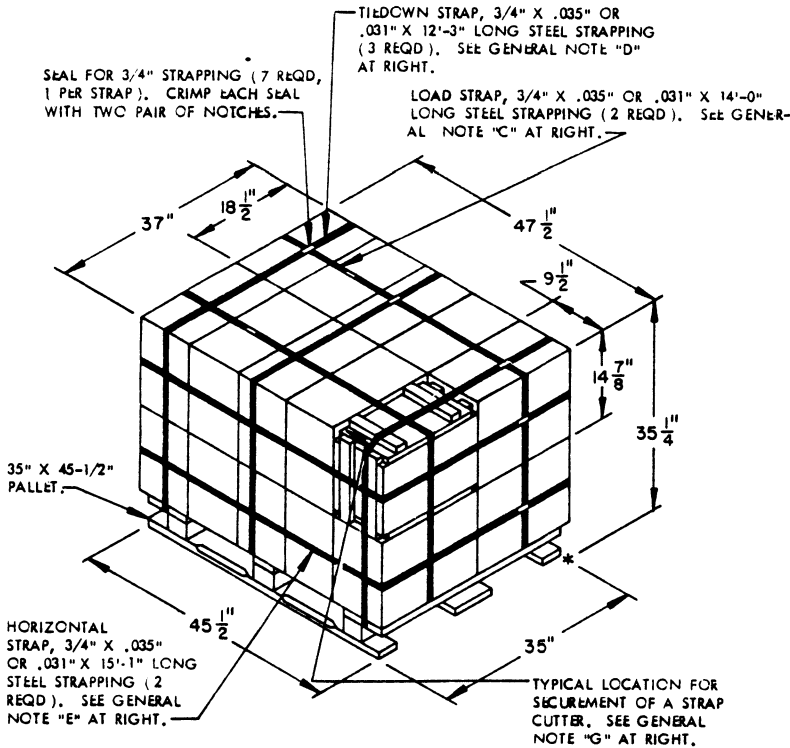

PALLET UNIT

SEE GENERAL NOTE "B" AT RIGHT.

20 BOXES OF .30 CALIBER CARTRIDGE (VARIOUS QUANTITIES)	113 LBS -----	2,260 LBS (APPROX)
DUNNAGE -----	7 LBS	
PALLET -----	65 LBS	
TOTAL WEIGHT-----	2,332 LBS (APPROX)	
CUBE-----	35.9 CU FT (APPROX)	

BILL OF MATERIAL

PALLET, 35" X 45-1/2" -----	1 REQD-----	65 LBS
STEEL STRAPPING, 3/4" -----	94.92 REQD-----	6.78 LBS
SEAL FOR 3/4" STRAPPING -----	7 REQD-----	NIL

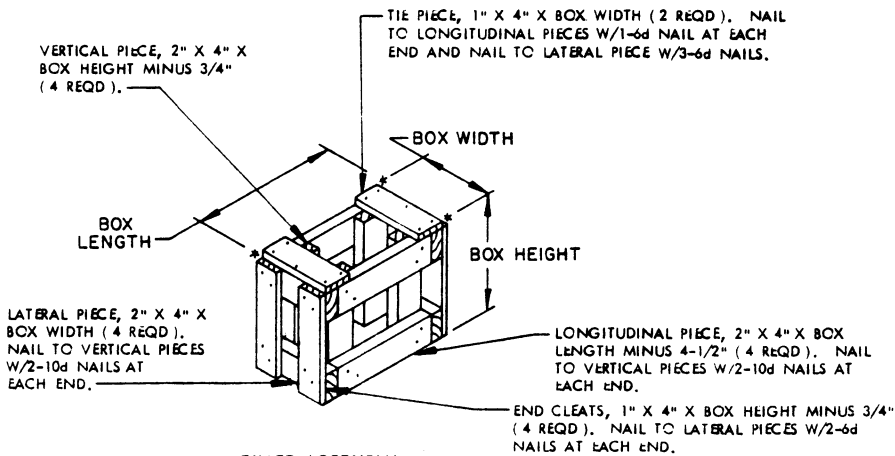

FILLER ASSEMBLY

(FOR MINUS ONE BOX)