

APPENDIX 80Q

UNITIZATION PROCEDURES FOR BOXED AMMUNITION AND COMPO- NENTS ON 4-WAY ENTRY PALLETS

**WARHEAD, 2.75" ROCKET, FLARE, PACKED 6 PER
WOODEN BOX, UNITIZED 15 BOXES PER 35" X
45-1/2" PALLET; APPROX BOX SIZE 48-1/2" L X
12-1/4" W X 9-3/8" H**

**NOTICE: THIS APPENDIX CANNOT STAND ALONE BUT MUST BE USED IN CONJUNCTION WITH THE BASIC UNITIZATION
PROCEDURES DRAWING 19-48-4116-20PA1002.**

DISTRIBUTION STATEMENT A:

**APPROVED FOR PUBLIC RELEASE
DISTRIBUTION IS UNLIMITED.**

U.S. ARMY MATERIEL COMMAND DRAWING

APPROVED, COMBAT CAPABILITIES DEVELOPMENT COMMAND ARMAMENTS CENTER HANSENEN.JO Digitally signed by SEP.H.W.1376 HANSENEN.JOSEPH.W. 495538 1376495538 Date: 2020.09.28 10:03:49 -05'00'	CAUTION: VERIFY PRIOR TO USE AT https://www.dau.edu/cop/ammo/Pages/Default.aspx THAT THIS IS THE MOST CURRENT VERSION OF THIS DOCUMENT. THIS IS PAGE 1 OF 4.		DO NOT SCALE		OCTOBER 1997			
APPROVED, U.S. ARMY JOINT MUNITIONS COMMAND WARD.GINA. Digitally signed by M.1369379808 WARD.GINA.M.1369379808 AMSJM-MLT Date: 2020.09.29 12:14:07 -05'00'	DESIGN ENGINEER	BASIC REV.	SANDRA M. SCHULTZ SPENCER HOVEY		REVISION NO. 2	AUGUST 2020		
APPROVED BY ORDER OF COMMANDING GENERAL, U.S. ARMY MATERIEL COMMAND SMITH.THERESA. Digitally signed by ANN.1009147639 SMITH.THERESA.ANN.1009147 639 Date: 2020.10.13 14:07:59 -05'00' U.S. ARMY DEFENSE AMMUNITION CENTER	ENGINEERING DIVISON	FIEFFER.LAUR Digitally signed by A.A.1230375727 FIEFFER.LAURA.A.1230375727 Date: 2020.08.18 07:55:48 -05'00'		SEE THE REVISION LISTING ON PAGE 2				
	TEST ENGINEER TEST REPORT	NA	FELICIANO.AD Digitally signed by IN.1259200373 FELICIANO.ADIN.1259200373 Date: 2020.08.24 15:16:24 -05'00'		CLASS	DIVISION	DRAWING	FILE
	EXPLOSIVE SAFETY DIRECTORATE	THOMAS.CARL.AN Digitally signed by THONY.1104621372 THOMAS.CARL.ANTHONY.11046 21372 Date: 2020.08.26 07:16:42 -05'00'		19	48	4116/ 80Q	20PA1002	

PALLET UNIT DATA				
ITEMS INCLUDED		*HAZARD CLASS AND DIVISION	*COMPATIBILITY GROUP	APPROX WEIGHT (LBS)
NSN	DODIC			
1340-				
01-456-0978	H812	1. 2. 1	G	1, 933
01-443-3583	HA06	1. 2. 1	G	1, 933
01-684-8166	HB37	1. 2. 1	G	1, 933

*HAZARD CLASSIFICATION DATA CONTAINED IN THE ABOVE CHART IS FOR GUIDANCE AND INFORMATIONAL PURPOSES ONLY. VERIFICATION OF THE SPECIFIED DATA SHOULD BE MADE BY CONSULTING THE MOST RECENT JOINT HAZARD CLASSIFICATION SYSTEM LISTING OR OTHER APPROVED LISTING(S).

REVISIONS

REVISION NO. 1, DATED AUGUST 1998, CONSISTS OF:

ADDING ITEM BY NATIONAL STOCK NUMBER (NSN) TO "PALLET UNIT DATA" CHART.

REVISION NO. 2, DATED AUGUST 2020, CONSISTS OF CHANGES PER ECP R20K3003 (1-3):

1. UPDATING THE HAZARD CLASS AND DIVISION FOR DODIC HA06.
2. ADDING ITEM BY NATIONAL STOCK NUMBER (NSN) TO "PALLET UNIT DATA" CHART.
3. UPDATING THE HAZARD CLASS AND DIVISION FOR DODIC H812.
4. UPDATING DRAWING TO FOUR PAGE FORMAT.

GENERAL NOTES

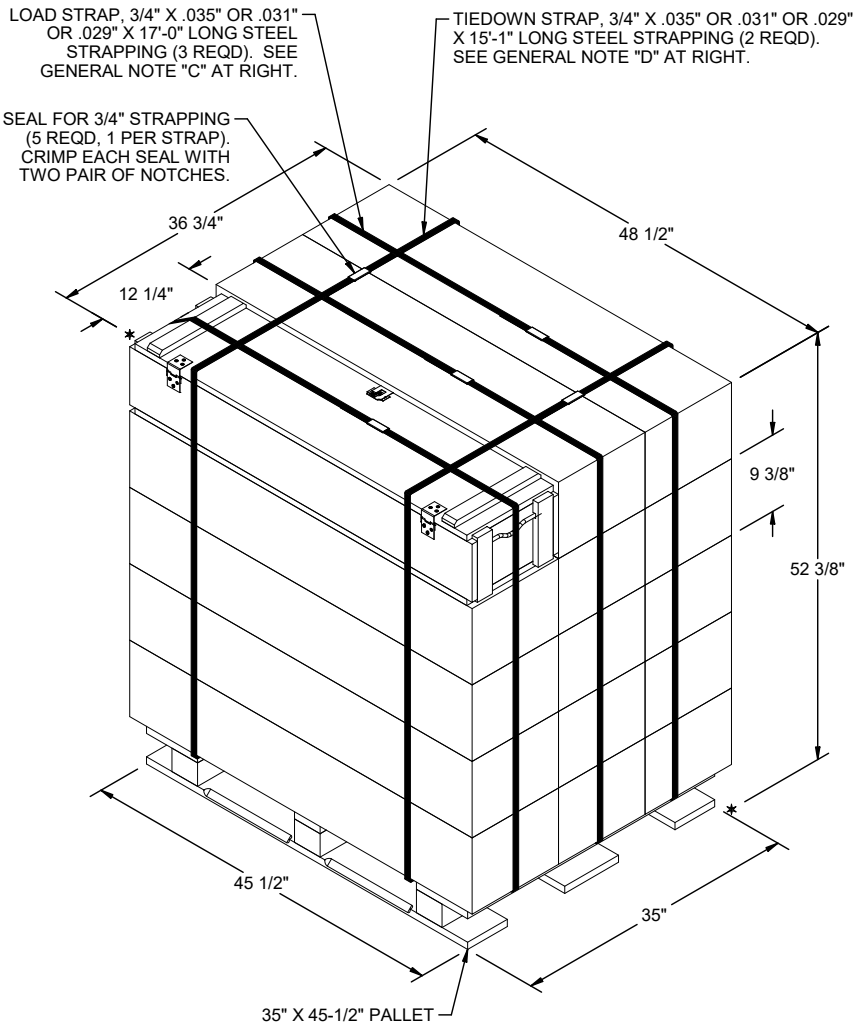

PALLET UNIT

SEE GENERAL NOTE "B" AT RIGHT.

15 BOXES OF ROCKET WARHEADS (6 PER BOX) @ 124.0 LBS	- -	1,860 LBS
DUNNAGE	- - - - -	8 LBS
PALLET	- - - - -	65 LBS
TOTAL WEIGHT		1,933 LBS (APPROX)
CUBE		54.0 CU FT (APPROX)

BILL OF MATERIAL

PALLET, 35" X 45-1/2"	- - - - -	1 REQD	- - - - -	65 LBS
STEEL STRAPPING, 3/4"	-	81.17' REQD	- - - - -	7.25 LBS
SEAL FOR 3/4" STRAPPING	- - -	5 REQD	- - - - -	NIL

- A. THIS APPENDIX CANNOT STAND ALONE BUT MUST BE USED IN CONJUNCTION WITH THE BASIC UNITIZATION PROCEDURES DRAWING 19-48-4116-20PA1002. TO PRODUCE AN APPROVED UNIT LOAD, ALL PERTINENT PROCEDURES, SPECIFICATIONS AND CRITERIA SET FORTH WITHIN THE BASIC DRAWING WILL APPLY TO THE PROCEDURES DELINEATED IN THIS APPENDIX. ANY EXCEPTIONS TO THE BASIC PROCEDURES ARE SPECIFIED IN THIS APPENDIX.
- B. DIMENSIONS, CUBE AND WEIGHT OF A PALLET UNIT WILL VARY SLIGHTLY DEPENDING UPON THE ACTUAL DIMENSIONS OF THE BOXES AND THE WEIGHT OF THE SPECIFIC ITEM BEING UNITIZED.
- C. THE LOAD STRAPS MAY BE THREADED THROUGH THE STRAP SLOTS OF A PALLET OR PRE-POSITIONED ON THE PALLET DECK PRIOR TO PLACING THE BOXES ON THE PALLET. LOAD STRAPS WILL NOT BE TENSIONED AND SEALED UNTIL THE TIEDOWN STRAPS HAVE BEEN TENSIONED AND SEALED.
- D. INSTALL EACH TIEDOWN STRAP TO PASS UNDER THE TOP DECK BOARDS OF THE PALLET AND TO BE LOCATED AS SHOWN. TIEDOWN STRAPS MUST BE TENSIONED AND SEALED PRIOR TO APPLICATION OF THE LOAD STRAPS.
- E. THE FOLLOWING AMC DRAWINGS ARE APPLICABLE FOR OUTLOADING AND STORAGE OF THE ITEMS COVERED BY THIS APPENDIX.

CARLOADING	- - - -	19-48-4115-5PA1002
TRUCKLOADING	- - - -	19-48-4117-11PA1003
STORAGE	- - - -	19-48-4118-1-2-3-4-14-22PA1002
END OPENING ISO CONTAINER	- - - -	19-48-4153-15PA1002
MILVAN	- - - -	19-48-4166-15PA1003
SIDE OPENING ISO CONTAINER	- - - -	19-48-4267-15PA1009
- F. IF ITEMS COVERED HEREIN ARE UNITIZED PRIOR TO ISSUANCE OF THIS REVISION TO THIS APPENDIX, THE BOXES NEED NOT BE REUNITIZED SOLELY TO CONFORM TO THIS REVISION.
- G. THE UNITIZATION PROCEDURES DEPICTED HEREIN MAY ALSO BE USED FOR UNITIZING ROCKET WARHEADS WHEN IDENTIFIED BY DIFFERENT NATIONAL STOCK NUMBERS (NSN) THAN WHAT IS SHOWN ON PAGE 2, PROVIDED THE BOX PACK DOES NOT VARY FROM WHAT IS DELINEATED HEREIN. THE EXPLOSIVE CLASSIFICATION OF OTHER ITEMS MAY BE DIFFERENT THAN WHAT IS SHOWN.
- H. THE STYLE 1A PALLET DELINEATED IN THE DETAIL AT LEFT NEED NOT HAVE CHAMFERS OR STRAP SLOTS AS SPECIFIED WITHIN MILITARY SPECIFICATION MIL-DTL-15011 WHEN USED FOR THE UNITIZATION OF ITEMS COVERED BY THIS APPENDIX.
- J. WHEN THE UNIT LOAD DEPICTED AT LEFT IS TO BE USED FOR UNITIZING MARINE CORPS AMMUNITION, ONE LAYER OF BOXES MUST BE OMITTED, TIEDOWN STRAP LENGTHS MUST BE DECREASED TO 13'-6", AND LOAD STRAP LENGTHS MUST BE DECREASED TO 15'-5". THIS WILL RESULT IN AN OVERALL UNIT HEIGHT OF 43", A GROSS UNIT WEIGHT OF 1,560 POUNDS, AND A UNIT CUBE OF 44.4 CUBIC FEET. ADDITIONALLY, THE UNIT MAY BE MODIFIED AS DESCRIBED WHEN BEING SHIPPED BY MILVAN OR ISO INTERMODAL FREIGHT CONTAINER, VAN TRAILER, OR BOXCAR. THE DETERMINATION TO REDUCE THE LOAD BY A LAYER FOR TRANSPORTATION WILL BE MADE BY THE RESPONSIBLE COMMAND AND WILL BE BASED UPON ECONOMICS OF TRANSPORTATION AND HANDLING.
- K. FOR DETAILS OF THE MIL-DTL-2427, TYPE II, CLASS 2 WOODEN BOX SEE ARDEC DRAWING 12977529.

TIE PIECE, 1" X 4" X BOX WIDTH (3 REQD).
NAIL TO THE LATERAL PIECES W/2-6d
NAILS AND TO THE LONGITUDINAL PIECES
W/2-6d NAILS AT EACH END.

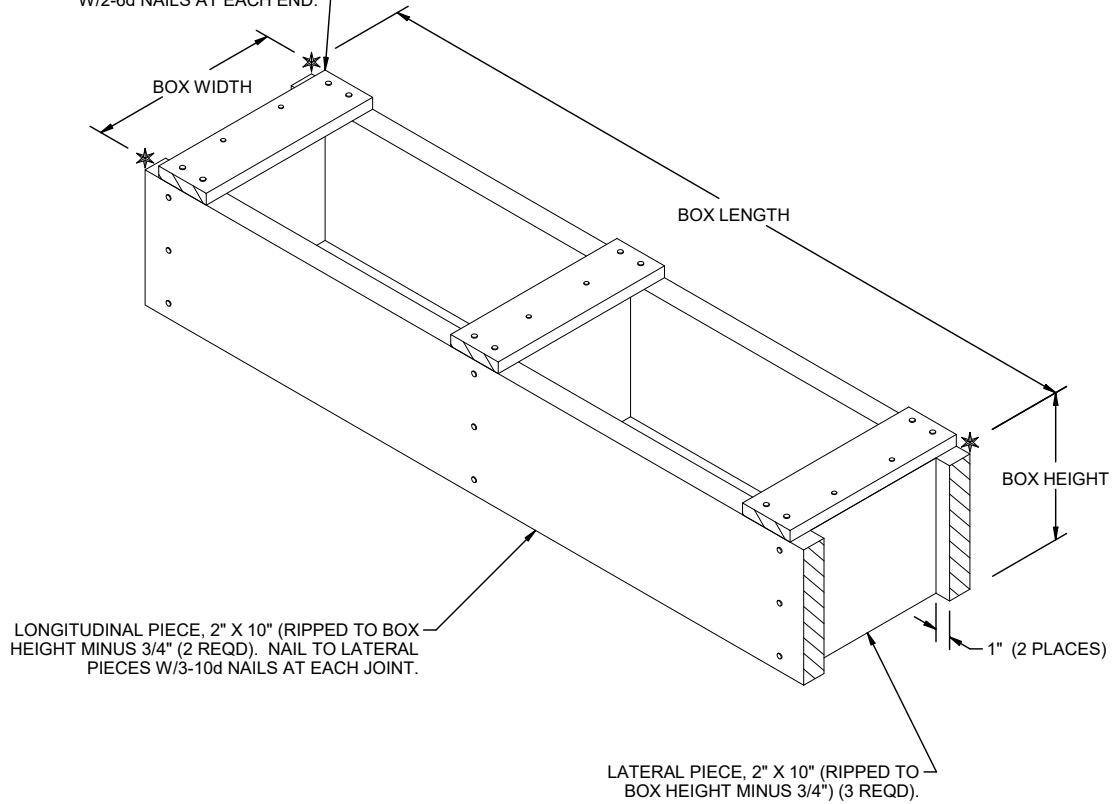

FILLER ASSEMBLY
(FOR MINUS ONE BOX)