

APPENDIX 80K

UNITIZATION PROCEDURES FOR BOXED AMMUNITION AND COMPONENTS ON 4-WAY ENTRY PALLETS

WARHEAD, 2.75 INCH ROCKET, PACKED 14 PER MK 12
MOD 0 METAL BOX, UNITIZED 20 BOXES PER 35" X 45 $\frac{1}{2}$ "
PALLET; APPROX BOX SIZE 18 $\frac{1}{4}$ " L X 9 $\frac{19}{64}$ " W X 12 $\frac{3}{4}$ " H

PALLET UNIT DATA						
ITEMS INCLUDED		HAZARD CLASSIFICATION				WEIGHT (LBS)
NSN	DODIC	DOT CLASS	CG CLASS	QD CLASS	COMP GROUP	
1340- 00-038-8176	H837	A	<u>VII</u>	1.1	D	2,271

NOTICE: THIS APPENDIX CANNOT STAND ALONE BUT MUST BE USED IN CONJUNCTION WITH THE BASIC UNITIZATION PROCEDURES DRAWING 19-48-4116-20PA1002.

REVISIONS				DRAFTSMAN <i>Dier</i>	PROJ ENG <i>WRE/HAW</i>
				CHECKER <i>WJM</i>	LOG ENGRG OFFICE <i>W & Bent</i>
				APPROVED U S ARMY ARMAMENT MATERIEL READINESS COMMAND	
				<i>W & Bent</i> DRSAR TMD <i>John L. Byrd Jr</i> DRSAR TMD APPROVED BY ORDER OF COMMANDING GENERAL U S ARMY MATERIEL DEVELOPMENT AND READINESS COMMAND (DARCOM) U S ARMY DEFENSE AMMUNITION CENTER AND SCHOOL	
				U. S. ARMY DARCOM DRAWING	
				APRIL 1982	
				CLASS	DIVISION
				19	48
				DRAWING	FILE
				4116/ 80K	20PA 1002

DO NOT SCALE

GENERAL NOTES

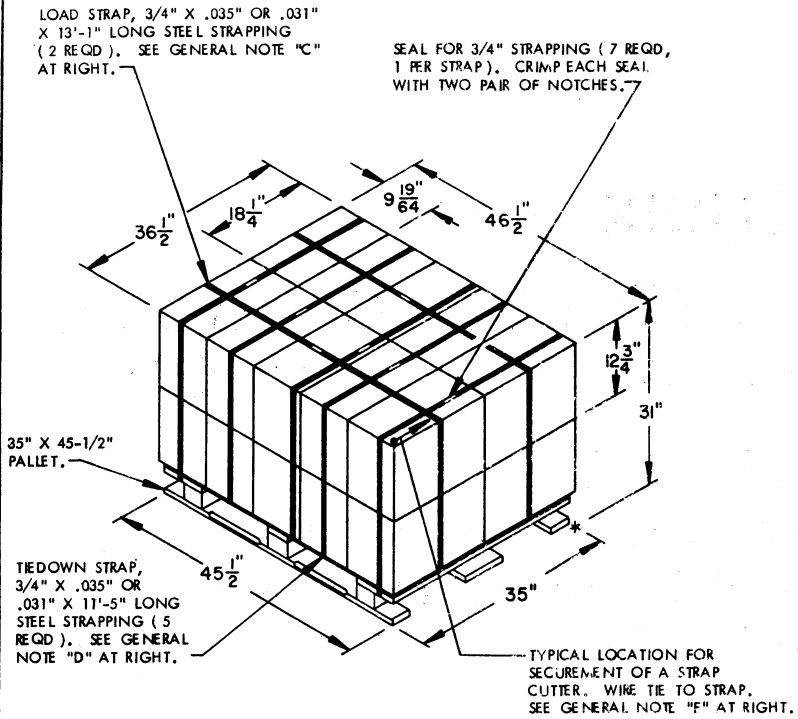

- A. THIS APPENDIX CANNOT STAND ALONE BUT MUST BE USED IN CONJUNCTION WITH THE BASIC UNITIZATION DRAWING 19-48-4116-20PA1002. TO PRODUCE AN APPROVED UNIT LOAD, ALL PERTINENT PROCEDURES, SPECIFICATIONS AND CRITERIA SET FORTH WITHIN THE BASIC DRAWING WILL APPLY TO THE PROCEDURES DELINEATED IN THIS APPENDIX. ANY EXCEPTIONS TO THE BASIC PROCEDURES ARE SPECIFIED IN THIS APPENDIX.
- B. DIMENSIONS, CUBE AND WEIGHT OF A PALLET UNIT WILL VARY SLIGHTLY DEPENDING UPON THE ACTUAL DIMENSIONS OF THE BOXES AND THE WEIGHT OF THE SPECIFIC ITEM BEING UNITIZED.
- C. THE LOAD STRAPS WILL BE THREADED THROUGH THE STRAP SLOTS OF A PALLET OR PRE-POSITIONED ON THE PALLET DECK PRIOR TO PLACING BOXES ON THE PALLET.
- D. INSTALL EACH TIEDOWN STRAP TO PASS UNDER THE DECK/STRINGER BOARDS OF THE PALLET AND TO BE LOCATED AS SHOWN. TIEDOWN STRAPS WILL NOT BE APPLIED UNTIL THE LOAD STRAPS HAVE BEEN TENSIONED AND SEALED.
- E. THE FOLLOWING DARCOM DRAWINGS ARE APPLICABLE FOR OUTLOADING AND STORAGE OF THE ITEMS COVERED BY THIS APPENDIX.
 - CARLOADING -----DRAWING 19-48-4115-5PA1002
 - TRUCK LOADING -----DRAWING 19-48-4117-11PA1003
 - STORAGE -----DRAWING 19-48-4118-1-2-3-4-14-22PA1002
- F. FOR METHOD OF SECURING A STRAP CUTTER TO THE PALLET UNIT, SEE DARCOM DRAWING 19-48-4127-20P1000.
- G. IF ITEMS COVERED HEREIN ARE UNITIZED PRIOR TO ISSUANCE OF THIS APPENDIX, THE BOXES NEED NOT BE REUNITIZED SOLELY TO CONFORM TO THIS APPENDIX.
- H. THE UNITIZATION PROCEDURES DEPICTED HEREIN MAY ALSO BE USED FOR UNITIZING WARHEADS WHEN IDENTIFIED BY DIFFERENT NATIONAL STOCK NUMBERS (NSN) THAN WHAT IS SHOWN ON THE TITLE PAGE, PROVIDED THE BOX PACK DOES NOT VARY FROM WHAT IS DELINEATED HEREIN. THE EXPLOSIVE CLASSIFICATION OF OTHER ITEMS MAY BE DIFFERENT THAN WHAT IS SHOWN.

PALLET UNIT

SEE GENERAL NOTE "B" AT RIGHT.

20 BOXES OF WARHEADS (14 PER BOX) @ 110 LBS -----	2,200 LBS (APPROX)
DUNNAGE -----	6 LBS
PALLET -----	65 LBS
TOTAL WEIGHT -----	2,271 LBS (APPROX)
CUBE -----	30.4 CU FT (APPROX)

BILL OF MATERIAL

PALLET, 35" X 45-1/2" -----	1 REQD -----	65 LBS
STEEL STRAPPING, 3/4" -----	83.25' REQD -----	5.95 LBS
SEAL FOR 3/4" STRAPPING -----	7 REQD -----	NIL

