

APPENDIX 80H

UNITIZATION PROCEDURES FOR BOXED AMMUNITION AND COMPONENTS ON 4-WAY ENTRY PALLETS

WARHEAD, 2.75 INCH, WTU-1/B, PACKED 48 PER
PLYWOOD BOX, UNITIZED 4 BOXES PER 40" X 48"
PALLET; APPROX BOX SIZE 26" L X 20" W X 22" H

PALLET UNIT DATA						
ITEMS INCLUDED		HAZARD CLASSIFICATION				WEIGHT (LBS)
NSN	DODIC	DOT CLASS	CG CLASS	QD CLASS	COMP GROUP	
1340- 01-014-5421	H663	—	—	—	—	1,952

NOTICE: THIS APPENDIX CANNOT STAND ALONE BUT MUST
BE USED IN CONJUNCTION WITH THE BASIC UNITIZATION
PROCEDURES DRAWING 19-48-4116-20PA1002.

REVISIONS				DRAFTSMAN <i>SAR</i>	PROJECT <i>WREBLWS</i>
				CHECKER <i>CEB</i>	LOG ENGRG OFFICE <i>W. B. D. M.</i>
APPROVED, U. S. ARMY ARMAMENT MATERIEL READINESS COMMAND					
				<i>W. H. ...</i>	<i>...</i>
				DRSAR - LEP	DRSAR - TMD
APPROVED BY ORDER OF COMMANDING GENERAL, U. S. ARMY MATERIEL DEVELOPMENT AND READINESS COMMAND (DARCOM)					
<i>John A. ...</i> U. S. ARMY DEFENSE AMMUNITION CENTER AND SCHOOL					
U. S. ARMY DARCOM DRAWING					
APRIL 1982					
CLASS	DIVISION	DRAWING	FILE		
19	48	4116/ 80H	20PA 1002		

DO NOT SCALE

PROJECT FSA 146/80H-75

GENERAL NOTES

- A. THIS APPENDIX CANNOT STAND ALONE BUT MUST BE USED IN CONJUNCTION WITH THE BASIC UNITIZATION PROCEDURES DRAWING 19-48-4116-20PA1002. TO PRODUCE AN APPROVED UNIT LOAD, ALL PERTINENT PROCEDURES, SPECIFICATIONS AND CRITERIA SET FORTH WITHIN THE BASIC DRAWING WILL APPLY TO THE PROCEDURES DELINEATED IN THIS APPENDIX. ANY EXCEPTIONS TO THE BASIC PROCEDURES ARE SPECIFIED IN THIS APPENDIX.
- B. DIMENSIONS, CUBE AND WEIGHT OF A PALLET UNIT WILL VARY SLIGHTLY DEPENDING UPON THE ACTUAL DIMENSIONS OF THE BOXES AND THE WEIGHT OF THE SPECIFIC ITEM BEING UNITIZED.
- C. THE LOAD STRAPS WILL BE THREADED THROUGH THE STRAP SLOTS OF A PALLET PRIOR TO PLACING BOXES ON THE PALLET. LOAD STRAPS MUST BE TENSIONED AND SEALED PRIOR TO APPLICATION OF TIEDOWN STRAPS.
- D. INSTALL EACH TIEDOWN STRAP TO PASS UNDER THE TOP DECK BOARDS OF THE PALLET AND TO BE LOCATED AS SHOWN. TIE-DOWN STRAPS WILL NOT BE APPLIED UNTIL THE LOAD STRAPS HAVE BEEN TENSIONED AND SEALED.
- E. THE FOLLOWING DARCOM DRAWINGS ARE APPLICABLE FOR UNLOADING AND STORAGE OF THE ITEMS COVERED BY THIS APPENDIX.
 CARLOADING-----DRAWING 19-48-4115-SPA1002
 TRUCKLOADING-----DRAWING 19-48-4117-11PA1003
 STORAGE-----DRAWING 19-48-4118-1-2-3-4-14-22PA1002
- F. FOR METHOD OF SECURING A STRAP CUTTER TO THE PALLET UNIT, SEE DARCOM DRAWING 19-48-4127-20P1000.
- G. IF ITEMS COVERED HEREIN ARE UNITIZED PRIOR TO ISSUANCE OF THIS APPENDIX, THE BOXES NEED NOT BE REUNITIZED SOLELY TO CONFORM TO THIS APPENDIX.
- H. THE UNITIZATION PROCEDURES DEPICTED HEREIN MAY ALSO BE USED FOR UNITIZING 2.75 ROCKET WARHEADS WHEN IDENTIFIED BY DIFFERENT NATIONAL STOCK NUMBERS (NSN) THAN WHAT IS SHOWN ON THE TITLE PAGE, PROVIDED THE BOX PACK DOES NOT VARY FROM WHAT IS DELINEATED HEREIN. THE EXPLOSIVE CLASSIFICATION OF OTHER ITEMS MAY BE DIFFERENT THAN WHAT IS SHOWN.
- J. IF THERE IS A NEED TO USE FILLER ASSEMBLIES AND AT LEAST TWO PALLET UNITS ARE BEING CONSTRUCTED, NOT MORE THAN TWO FILLERS WILL BE INSTALLED IN ANY ONE PALLET UNIT. ADDITIONAL FILLERS CAN BE PUT IN A SECOND PALLET UNIT AS REQUIRED WHEN THE QUANTITY OF TWO FILLERS IN THE FIRST REDUCED PALLET UNIT IS INSUFFICIENT TO SATISFY THE TOTAL REDUCTION NEEDED. USING TWO PALLET UNITS TO SATISFY THE PALLETIZATION CRITERIA APPLICABLE TO LESS-THAN-FULL PALLET UNITS IS AN EXCEPTION TO THE BASIC PROCEDURES. HOWEVER, THE EXCEPTION IS NECESSARY FOR THE AMMUNITION PACK COVERED BY THIS APPENDIX, TO MOST EFFECTIVELY GET AN ACCEPTABLE, COMPACT AND SOUND PALLET UNIT.

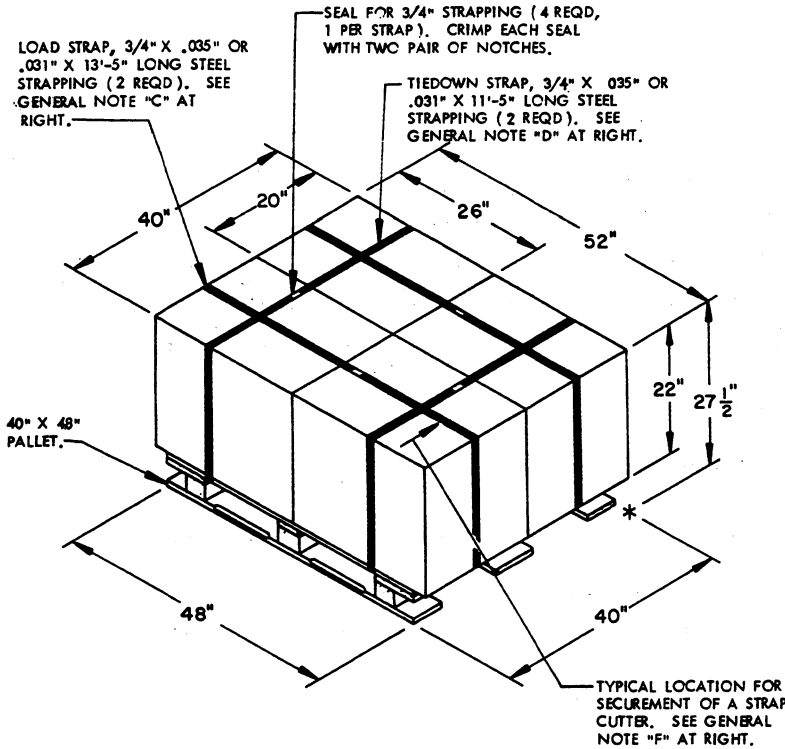

PALLET UNIT

SEE GENERAL NOTE "B" AT RIGHT.

4 BOXES OF WARHEADS (48 PER BOX) @ 467 LBS-----	1,868 LBS (APPROX)
DUNNAGE-----	4 LBS
PALLET-----	80 LBS
TOTAL WEIGHT-----	1,952 LBS (APPROX)
CUBE-----	33.1 CU FT (APPROX)

BILL OF MATERIAL

PALLET, 40" X 48"-----	1 REQD-----	80 LBS
STEEL STRAPPING, 3/4"-----	49.67' REQD-----	3.55 LBS
SEAL FOR 3/4" STRAPPING-----	4 REQD-----	NIL

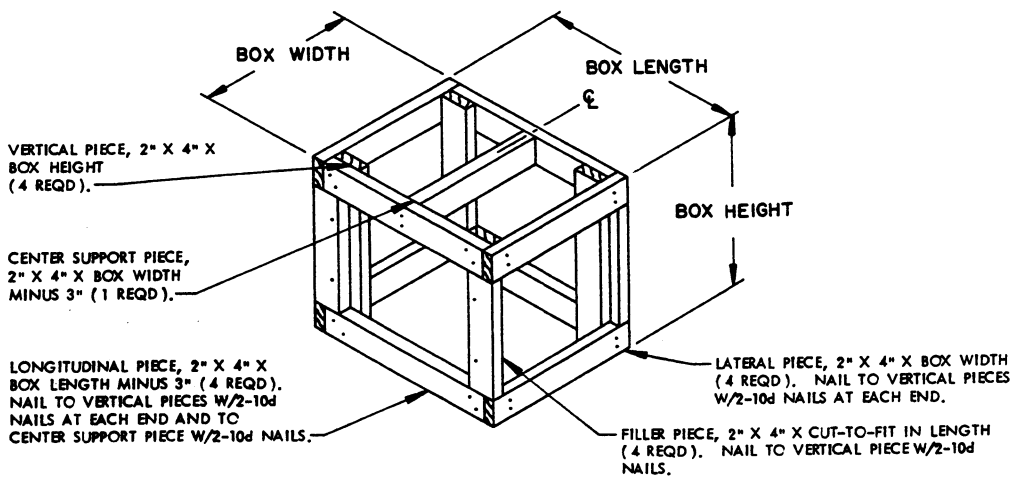

FILLER ASSEMBLY

(FOR MINUS ONE BOX)