

# APPENDIX 80E

## UNITIZATION PROCEDURES FOR BOXED AMMUNITION AND COMPONENTS ON 4-WAY ENTRY PALLETS

WARHEAD, 2.75 INCH, PACKED 4 PER WOODEN BOX,  
UNITIZED 16 BOXES PER 35" X 45½" PALLET; APPROX  
BOX SIZE 36¾" L X 12⅛" W X 7¾" H

PALLET UNIT DATA						
ITEMS INCLUDED		HAZARD CLASSIFICATION				WEIGHT (LBS)
NSN	DODIC	DOT CLASS	CG CLASS	QD CLASS	COMP GROUP	
1340-						
00-038-8186	H836	A	VII	1.1	D	1,831
00-309-5097	H836	A	VII	1.1	D	1,831
00-038-8176	H837	A	VII	1.1	D	1,895
00-309-5098	H837	A	VII	1.1	D	1,895

**NOTICE:** THIS APPENDIX CANNOT STAND ALONE BUT MUST BE USED IN CONJUNCTION WITH THE BASIC UNITIZATION PROCEDURES DRAWING 19-48-4116-20PA1002.

REVISIONS				DRAFTSMAN NCC/sib	PROJ ENG WRF/WRF
				APPROVED LOG ENGRG OFFICE W & Ernst	LOG ENGRG OFFICE W & Ernst
				APPROVED U.S. ARMY ARMAMENT MATERIEL READINESS COMMAND	
				DRSAR - LEP      DRSAR - TMD	
				APPROVED BY ORDER OF COMMANDING GENERAL, U.S. ARMY MATERIEL DEVELOPMENT AND READINESS COMMAND (DARCOM) U.S. ARMY DEFENSE AMMUNITION CENTER AND SCHOOL	
				U.S. ARMY DARCOM DRAWING	
				DECEMBER 1982	
				CLASS	DIVISION
				DRAWING	FILE
				19	48
				4116/ 80E	20PA 1002

DO NOT SCALE

TIEDOWN STRAP, 3/4" X .035" OR .031" X 12'-5" STRAPPING (4 REQD). SEE GENERAL NOTE "D" AT RIGHT.

SEAL FOR 3/4" STRAPPING (6 REQD, 1 PER STRAP). CRIMP EACH SEAL WITH TWO PAIR OF NOTCHES.

LOAD STRAP, 3/4" X .035" OR .031" X 14'-4" LONG STEEL STRAPPING (2 REQD). SEE GENERAL NOTE "C" AT RIGHT.

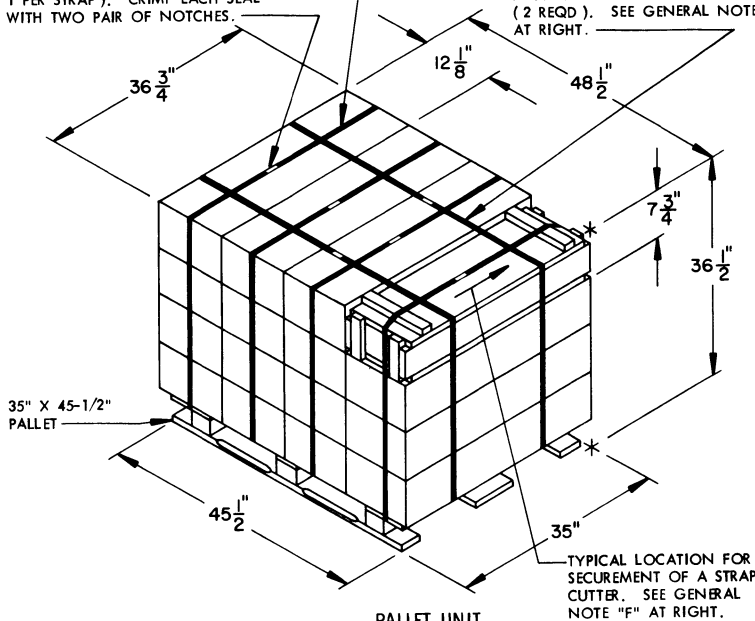

**PALLET UNIT**

SEE GENERAL NOTE "B" AT RIGHT.

16 BOXES OF WARHEADS (4 PER BOX) @ 114 LBS	-----	1,824 LBS (APPROX)
DUNNAGE	-----	6 LBS
PALLET	-----	65 LBS
<b>TOTAL WEIGHT</b>	-----	<b>1,895 LBS (APPROX)</b>
<b>CUBE</b>	-----	<b>37.6 CU FT (APPROX)</b>

**BILL OF MATERIAL**

PALLET, 35" X 45-1/2"	-----	1 REQD	-----	65 LBS
STEEL STRAPPING, 3/4"	-----	78.33 REQD	-----	5.60 LBS
SEAL FOR 3/4" STRAPPING	-----	6 REQD	-----	NIL

**GENERAL NOTES**

- A. THIS APPENDIX CANNOT STAND ALONE BUT MUST BE USED IN CONJUNCTION WITH THE BASIC UNITIZATION PROCEDURES DRAWING 19-48-4116-20PA1002. TO PRODUCE AN APPROVED UNIT LOAD, ALL PERTINENT PROCEDURES, SPECIFICATIONS AND CRITERIA SET FORTH WITHIN THE BASIC DRAWING WILL APPLY TO THE PROCEDURES DELINEATED IN THIS APPENDIX. ANY EXCEPTIONS TO THE BASIC PROCEDURES ARE SPECIFIED IN THIS APPENDIX.
- B. DIMENSIONS, CUBE AND WEIGHT OF A PALLET UNIT WILL VARY SLIGHTLY DEPENDING UPON THE ACTUAL DIMENSIONS OF THE BOXES AND THE WEIGHT OF THE SPECIFIC ITEM BEING UNITIZED.
- C. THE LOAD STRAPS MAY BE THREADED THROUGH THE STRAP SLOTS OF A PALLET OR PRE-POSITIONED ON THE PALLET DECK PRIOR TO PLACING BOXES ON THE PALLET. LOAD STRAPS MUST BE TENSIONED AND SEALED PRIOR TO APPLICATION OF TIEDOWN STRAPS.
- D. INSTALL EACH TIEDOWN STRAP TO PASS UNDER THE DECK/STRINGER BOARDS OF THE PALLET AND TO BE LOCATED AS SHOWN. TIEDOWN STRAPS WILL NOT BE APPLIED UNTIL THE LOAD STRAPS HAVE BEEN TENSIONED AND SEALED.
- E. THE FOLLOWING DARCOM DRAWINGS ARE APPLICABLE FOR OUTLOADING AND STORAGE OF THE ITEMS COVERED BY THIS APPENDIX.
  - CARLOADING ----- DRAWING 19-48-4115-5PA1002
  - TRUCKLOADING --- DRAWING 19-48-4117-11PA1003
  - STORAGE ----- DRAWING 19-48-4118-1-2-3-4-14-22PA1002
- F. FOR METHOD OF SECURING A STRAP CUTTER TO THE PALLET UNIT, SEE DARCOM DRAWING 19-48-4127-20P1000.
- G. IF ITEMS COVERED HEREIN ARE UNITIZED PRIOR TO ISSUANCE OF THIS APPENDIX, THE BOXES NEED NOT BE REUNITIZED SOLELY TO CONFORM TO THIS APPENDIX.
- H. THE UNITIZATION PROCEDURES DEPICTED HEREIN MAY ALSO BE USED FOR UNITIZING 2.75 INCH WARHEADS WHEN IDENTIFIED BY DIFFERENT NATIONAL STOCK NUMBERS (NSN) THAN WHAT IS SHOWN ON THE TITLE PAGE, PROVIDED THE BOX PACK DOES NOT VARY FROM WHAT IS DELINEATED HEREIN. THE EXPLOSIVE CLASSIFICATION OF OTHER ITEMS MAY BE DIFFERENT THAN WHAT IS SHOWN.

TIE PIECE, 1" X 4" X BOX WIDTH (3 REQD). NAIL TO LONGITUDINAL PIECES W/2-6d NAILS AT EACH END AND TO LATERAL PIECE W/2-6d NAILS.

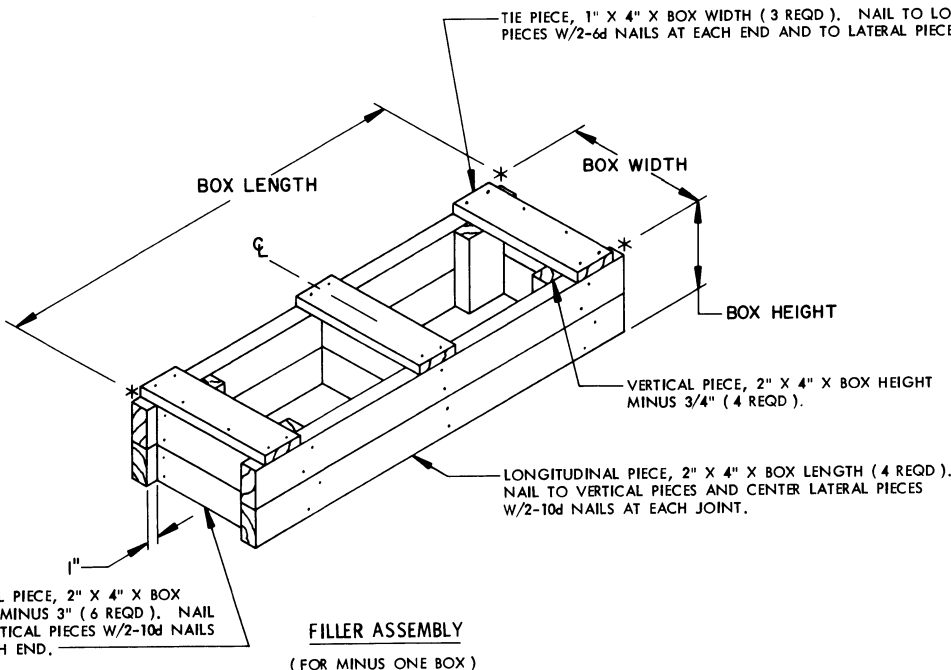

**FILLER ASSEMBLY**

(FOR MINUS ONE BOX)