

APPENDIX 80C

UNITIZATION PROCEDURES FOR BOXED AMMUNITION AND COMPONENTS ON 4-WAY ENTRY PALLETS

ROCKET, 2.75 INCH, WITH WARHEAD, PACKED 3 OR 4
PER WOODEN BOX, UNITIZED 15 BOXES PER
40" X 48" PALLET; APPROX BOX SIZE $62\frac{13}{16}$ " L
X $8\frac{11}{16}$ " W X $9\frac{1}{2}$ " H

PALLET UNIT DATA						
ITEMS INCLUDED		HAZARD CLASSIFICATION				WEIGHT
NSN	DOD IC	DOT CLASS	CG CLASS	QD CLASS	COMP GROUP	(LBS)
1340-						
00-003-1102	H161	A	IV	1.1	E	1,988
00-143-7097	H828	B	II-B	(12)1.2	C	1,988
00-143-7099	H489	A	IV	1.1	E	1,688
00-143-7100	H489	A	IV	1.1	E	1,988
00-159-3308	H828	B	II-B	(12)1.2	C	1,988
00-191-3306	H490	A	IV	1.1	E	1,988
00-223-7219	H489	A	IV	1.1	E	1,988
00-223-7224	H459	B	II-B	(12)1.2	C	1,988
00-406-7327	H519	A	II-D	(12)1.2	H	1,988
00-689-4075	H826	A	IV	1.1	E	1,988
00-912-4548	H519	A	II-D	(12)1.2	H	1,988
00-935-9250	H470	A	IV	1.1	E	1,988
00-935-9257	H490	A	IV	1.1	E	1,688

●NOTE: THE PROCEDURES CONTAINED WITHIN THIS DRAWING SUPERSEDE GUIDANCE CONTAINED IN DARCOM DRAWING 19-48-4015-12P1000 PERTAINING TO THE VERTICAL PALLETIZATION OF 2.75" ROCKETS WITH WHITE PHOSPHORUS OR PLASTICIZED WHITE PHOSPHORUS FILLED WARHEADS.

NOTICE: THIS APPENDIX CANNOT STAND ALONE BUT MUST BE USED IN CONJUNCTION WITH THE BASIC UNITIZATION PROCEDURES DRAWING 19-48-4116-20PA1002.

REVISION

REVISION NO. 1, DATED JULY 1981, CONSISTS OF :

1. ADDING NATIONAL STOCK NUMBERS TO THE "PALLET UNIT DATA" CHART.
2. ADDING A NOTE REGARDING THE PALLETIZATION OF ROCKETS HAVING WHITE PHOSPHORUS OR PLASTICIZED WHITE PHOSPHORUS FILLED WARHEADS.
3. UPDATING STORAGE DRAWING NUMBER.

DO NOT SCALE

REVISIONS				DRAFTSMAN g m h / m b k	PROJ ENG R B / h e u s
1	JUL 81	<i>WFE</i>	<i>M Baiman</i>	RSH	<i>John Bork</i>
				DARCOM-LEP	DARCOM-TMD
APPROVED, U. S. ARMY ARMAMENT MATERIEL READINESS COMMAND					
				<i>W Benton</i>	<i>Devel</i>
				DARCOM-MAD	DARCOM-TMD
APPROVED BY ORDER OF COMMANDING GENERAL, U. S. ARMY MATERIEL DEVELOPMENT AND READINESS COMMAND (DARCOM)					
				<i>John B. Fant</i>	
U. S. ARMY DEFENSE AMMUNITION CENTER AND SCHOOL					
U. S. ARMY DARCOM DRAWING					
JULY 1980					
CLASS	DIVISION	DRAWING	FILE		
19	48	4116/80C	20PA 1002		

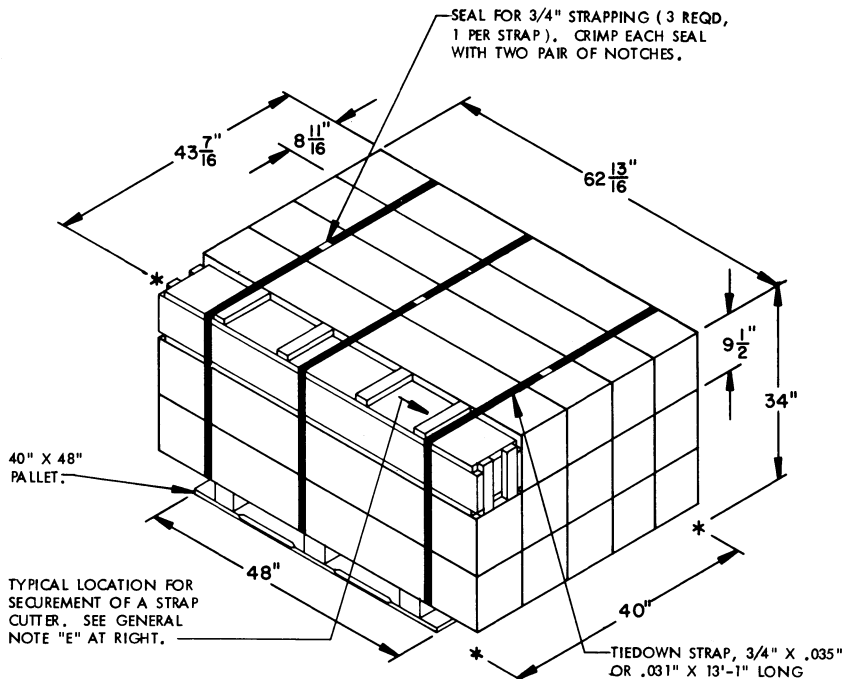

PALLET UNIT

SEE GENERAL NOTE "B" AT RIGHT.

15 BOXES OF 2.75 INCH ROCKETS @ 127 LBS -----	1,905 LBS (APPROX)
DUNNAGE -----	3 LBS
PALLET -----	80 LBS
TOTAL WEIGHT -----	1,988 LBS (APPROX)
CUBE -----	53.7 CU FT (APPROX)

GENERAL NOTES

- A. THIS APPENDIX CANNOT STAND ALONE BUT MUST BE USED IN CONJUNCTION WITH THE BASIC UNITIZATION PROCEDURES DRAWING 19-48-4116-20PA1002. TO PRODUCE AN APPROVED UNIT LOAD, ALL PERTINENT PROCEDURES, SPECIFICATIONS AND CRITERIA SET FORTH WITHIN THE BASIC DRAWING WILL APPLY TO THE PROCEDURES DELINEATED IN THIS APPENDIX. ANY EXCEPTIONS TO THE BASIC PROCEDURES ARE SPECIFIED IN THIS APPENDIX.
- B. DIMENSIONS, CUBE AND WEIGHT OF A PALLET UNIT WILL VARY SLIGHTLY DEPENDING UPON THE ACTUAL DIMENSIONS OF THE BOXES AND THE WEIGHT OF THE SPECIFIC ITEM BEING UNITIZED.
- C. INSTALL EACH TIEDOWN STRAP TO PASS UNDER THE DECK/ STRINGER BOARDS OF THE PALLET AND TO BE LOCATED AS SHOWN.
- D. THE FOLLOWING DARCOM DRAWINGS ARE APPLICABLE FOR OUTLOADING AND STORAGE OF THE ITEMS COVERED BY THIS APPENDIX.

CARLOADING -----	DRAWING 19-48-4115-5PA1002
TRUCKLOADING -----	DRAWING 19-48-4117-11PA1003
STORAGE -----	DRAWING 19-48-4118-1-2-3-4-14-22PA-1002
- E. FOR METHOD OF SECURING A STRAP CUTTER TO THE PALLET UNIT, SEE DARCOM DRAWING 19-48-4127-20P1000.
- F. IF ITEMS COVERED HEREIN ARE UNITIZED PRIOR TO ISSUANCE OF THIS APPENDIX, THE BOXES NEED NOT BE REUNITIZED SOLELY TO CONFORM TO THIS APPENDIX.
- G. THE UNITIZATION PROCEDURES DEPICTED HEREIN MAY ALSO BE USED FOR UNITIZING 2.75 INCH ROCKETS WHEN IDENTIFIED BY DIFFERENT NATIONAL STOCK NUMBERS (NSN) THAN WHAT IS SHOWN ON THE TITLE PAGE, PROVIDED THE BOX PACK DOES NOT VARY FROM WHAT IS DELINEATED HEREIN. THE EXPLOSIVE CLASSIFICATION OF OTHER ITEMS MAY BE DIFFERENT THAN WHAT IS SHOWN.

BILL OF MATERIAL

PALLET, 40" X 48" -----	1 REQD -----	80 LBS
STEEL STRAPPING, 3/4" -----	39.25' REQD -----	2,80 LBS
SEAL FOR 3/4" STRAPPING -----	3 REQD -----	NIL

TIE PIECE, 1" X 4" X BOX WIDTH (2 REQD). NAIL TO LATERAL PIECES W/3-6d NAILS. NAIL TO LONGITUDINAL PIECES W/1-6d NAIL AT EACH END AND TO END SUPPORT PIECE W/1-6d NAIL.

END SUPPORT PIECE, 2" X 10" (RIPPED TO BOX HEIGHT MINUS 3/4") X BOX WIDTH MINUS 3" (2 REQD).

CENTER TIE PIECE, 1" X 4" X BOX WIDTH (1 REQD). NAIL TO LONGITUDINAL PIECES W/2-6d NAILS AT EACH END AND TO CENTER SUPPORT PIECE W/1-6d NAIL.

CENTER SUPPORT PIECE, 2" X 10" (RIPPED TO BOX HEIGHT MINUS 3/4") X BOX WIDTH MINUS 3" (1 REQD).

LONGITUDINAL PIECE, 2" X 10" (RIPPED TO BOX HEIGHT MINUS 3/4") X BOX LENGTH MINUS 3" (2 REQD). NAIL TO CENTER SUPPORT PIECE W/3-10d NAILS.

LATERAL PIECE, 2" X 10" (RIPPED TO BOX HEIGHT MINUS 3/4") X BOX WIDTH (2 REQD). NAIL TO LONGITUDINAL PIECES W/3-10d NAILS AT EACH END AND TO END SUPPORT PIECE W/3-10d NAILS.

FILLER ASSEMBLY

(FOR MINUS ONE BOX)