



APPENDIX 6D

UNITIZATION PROCEDURES FOR BOXED AMMUNITION AND COMPONENTS ON 4-WAY ENTRY PALLETS

CARTRIDGE, CALIBER .22, PACKED 5,000 PER WOODEN
BOX, UNITIZED 75 BOXES PER 40" X 48" PALLET;
APPROX BOX SIZE 16 $\frac{7}{8}$ " L X 8 $\frac{3}{8}$ " W X 7 $\frac{1}{2}$ " H

PALLET UNIT DATA						
ITEMS INCLUDED		HAZARD CLASSIFICATION				WEIGHT (LBS)
NSN	DODIC	DOT CLASS	CG CLASS	QD CLASS	COMP GROUP	
1305- 01-120-4105	A090	C	I	1.4	S	3,767

NOTICE: THIS APPENDIX CANNOT STAND ALONE BUT MUST BE USED IN CONJUNCTION WITH THE BASIC UNITIZATION PROCEDURES DRAWING 19-48-4116-20PA1002.

REVISIONS				DRAFTSMAN KLC/pt	PROJ ENG WRF/WRF
				CHECKER WRF	LOG ENGRG OFFICE WRF
APPROVED, U. S. ARMY ARMAMENT MATERIEL READINESS COMMAND Y. E.					
<div style="display: flex; justify-content: space-between;"> <div style="text-align: center;">  <small>DRSAR - LEF</small> </div> <div style="text-align: center;">  <small>DRSAR - TMD</small> </div> </div>					
APPROVED BY ORDER OF COMMANDING GENERAL, U. S. ARMY MATERIEL DEVELOPMENT AND READINESS COMMAND (DARCOM)  <small>U. S. ARMY DEFENSE AMMUNITION CENTER AND SCHOOL</small>					
U. S. ARMY DARCOM DRAWING					
DECEMBER 1982					
				CLASS	DIVISION
				DRAWING	FILE
				19	48
				4116/ 6D	20PA 1002

DO NOT SCALE

TIEDOWN STRAP, 3/4" X .035" OR .031" X 14'-4" LONG STEEL STRAPPING (6 REQD). SEE GENERAL NOTE "D" AT RIGHT.

LOAD STRAP, 3/4" X .035" OR .031" X 15'-10" LONG STEEL STRAPPING (5 REQD). SEE GENERAL NOTE "C" AT RIGHT.

GENERAL NOTES

- A. THIS APPENDIX CANNOT STAND ALONE BUT MUST BE USED IN CONJUNCTION WITH THE BASIC UNITIZATION PROCEDURES DRAWING 19-48-4116-20PA1002. TO PRODUCE AN APPROVED UNIT LOAD, ALL PERTINENT PROCEDURES, SPECIFICATIONS AND CRITERIA SET FORTH WITHIN THE BASIC DRAWING WILL APPLY TO THE PROCEDURES DELINEATED IN THIS APPENDIX.
- B. DIMENSIONS, CUBE AND WEIGHT OF A PALLET UNIT WILL VARY SLIGHTLY DEPENDING UPON THE ACTUAL DIMENSIONS OF THE BOXES AND THE WEIGHT OF THE SPECIFIC ITEM BEING UNITIZED.
- C. THE LOAD STRAPS MUST BE PRE-POSITIONED ON THE PALLET DECK PRIOR TO PLACING BOXES ON THE PALLET. LOAD STRAPS MUST NOT BE TENSIONED AND SEALED UNTIL TIEDOWN STRAPS HAVE BEEN TENSIONED AND SEALED.
- D. INSTALL EACH TIEDOWN STRAP TO PASS UNDER THE DECK/ STRINGER BOARDS OF THE PALLET AND TO BE LOCATED AS SHOWN.
- E. THE FOLLOWING DARCOM DRAWINGS ARE APPLICABLE FOR OUTLOADING AND STORAGE OF THE ITEMS COVERED BY THIS APPENDIX.
 CARLOADING-----DRAWING 19-48-4115-5PA1002
 TRUCKLOADING-----DRAWING 19-48-4117-11PA1003
 STORAGE-----DRAWING 19-48-4118-1-2-3-4-14-22PA-1002
- F. FOR METHOD OF SECURING A STRAP CUTTER TO THE PALLET UNIT, SEE DARCOM DRAWING 19-48-4127-20P1000.
- G. IF ITEMS COVERED HEREIN ARE UNITIZED PRIOR TO ISSUANCE OF THIS APPENDIX, THE BOXES NEED NOT BE REUNITIZED SOLELY TO CONFORM TO THIS APPENDIX.
- H. THE UNITIZATION PROCEDURES DEPICTED HEREIN MAY ALSO BE USED FOR UNITIZING .22 CALIBER CARTRIDGES WHEN IDENTIFIED BY DIFFERENT NATIONAL STOCK NUMBERS (NSN) THAN WHAT IS SHOWN ON THE TITLE PAGE, PROVIDED THE BOX PACK DOES NOT VARY FROM WHAT IS DELINEATED HEREIN. THE EXPLOSIVE CLASSIFICATION OF OTHER ITEMS MAY BE DIFFERENT THAN WHAT IS SHOWN.

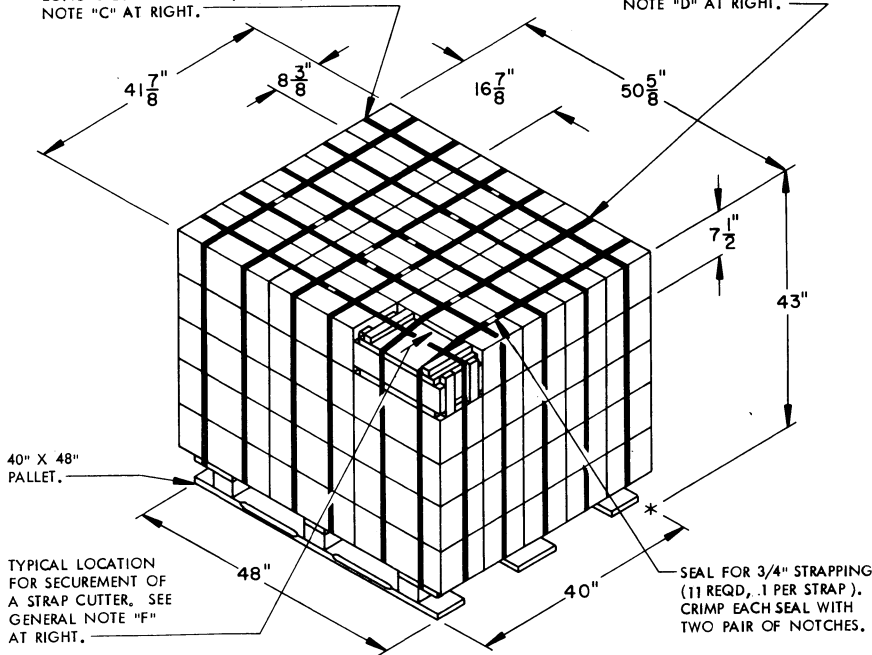

PALLET UNIT

SEE GENERAL NOTE "B" AT RIGHT.

75 BOXES OF .22 CAL CTGS (5,000 PER BOX) @ 49 LBS-----	3,675 LBS (APPROX)
DUNNAGE-----	12 LBS
PALLET-----	80 LBS
TOTAL WEIGHT-----	3,767 LBS (APPROX)
CUBE-----	52.8 CU FT (APPROX)

BILL OF MATERIAL

PALLET, 40" X 48"-----	1 REQD-----	80 LBS
STEEL STRAPPING, 3/4"-----	165.16' REQD-----	11.80 LBS
SEAL FOR 3/4" STRAPPING-----	11 REQD-----	NIL

TIE PIECE, 1" X 4" X BOX WIDTH (2 REQD), NAIL TO LONGITUDINAL PIECES W/2-6d NAILS AT EACH END AND TO LATERAL PIECE W/1-6d NAIL.

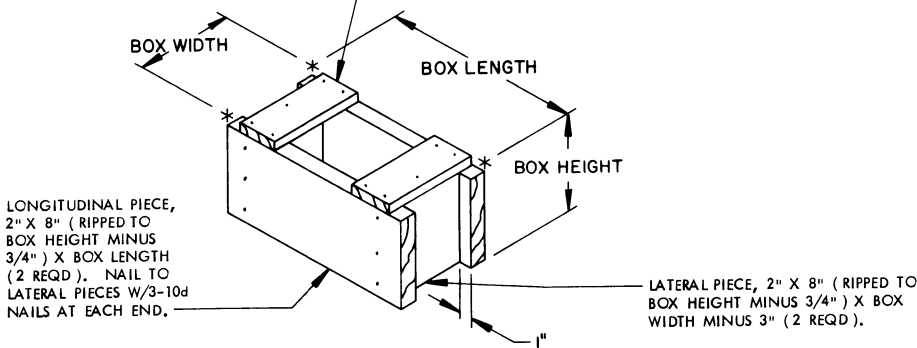

FILLER ASSEMBLY

(FOR MINUS ONE BOX)