

APPENDIX 68D

UNITIZATION PROCEDURES FOR BOXED AMMUNITION AND COMPONENTS ON 4-WAY ENTRY PALLETS

CARTRIDGE, .30 CALIBER, GRENADE, PACKED 1,600 PER
WOODEN BOX, UNITIZED 24 BOXES PER 35" X 45 $\frac{1}{2}$ "
PALLET; APPROX BOX SIZE 23 $\frac{7}{8}$ " L X 9 $\frac{1}{2}$ " W X 9 $\frac{3}{4}$ " H

| PALLET UNIT DATA | | | | | | |
|----------------------|-------|-----------------------|-------------|-------------|---------------|-----------------|
| ITEMS INCLUDED | | HAZARD CLASSIFICATION | | | | WEIGHT (LBS) |
| NSN | DODIC | DOT CLASS | CG CLASS | QD CLASS | COMP GROUP | |
| 1330- 00-028-5879 | G837 | C | I | 1.4 | S | 959 |

NOTICE: THIS APPENDIX CANNOT STAND ALONE BUT MUST
BE USED IN CONJUNCTION WITH THE BASIC UNITIZATION
PROCEDURES DRAWING 19-48-4116-20PA1002.

| REVISIONS | | | | DRAFTSMAN | PROJ ENG |
|------------------------------------------------------------------------------------------------------------|----------|----------------|--------------|------------------|------------------|
| | | | | <i>Dine</i> / pt | <i>WRF/llw</i> |
| | | | | CHECKER | LOG ENGBD OFFICE |
| | | | | <i>GRG</i> | <i>llw/llw</i> |
| APPROVED, U. S. ARMY ARMAMENT MATERIEL READINESS COMMAND | | | | | |
| <i>Dine</i> | | <i>WRF/llw</i> | | | |
| DRSAR - LEP | | DRSAR - TMD | | | |
| APPROVED BY ORDER OF COMMANDING GENERAL, U. S. ARMY MATERIEL DEVELOPMENT AND READINESS COMMAND (DARCOM) | | | | | |
| <i>John A. Spald</i> | | | | | |
| U. S. ARMY DEFENSE AMMUNITION CENTER AND SCHOOL | | | | | |
| U. S. ARMY DARCOM DRAWING | | | | | |
| FEBRUARY 1983 | | | | | |
| CLASS | DIVISION | DRAWING | FILE | | |
| 19 | 48 | 4116/ 68D | 20PA 1002 | | |

DO NOT SCALE

GENERAL NOTES

- A. THIS APPENDIX CANNOT STAND ALONE BUT MUST BE USED IN CONJUNCTION WITH THE BASIC UNITIZATION PROCEDURES DRAWING 19-48-4116-20PA1002. TO PRODUCE AN APPROVED UNIT LOAD, ALL PERTINENT PROCEDURES, SPECIFICATIONS AND CRITERIA SET FORTH WITHIN THE BASIC DRAWING WILL APPLY TO THE PROCEDURES DELINEATED IN THIS APPENDIX. ANY EXCEPTIONS TO THE BASIC PROCEDURES ARE SPECIFIED IN THIS APPENDIX.
- B. DIMENSIONS, CUBE AND WEIGHT OF A PALLET UNIT WILL VARY SLIGHTLY DEPENDING UPON THE ACTUAL DIMENSIONS OF THE BOXES AND THE WEIGHT OF THE SPECIFIC ITEM BEING UNITIZED.
- C. INSTALL EACH HORIZONTAL STRAP TO ENCIRCLE A LAYER OF BOXES AS SHOWN. HORIZONTAL STRAPS MUST BE TENSIONED AND SEALED PRIOR TO APPLICATION OF TIEDOWN STRAPS.
- D. INSTALL EACH TIEDOWN STRAP TO PASS UNDER THE TOP DECK BOARDS OF THE PALLET AND TO BE LOCATED AS SHOWN. TIEDOWN STRAPS WILL NOT BE APPLIED UNTIL THE HORIZONTAL STRAPS HAVE BEEN TENSIONED AND SEALED.
- E. THE FOLLOWING DARCOM DRAWINGS ARE APPLICABLE FOR OUT-LOADING AND STORAGE OF THE ITEMS COVERED BY THIS APPENDIX.
 CARLOADING -----DRAWING 19-48-4115-5PA1002
 TRUCKLOADING -----DRAWING 19-48-4117-11PA1003
 STORAGE ----- DRAWING 19-48-4118-1-2-3-4-14-22PA1002
- F. FOR METHOD OF SECURING A STRAP CUTTER TO THE PALLET UNIT, SEE DARCOM DRAWING 19-48-4127-20P1000.
- G. IF ITEMS COVERED HEREIN ARE UNITIZED PRIOR TO ISSUANCE OF THIS APPENDIX, THE BOXES NEED NOT BE REUNITIZED SOLELY TO CONFORM TO THIS APPENDIX.
- H. THE UNITIZATION PROCEDURES DEPICTED HEREIN MAY ALSO BE USED FOR UNITIZING .30 CALIBER CARTRIDGES WHEN IDENTIFIED BY DIFFERENT NATIONAL STOCK NUMBERS (NSN) THAN WHAT IS SHOWN ON THE TITLE PAGE, PROVIDED THE BOX PACK DOES NOT VARY FROM WHAT IS DELINEATED HEREIN. THE EXPLOSIVE CLASSIFICATION OF OTHER ITEMS MAY BE DIFFERENT THAN WHAT IS SHOWN.

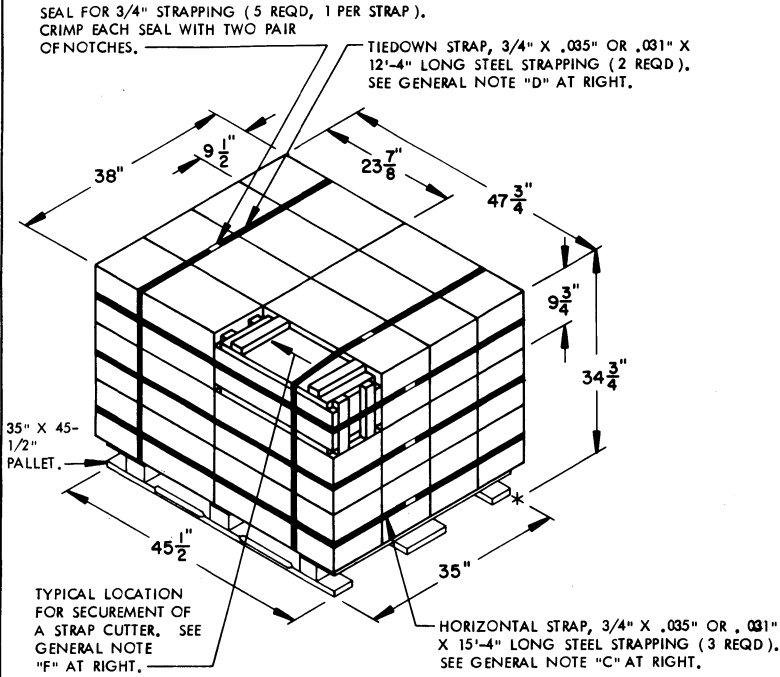

PALLET UNIT

SEE GENERAL NOTE "B" AT RIGHT.

| | |
|------------------------------------------------------------------|------------------|
| 24 BOXES OF .30 CALIBER CARTRIDGES (1,600 PER BOX) @ 37 LBS----- | 888 LBS (APPROX) |
| DUNNAGE----- | 6 LBS |
| PALLET----- | 65 LBS |
| TOTAL WEIGHT----- 959 LBS (APPROX) | |
| CUBE----- 36.5 CU FT (APPROX) | |

BILL OF MATERIAL

| | | |
|------------------------------|------------------|----------|
| PALLET, 35" X 45-1/2"----- | 1 REQD----- | 65 LBS |
| STEEL STRAPPING, 3/4"----- | 70.67' REQD----- | 5.05 LBS |
| SEAL FOR 3/4" STRAPPING----- | 5 REQD----- | NIL |

TIE PIECE, 1" X 4" X BOX WIDTH (2 REQD).
 NAIL TO LONGITUDINAL PIECES W/2-6d NAILS
 AT EACH END AND TO LATERAL PIECE W/1-
 6d NAIL.

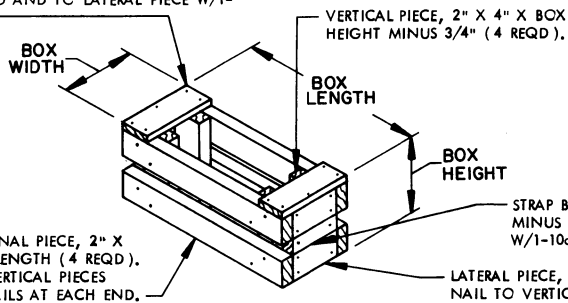

FILLER ASSEMBLY

(FOR MINUS ONE BOX)