

APPENDIX 68C

UNITIZATION PROCEDURES FOR BOXED AMMUNITION AND COMPONENTS ON 4-WAY ENTRY PALLETS

CARTRIDGE, .30 CALIBER, GRENADE, PACKED 2,400 PER
WOODEN BOX, UNITIZED 45 BOXES PER 40" X 48"
PALLET; APPROX BOX SIZE 17" L X 9 $\frac{3}{4}$ " W X 8 $\frac{5}{8}$ " H

PALLET UNIT DATA						
ITEMS INCLUDED		HAZARD CLASSIFICATION				WEIGHT (LBS)
NSN	DODIC	DOT CLASS	CG CLASS	QD CLASS	COMP GROUP	
1330- 00-028-5878	G837	C	I	1.4	S	2,478

NOTICE: THIS APPENDIX CANNOT STAND ALONE BUT MUST
BE USED IN CONJUNCTION WITH THE BASIC UNITIZATION
PROCEDURES DRAWING 19-48-4116-20PA1002.

REVISIONS			DRAFTSMAN <i>D. W. R.</i>	PROJ ENG <i>W. R. F.</i>
			CHECKER <i>SGG</i>	LOG ENGRG OFFICE <i>W. R. F.</i>
APPROVED, U. S. ARMY ARMAMENT MATERIEL READINESS COMMAND				
			DRSAR - LEP <i>[Signature]</i>	DRSAR - TMD <i>[Signature]</i>
APPROVED BY ORDER OF COMMANDING GENERAL, U. S. ARMY MATERIEL DEVELOPMENT AND READINESS COMMAND (DARCOM)				
<i>John L. Byrd</i> U. S. ARMY DEFENSE AMMUNITION CENTER AND SCHOOL				
U. S. ARMY DARCOM DRAWING				
FEBRUARY 1983				
CLASS	DIVISION	DRAWING	FILE	
19	48	4116/ 68C	20PA 1002	

DO NOT SCALE

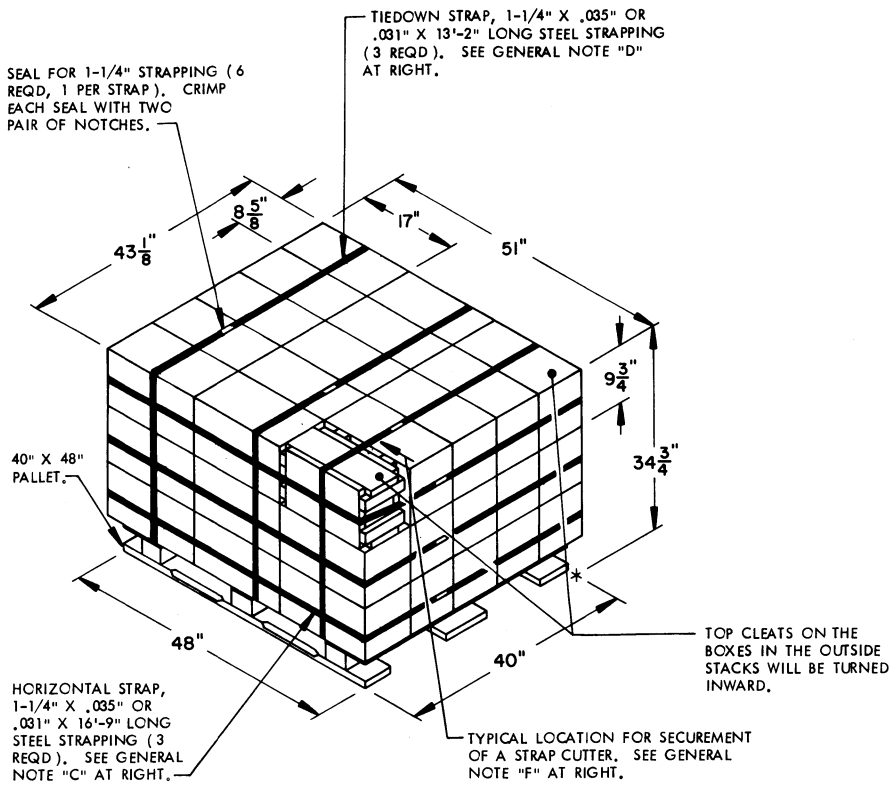

PALLET UNIT

SEE GENERAL NOTE "B" AT RIGHT.

45 BOXES OF .30 CALIBER CARTRIDGES (2,400 PER BOX) @ 53 LBS-----2,385 LBS (APPROX)
 DUNNAGE -----13 LBS
 PALLET -----80 LBS

TOTAL WEIGHT-----2,478 LBS (APPROX)
 CUBE -----44.2 CU FT (APPROX)

GENERAL NOTES

- A. THIS APPENDIX CANNOT STAND ALONE BUT MUST BE USED IN CONJUNCTION WITH THE BASIC UNITIZATION PROCEDURES DRAWING 19-48-4116-20PA1002. TO PRODUCE AN APPROVED UNIT LOAD, ALL PERTINENT PROCEDURES, SPECIFICATIONS AND CRITERIA SET FORTH WITHIN THE BASIC DRAWING WILL APPLY TO THE PROCEDURES DELINEATED IN THIS APPENDIX. ANY EXCEPTIONS TO THE BASIC PROCEDURES ARE SPECIFIED IN THIS APPENDIX.
- B. DIMENSIONS, CUBE AND WEIGHT OF A PALLET UNIT WILL VARY SLIGHTLY DEPENDING UPON THE ACTUAL DIMENSIONS OF THE BOXES AND THE WEIGHT OF THE SPECIFIC ITEM BEING UNITIZED.
- C. INSTALL EACH HORIZONTAL STRAP TO ENCIRCLE A LAYER OF BOXES ON THE PALLET. HORIZONTAL STRAPS MUST BE TENSIONED AND SEALED PRIOR TO APPLICATION OF TIEDOWN STRAPS.
- D. INSTALL EACH TIEDOWN STRAP TO PASS UNDER THE TOP DECK BOARDS OF THE PALLET AND TO BE LOCATED AS SHOWN. TIEDOWN STRAPS WILL NOT BE APPLIED UNTIL THE HORIZONTAL STRAPS HAVE BEEN TENSIONED AND SEALED.
- E. THE FOLLOWING DARCOM DRAWINGS ARE APPLICABLE FOR OUTLOADING AND STORAGE OF THE ITEMS COVERED BY THIS APPENDIX.
 CARLOADING-----DRAWING 19-48-4115-5PA1002
 TRUCKLOADING --- DRAWING 19-48-4117-11PA1003
 STORAGE-----DRAWING 19-48-4118-1-2-3-4-14-22PA1002
- F. FOR METHOD OF SECURING A STRAP CUTTER TO THE PALLET UNIT, SEE DARCOM DRAWING 19-48-4127-20P1000.
- G. IF ITEMS COVERED HEREIN ARE UNITIZED PRIOR TO ISSUANCE OF THIS APPENDIX, THE BOXES NEED NOT BE REUNITIZED SOLELY TO CONFORM TO THIS APPENDIX.
- H. THE UNITIZATION PROCEDURES DEPICTED HEREIN MAY ALSO BE USED FOR UNITIZING CARTRIDGES WHEN IDENTIFIED BY DIFFERENT NATIONAL STOCK NUMBERS (NSN) THAN WHAT IS SHOWN ON THE TITLE PAGE, PROVIDED THE BOX PACK DOES NOT VARY FROM WHAT IS DELINEATED HEREIN. THE EXPLOSIVE CLASSIFICATION OF OTHER ITEMS MAY BE DIFFERENT THAN WHAT IS SHOWN.

BILL OF MATERIAL

PALLET, 40" X 48"-----	1 REQD-----	80 LBS
STEEL STRAPPING, 1-1/4"-----	89.75' REQD-----	12.82 LBS
SEAL FOR 1-1/4" STRAPPING-----	6 REQD-----	NIL

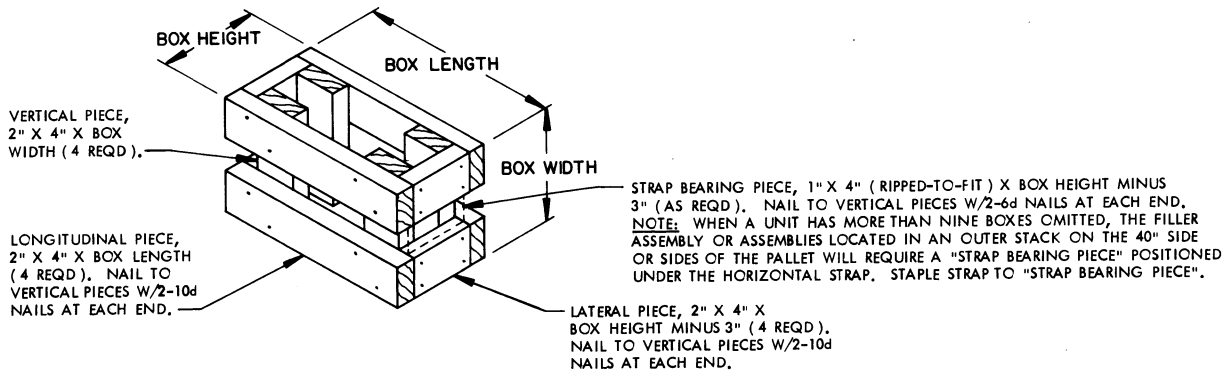

FILLER ASSEMBLY

(FOR MINUS ONE BOX)