

APPENDIX 66D

UNITIZATION PROCEDURES FOR BOXED AMMUNITION AND COMPONENTS ON 4-WAY ENTRY PALLETS

LAUNCHER, GRENADE, SMOKE, M243, PACKED ONE PER
PLYWOOD BOX, UNITIZED 12 BOXES PER 40" X 48"
PALLET; APPROX BOX SIZE 25"L X 20 $\frac{7}{8}$ "W X 14 $\frac{5}{8}$ "H

PALLET UNIT DATA						
ITEMS INCLUDED		HAZARD CLASSIFICATION				WEIGHT
NSN	DODIC	DOT CLASS	CG CLASS	QD CLASS	COMP GROUP	(LBS)
1055- 01-059-0560			INERT			1,501

NOTICE: THIS APPENDIX CANNOT STAND ALONE BUT MUST
BE USED IN CONJUNCTION WITH THE BASIC UNITIZATION
PROCEDURES DRAWING 19-48-4116-20PA1002.

REVISIONS			DRAFTSMAN <i>[Signature]</i>	PROJ ENG pt
			CHECKER <i>[Signature]</i>	LOG ENGRD OFFICE <i>[Signature]</i>
			APPROVED, U.S. ARMY ARMAMENT, MUNITIONS AND CHEMICAL COMMAND	
			<i>[Signature]</i>	<i>[Signature]</i>
			SMCAR - ESK AMBC - TMO	
			APPROVED BY ORDER OF COMMANDING GENERAL, U.S. ARMY MATERIAL COMMAND (AMC)	
			<i>[Signature]</i>	
			U.S. ARMY AMC DRAWING	
			SEPTEMBER 1987	
CLASS	DIVISION	DRAWING	FILE	
19	48	4116/ 66D	20PA 1002	

DO NOT SCALE

SEAL FOR 3/4" STRAPPING (4 REQD, 1 PER STRAP). CRIMP EACH SEAL WITH TWO PAIR OF NOTCHES.

LOAD STRAP, 3/4" X .035" OR .031" X 16'-9" LONG STEEL STRAPPING (2 REQD). SEE GENERAL NOTE "C" AT RIGHT.

TIEDOWN STRAP, 3/4" X .035" OR .031" X 15'-5" LONG STEEL STRAPPING (2 REQD). SEE GENERAL NOTE "D" AT RIGHT.

TYPICAL LOCATION FOR SECUREMENT OF A STRAP CUTTER. SEE GENERAL NOTE "F" AT RIGHT.

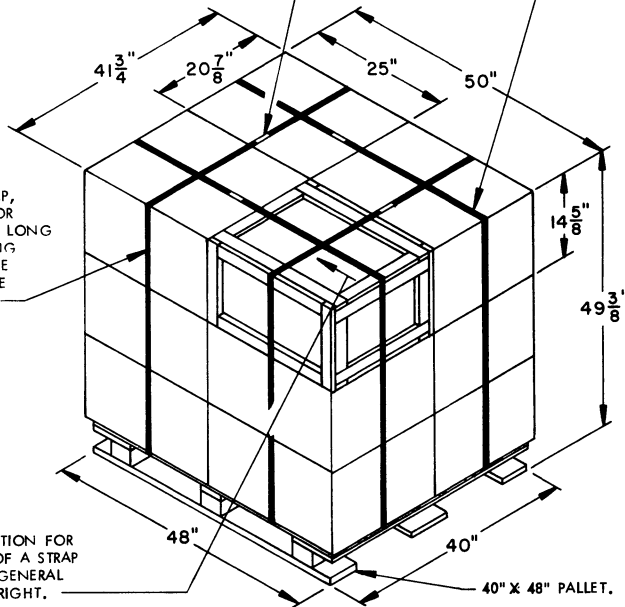

PALLET UNIT

SEE GENERAL NOTE "B" AT RIGHT,

12 BOXES OF GRENADE LAUNCHERS (1 PER BOX) @ 118 LBS-----	1,416 LBS (APPROX)
DUNNAGE-----	5 LBS
PALLET-----	80 LBS
TOTAL WEIGHT-----	1,501 LBS (APPROX)
CUBE -----	59.6 CU FT (APPROX)

GENERAL NOTES

- A. THIS APPENDIX CANNOT STAND ALONE BUT MUST BE USED IN CONJUNCTION WITH THE BASIC UNITIZATION PROCEDURES DRAWING 19-48-4116-208A1002. TO PRODUCE AN APPROVED UNIT LOAD, ALL PERTINENT PROCEDURES, SPECIFICATIONS AND CRITERIA SET FORTH WITHIN THE BASIC DRAWING WILL APPLY TO THE BASIC PROCEDURES DELINEATED IN THIS APPENDIX. ANY EXCEPTIONS TO THE BASIC PROCEDURES ARE SPECIFIED IN THE APPENDIX.
- B. DIMENSIONS, CUBE AND WEIGHT OF A PALLET UNIT WILL VARY SLIGHTLY DEPENDING UPON THE ACTUAL DIMENSIONS OF THE BOXES AND THE WEIGHT OF THE SPECIFIC ITEM BEING UNITIZED.
- C. THE LOAD STRAPS WILL BE THREADED THROUGH THE STRAP SLOTS OF THE PALLET. LOAD STRAPS MUST BE TENSIONED AND SEALED PRIOR TO THE APPLICATION OF TIEDOWN STRAPS.
- D. INSTALL EACH TIEDOWN STRAP TO PASS UNDER THE TOP DECK BOARDS OF THE PALLET AND TO BE LOCATED AS SHOWN. TIEDOWN STRAPS WILL NOT BE APPLIED UNTIL THE LOAD STRAPS HAVE BEEN TENSIONED AND SEALED.
- E. THE FOLLOWING AMC (DARCOM) DRAWINGS ARE APPLICABLE FOR OUTLOADING AND STORAGE OF ITEMS COVERED BY THIS APPENDIX.
 CARLOADING ----- DRAWING 19-48-4115-5PA1002
 TRUCKLOADING ----- DRAWING 19-48-4117-11PA1003
 STORAGE ----- DRAWING 19-48-4118-1-2-3-4-14-22PA1002
- F. FOR METHOD OF SECURING A STRAP CUTTER TO THE PALLET UNIT, SEE DARCOM DRAWING 19-48-4127-20P1000.
- G. IF ITEMS COVERED HEREIN ARE UNITIZED PRIOR TO ISSUANCE OF THIS APPENDIX, THE BOXES NEED NOT BE REUNITIZED SOLELY TO CONFORM TO THIS APPENDIX.
- H. THE UNITIZATION PROCEDURES DEPICTED HEREIN MAY ALSO BE USED FOR UNITIZING GRENADE LAUNCHERS WHEN IDENTIFIED BY DIFFERENT NATIONAL STOCK NUMBERS (NSN) THAN WHAT IS SHOWN ON THE TITLE PAGE, PROVIDED THE BOX PACK DOES NOT VARY FROM WHAT IS DELINEATED HEREIN. THE EXPLOSIVE CLASSIFICATION OF OTHER ITEMS MAY BE DIFFERENT THAN WHAT IS SHOWN.
- J. WHEN THE UNIT LOAD DEPICTED AT LEFT IS TO BE USED FOR UNITIZING MARINE CORPS AMMUNITION, ONE LAYER OF BOXES MUST BE OMITTED, TIEDOWN STRAP LENGTHS MUST BE DECREASED TO 12'-11", AND LOAD STRAP LENGTHS MUST BE DECREASED TO 14'-4". THIS WILL RESULT IN AN OVERALL UNIT HEIGHT OF 34-3/4", A GROSS UNIT WEIGHT OF 1,028 POUNDS, AND A UNIT CUBE OF 42.0 CUBIC FEET. ADDITIONALLY, THE UNIT LOAD MAY BE MODIFIED AS DESCRIBED WHEN BEING SHIPPED BY MILVAN OR COMMERCIAL INTERMODAL FREIGHT CONTAINER. THE DETERMINATION TO REDUCE THE LOAD BY A LAYER FOR TRANSPORTATION WILL BE MADE BY THE RESPONSIBLE COMMAND AND WILL BE BASED UPON THE ECONOMICS OF TRANSPORTATION AND HANDLING.
- K. THE STYLE 1 PALLET DELINEATED IN THE DETAIL AT LEFT NEED NOT HAVE CHAMFERS OR STRAP SLOTS AS SPECIFIED WITHIN MILITARY SPECIFICATION MIL-P-15011 WHEN USED FOR THE UNITIZATION OF THE ITEMS COVERED BY THIS APPENDIX.

BILL OF MATERIAL

PALLET, 40" X 48"-----	1 REQD-----	80 LBS
STEEL STRAPPING, 3/4"-----	64.33' REQD-----	4.60 LBS
SEAL FOR 3/4" STRAPPING-----	4 REQD-----	NIL

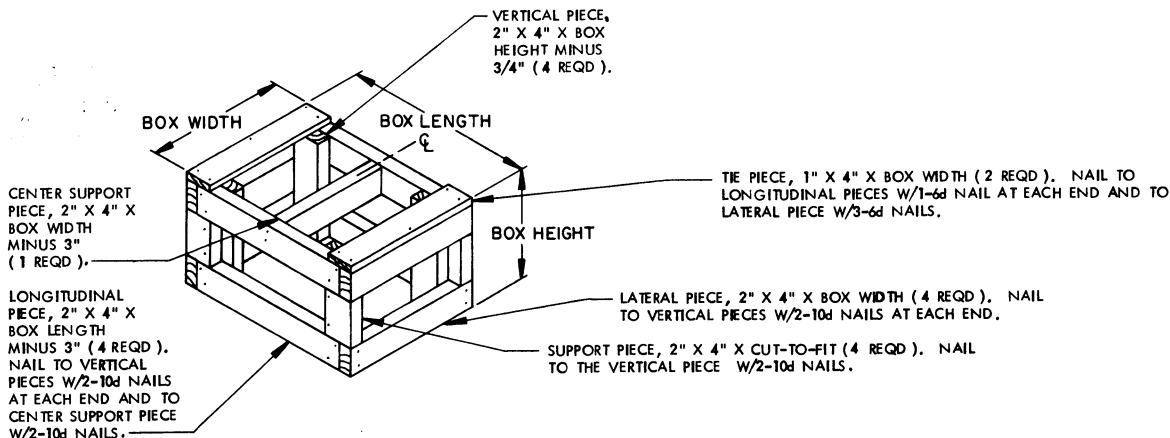

FILLER ASSEMBLY
(FOR MINUS ONE BOX)