

# APPENDIX 66B

## UNITIZATION PROCEDURES FOR BOXED AMMUNITION AND COMPONENTS ON 4-WAY ENTRY PALLETS

LAUNCHER, GRENADE, SMOKE, M259, PACKED  
ONE PER PLYWOOD BOX, UNITIZED 16 BOXES PER  
42" X 53" PALLET; APPROX BOX SIZE 22 $\frac{1}{4}$ " L X 15" W  
X 14 $\frac{1}{4}$ " H

PALLET UNIT DATA						
ITEMS INCLUDED		HAZARD CLASSIFICATION				WEIGHT
NSN	DODIC	DOT CLASS	CG CLASS	QD CLASS	COMP GROUP	( LBS )
1055-01-107-7501			INERT			593

### REVISION

REVISION NO. 1, DATED DECEMBER 1986, CONSISTS OF:

1. DELETING ITEM BY NATIONAL STOCK NUMBER FROM "PALLET UNIT DATA" CHART.
2. UPDATING DRAWING TITLE.

**NOTICE:** THIS APPENDIX CANNOT STAND ALONE BUT MUST BE USED IN CONJUNCTION WITH THE BASIC UNITIZATION PROCEDURES DRAWING 19-48-4116-20PA1002.

**DO NOT SCALE**

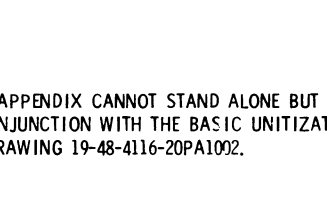
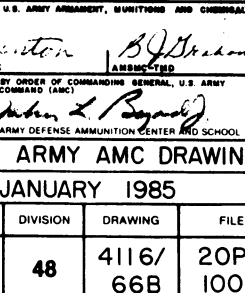
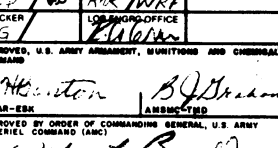
REVISIONS				DRAFTSMAN EJP/BS	PROJ ENG RJR/WRF
1	DEC 86	WRF 2086	Martin Blakemore AMCAR-ESK	SYG	LOGS/PROJ OFFICE K. Wilson
APPROVED, U.S. ARMY AMMUNITION, MUNITIONS AND CHEMICAL CENTER					
 					
AMCAR-ESK					
APPROVED BY ORDER OF COMMANDING GENERAL, U.S. ARMY MATERIEL COMMAND (AMC)					
					
U.S. ARMY AMC DRAWING					
JANUARY 1985					
CLASS	DIVISION	DRAWING	FILE		
19	48	4116/ 66B	20PA 1002		

**GENERAL NOTES**

- A. THIS APPENDIX CANNOT STAND ALONE BUT MUST BE USED IN CONJUNCTION WITH THE BASIC UNITIZATION PROCEDURES DRAWING 19-48-4116-20PA1002. TO PRODUCE AN APPROVED UNIT LOAD, ALL PERTINENT PROCEDURES, SPECIFICATIONS, AND CRITERIA SET FORTH WITHIN THE BASIC DRAWING WILL APPLY TO THE PROCEDURES DELINEATED IN THIS APPENDIX. ANY EXCEPTIONS TO THE BASIC PROCEDURES ARE SPECIFIED IN THIS APPENDIX.
- B. DIMENSIONS, CUBE AND WEIGHT OF A PALLET UNIT WILL VARY SLIGHTLY DEPENDING UPON THE ACTUAL DIMENSIONS OF THE BOXES AND THE WEIGHT OF THE SPECIFIC ITEM BEING UNITIZED.
- C. THE LOAD STRAPS MAY BE THREADED THROUGH THE STRAP SLOTS OF A PALLET OR PRE-POSITIONED ON THE PALLET DECK PRIOR TO PLACING BOXES ON THE PALLET. LOAD STRAPS WILL BE TENSIONED AND SEALED PRIOR TO TIEDOWN STRAPS.
- D. INSTALL EACH TIEDOWN STRAP TO PASS UNDER THE TOP DECK BOARDS OF THE PALLET AND TO BE LOCATED AS SHOWN. TIEDOWN STRAPS WILL NOT BE APPLIED UNTIL AFTER LOAD STRAPS HAVE BEEN TENSIONED AND SEALED.
- E. THE FOLLOWING AMC (DARCOM) DRAWINGS ARE APPLICABLE FOR OUTLOADING AND STORAGE OF THE ITEMS COVERED BY THIS APPENDIX.  
  - CARLOADING ----- DRAWING 19-48-4115-5PA1002.
  - TRUCKLOADING -- DRAWING 19-48-4117-11PA1003.
  - STORAGE ----- DRAWING 19-48-4118-1-2-3-4-14-22PA1002.
- F. FOR METHOD OF SECURING A STRAP CUTTER TO THE PALLET UNIT, SEE DARCOM DRAWING 19-48-4127-20P1000.
- G. IF ITEMS COVERED HEREIN ARE UNITIZED PRIOR TO ISSUANCE OF THIS APPENDIX, THE BOXES NEED NOT BE REUNITIZED SOLELY TO CONFORM TO THIS APPENDIX.
- H. THE UNITIZATION PROCEDURES DEPICTED HEREIN MAY ALSO BE USED FOR UNITIZING GRENADE LAUNCHERS WHEN IDENTIFIED BY DIFFERENT NATIONAL STOCK NUMBERS (NSN) THAN WHAT IS SHOWN ON THE TITLE PAGE, PROVIDED THE BOX PACK DOES NOT VARY FROM WHAT IS DELINEATED HEREIN. THE EXPLOSIVE CLASSIFICATION OF OTHER ITEMS MAY BE DIFFERENT THAN WHAT IS SHOWN.
- J. THE STYLE 1B PALLET DELINEATED IN THE DETAIL AT LEFT NEED NOT HAVE CHAMFERS OR STRAP SLOTS AS SPECIFIED WITHIN MILITARY SPECIFICATION MIL-P-15011 WHEN USED FOR THE UNITIZATION OF THE ITEMS COVERED BY THIS APPENDIX.

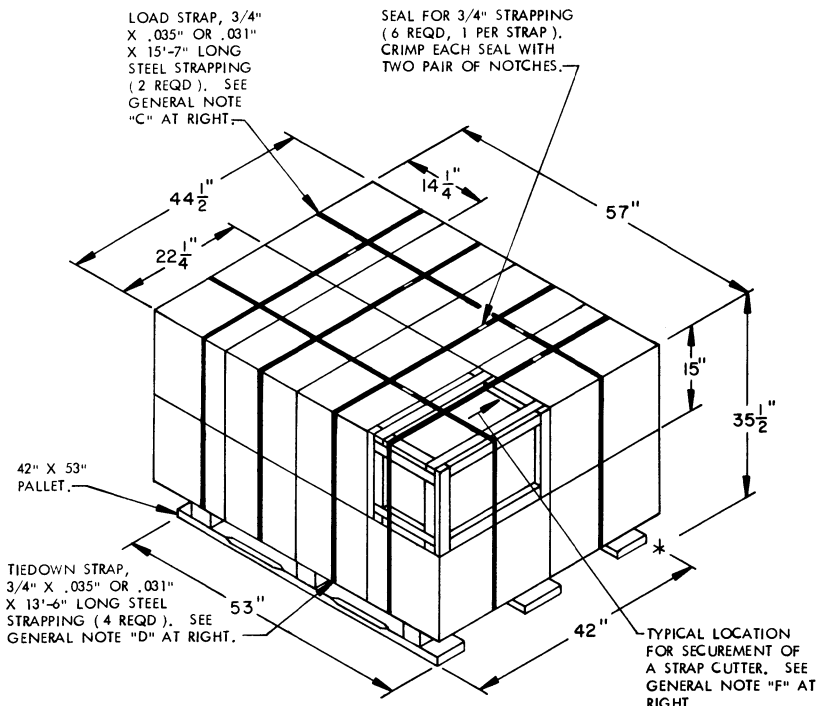

**PALLET UNIT**

SEE GENERAL NOTE "B" AT RIGHT.

16 BOXES OF GRENADE LAUNCHER (1 PER BOX) @ 31 LBS ----- 496 LBS (APPROX)  
 DUNNAGE ----- 7 LBS  
 PALLET ----- 90 LBS

TOTAL WEIGHT ----- 593 LBS (APPROX)  
 CUBE ----- 52.1 CU FT (APPROX)

**BILL OF MATERIAL**

PALLET, 42" X 53" -----	1 REQD -----	90 LBS
STEEL STRAPPING, 3/4" -----	85.17' REQD -----	6.08 LBS
SEAL FOR 3/4" STRAPPING -----	6 REQD -----	NIL

