

APPENDIX 66

UNITIZATION PROCEDURES FOR BOXED AMMUNITION AND COMPONENTS ON 4-WAY ENTRY PALLETS

LAUNCHER, XMI76, WITH GRENADES, PACKED 8 PER
WOODEN BOX, UNITIZED 24 BOXES PER 40" X 48"
PALLET; APPROX BOX SIZE 19½" L X 18" W X 11¼" H

PALLET UNIT DATA						
ITEMS INCLUDED		HAZARD CLASSIFICATION				WEIGHT (LBS)
NSN	DODIC	DOT CLASS	CG CLASS	QD CLASS	COMP GROUP	
1330- 00-930-8945	H050	B	II-D	(04)1.2	H	2,041

NOTICE: THIS APPENDIX CANNOT STAND ALONE BUT MUST BE USED IN CONJUNCTION WITH THE BASIC UNITIZATION PROCEDURES DRAWING 19-48-4116-20PA1002.

REVISIONS				DRAFTSMAN DJB/pt	PROJ ENG WRF/WW
				CHECKER WRF/WW	LOG ENGRG OFFICE WRF/WW
				APPROVED, U. S. ARMY ARMAMENT MATERIEL READINESS COMMAND	
				DRSAR - LEP <i>W. A. Renton</i>	DRSAR - TMD <i>W. A. Renton</i>
				APPROVED BY ORDER OF COMMANDING GENERAL, U. S. ARMY MATERIEL DEVELOPMENT AND READINESS COMMAND (DARCOM)	
				<i>William F. Smith</i> U. S. ARMY DEFENSE AMMUNITION CENTER AND SCHOOL	
				U. S. ARMY DARCOM DRAWING	
				MARCH 1983	
CLASS	DIVISION	DRAWING	FILE		
19	48	4116/ 66	20PA 1002		

DO NOT SCALE

GENERAL NOTES

- A. THIS APPENDIX CANNOT STAND ALONE BUT MUST BE USED IN CONJUNCTION WITH THE BASIC UNITIZATION PROCEDURES DRAWING 19-48-4116-20PA1002. TO PRODUCE AN APPROVED UNIT LOAD, ALL PERTINENT PROCEDURES, SPECIFICATIONS AND CRITERIA SET FORTH WITHIN THE BASIC DRAWING WILL APPLY TO THE PROCEDURES DELINEATED IN THIS APPENDIX. ANY EXCEPTIONS TO THE BASIC PROCEDURES ARE SPECIFIED IN THIS APPENDIX.
- B. DIMENSIONS, CUBE AND WEIGHT OF A PALLET UNIT WILL VARY SLIGHTLY DEPENDING UPON THE ACTUAL DIMENSIONS OF THE BOXES AND THE WEIGHT OF THE SPECIFIC ITEM BEING UNITIZED.
- C. THE LOAD STRAPS WILL BE THREADED THROUGH THE STRAP SLOTS OF A PALLET PRIOR TO PLACING BOXES ON THE PALLET. LOAD STRAPS MUST BE TENSIONED AND SEALED PRIOR TO APPLICATION OF TIEDOWN STRAPS.
- D. INSTALL EACH TIEDOWN STRAP TO PASS UNDER THE TOP DECK BOARDS OF THE PALLET AND TO BE LOCATED AS SHOWN. TIEDOWN STRAPS WILL NOT BE APPLIED UNTIL THE LOAD STRAPS HAVE BEEN TENSIONED AND SEALED.
- E. THE FOLLOWING DARCOM DRAWINGS ARE APPLICABLE FOR OUTLOADING AND STORAGE OF THE ITEMS COVERED BY THIS APPENDIX.
 CARLOADING ----- DRAWING 19-48-4115-5PA1002
 TRUCKLOADING ----- DRAWING 19-48-4117-11PA1003
 STORAGE ----- DRAWING 19-48-4118-1-2-3-4
 14-22PA1002
- F. FOR METHOD OF SECURING A STRAP CUTTER TO THE PALLET UNIT, SEE DARCOM DRAWING 19-48-4127-20P1000.
- G. IF ITEMS COVERED HEREIN ARE UNITIZED PRIOR TO ISSUANCE OF THIS APPENDIX, THE BOXES NEED NOT BE REUNITIZED SOLELY TO CONFORM TO THIS APPENDIX.
- H. THE UNITIZATION PROCEDURES DEPICTED HEREIN MAY ALSO BE USED FOR UNITIZING LAUNCHER AND GRENADES WHEN IDENTIFIED BY DIFFERENT NATIONAL STOCK NUMBERS (NSN) THAN WHAT IS SHOWN ON THE TITLE PAGE, PROVIDED THE BOX PACK DOES NOT VARY FROM WHAT IS DELINEATED HEREIN. THE EXPLOSIVE CLASSIFICATION OF OTHER ITEMS MAY BE DIFFERENT THAN WHAT IS SHOWN.

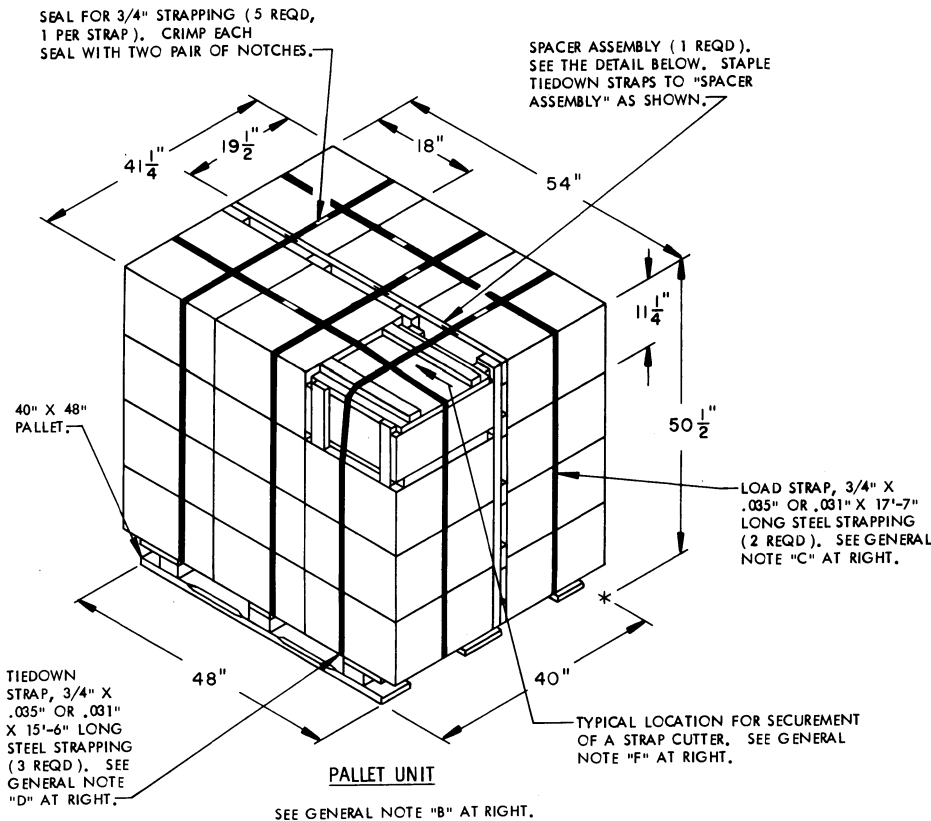

24 BOXES OF LAUNCHER AND GRENADES (8 PER WOODEN BOX) @ 80 LBS	-----	1,920 LBS (APPROX)
DUNNAGE	-----	41 LBS
PALLET	-----	80 LBS
TOTAL WEIGHT	-----	2,041 LBS (APPROX)
CUBE	-----	65.1 CU FT (APPROX)

BILL OF MATERIAL		
LUMBER	LINEAR FEET	BOARD FEET
1" X 4"	22.50	7.50
2" X 4"	15.00	10.00
NAILS	NO. REQD	POUNDS
6d (2")	40	0.24
PALLET, 40" X 48"	1 REQD	80 LBS
STEEL STRAPPING, 3/4"	81.67' REQD	5.83 LBS
SEAL FOR 3/4" STRAPPING	5 REQD	NIL
STAPLE, 15/16" X 3/4"	3 REQD	NIL

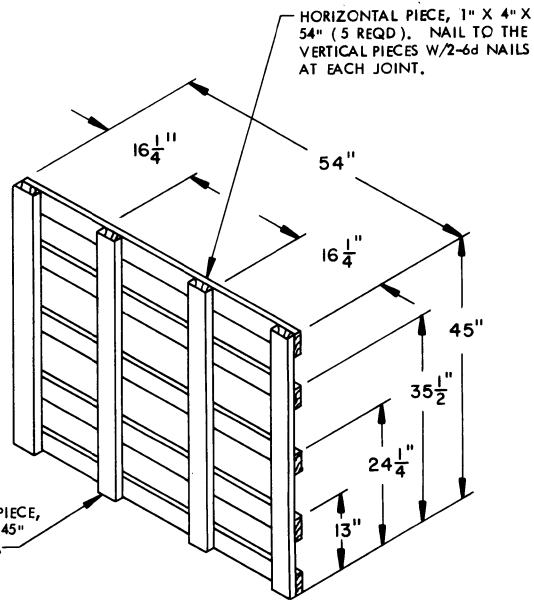

SPACER ASSEMBLY
(ONE REQD)

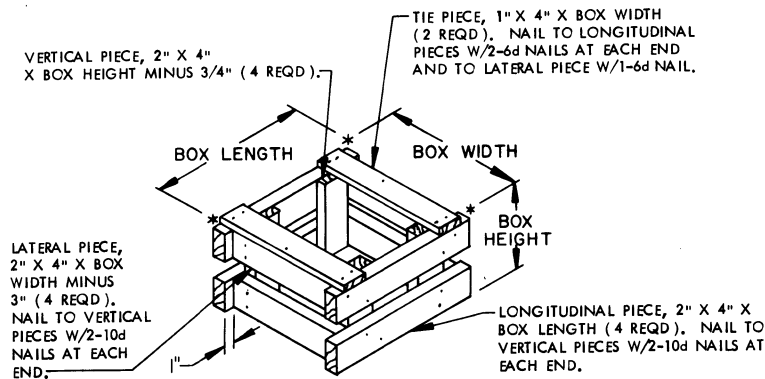

FILLER ASSEMBLY
(FOR MINUS ONE BOX)