

APPENDIX 65N *

UNITIZATION PROCEDURES FOR BOXED AMMUNITION AND COMPONENTS ON 4-WAY ENTRY PALLETS

GRENADE, HAND, OFFENSIVE, PACKED 50 PER
WOODEN BOX, UNITIZED 30 BOXES PER 40" X 48"
PALLET; APPROX BOX SIZE 25 $\frac{3}{4}$ " L X 13 $\frac{1}{2}$ " W X 6 $\frac{7}{8}$ " H

PALLET UNIT DATA						
ITEMS INCLUDED		HAZARD CLASSIFICATION ①				WEIGHT (LBS)
NSN	DODIC	DOT CLASS	CG CLASS	QD CLASS	COMP GROUP	
1330 -						
00-028-5844	G910	A	IV	1.1	D	1198
00-028-5845	G910	A	IV	1.1	D	1708
00-028-5896	G910	A	IV	1.1	D	1708

① HAZARD CLASSIFICATION DATA CONTAINED IN THE ABOVE CHART IS FOR GUIDANCE AND INFORMATION PURPOSES ONLY. VERIFICATION OF THE SPECIFIED DATA SHOULD BE MADE BY CONSULTING THE MOST RECENT JOINT HAZARD CLASSIFICATION SYSTEM LISTING OR OTHER APPROVED LISTING(S).

* THE PROCEDURES DELINEATED WITHIN THIS APPENDIX FOR THE ITEMS SPECIFIED IN THE "PALLET UNIT DATA" CHART ARE FOR MARINE CORPS USE ONLY AND ARE NOT INTENDED TO BE USED BY ANY OTHER SERVICE WITHOUT APPROPRIATE COMMAND APPROVAL

NOTICE: THIS APPENDIX CANNOT STAND ALONE BUT MUST BE USED IN CONJUNCTION WITH THE BASIC UNITIZATION PROCEDURES DRAWING 19-48-4116-20PA1002.

DO NOT SCALE

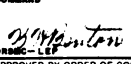
REVISIONS				DRAFTSMAN JG	PROJ ENG AW
				CHECKER	LOG ENGRS OFFICE
APPROVED BY ORDER OF COMMANDING GENERAL, U. S. ARMY MATERIEL DEVELOPMENT AND READINESS COMMAND (DARCOM)					
 U. S. ARMY DEFENSE AMMUNITION CENTER AND SCHOOL					
U. S. ARMY DARCOM DRAWING					
NOVEMBER 1983					
CLASS	DIVISION	DRAWING	FILE		
19	48	4116/ 65N	20PA 1002		

GENERAL NOTES

- A. THIS APPENDIX CANNOT STAND ALONE BUT MUST BE USED IN CONJUNCTION WITH THE BASIC UNITIZATION PROCEDURES DRAWING 19-48-4116-20PA1002. TO PRODUCE AN APPROVED UNIT LOAD, ALL PERTINENT PROCEDURES, SPECIFICATION AND CRITERIA SET FORTH WITHIN THE BASIC DRAWING WILL APPLY TO THE PROCEDURES DELINEATED IN THIS APPENDIX. ANY EXCEPTIONS TO THE BASIC PROCEDURES ARE SPECIFIED IN THIS APPENDIX.
- B. DIMENSIONS, CUBE AND WEIGHT OF A PALLET UNIT WILL VARY SLIGHTLY DEPENDING UPON THE ACTUAL DIMENSIONS OF THE BOXES AND THE WEIGHT OF THE SPECIFIC ITEM BEING UNITIZED.
- C. THE LOAD STRAPS MAY BE THREADED THROUGH THE STRAP SLOTS OF A PALLET OR PRE-POSITIONED ON THE PALLET DECK PRIOR TO PLACING BOXES ON THE PALLET.
- D. INSTALL EACH TIEDOWN STRAP TO PASS UNDER THE TOP DECK BOARDS OF THE PALLET AND TO BE LOCATED AS SHOWN. TIEDOWN STRAPS WILL BE TENSIONED AND SEALED PRIOR TO APPLICATION OF LOAD STRAPS.
- E. THE FOLLOWING DARCOM DRAWINGS ARE APPLICABLE FOR OUTLOADING AND STORAGE OF THE ITEMS COVERED BY THIS APPENDIX.
 - CARLOADING ----- DRAWING 19-48-4115-5PA1002
 - TRUCKLOADING ----- DRAWING 19-48-4117-11PA1003
 - STORAGE ----- DRAWING 19-48-411E-1-2-3-4-14-22PA1002
- F. FOR METHOD OF SECURING A STRAP CUTTER TO THE PALLET UNIT, SEE DARCOM DRAWING 19-48-4127-20P1000.
- G. IF ITEMS COVERED HEREIN ARE UNITIZED PRIOR TO ISSUANCE OF THIS APPENDIX, THE BOXES NEED NOT BE REUNITIZED SOLELY TO CONFORM TO THIS APPENDIX.
- H. THE UNITIZATION PROCEDURES DEPICTED HEREIN MAY ALSO BE USED FOR UNITIZING HAND GRENADES WHEN IDENTIFIED BY DIFFERENT NATIONAL STOCK NUMBERS (NSN) THAN WHAT IS SHOWN ON THE TITLE PAGE, PROVIDED THE BOX PACK DOES NOT VARY FROM WHAT IS DELINEATED HEREIN. THE EXPLOSIVE CLASSIFICATION OF OTHER ITEMS MAY BE DIFFERENT THAN WHAT IS SHOWN.

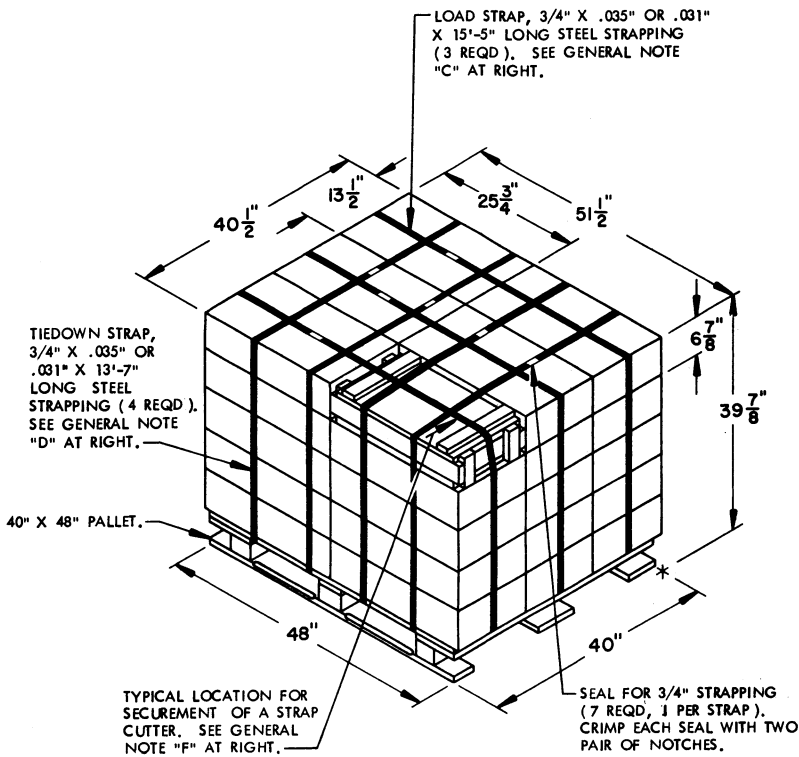

PALLET UNIT

SEE GENERAL NOTE "B" AT RIGHT.

30 BOXES OF HAND GRENADE (50 PER BOX) @ 54 LBS	-----	1,620 LBS (APPROX)
DUNNAGE	-----	8 LBS
PALLET	-----	80 LBS

TOTAL WEIGHT	-----	1,708 LBS (APPROX)
CUBE	-----	48.1 CU. FT. (APPROX)

BILL OF MATERIAL

PALLET, 40" X 48"	-----	1 REQD	-----	80 LBS
STEEL STRAPPING, 3/4"	-----	100.58' REQD	-----	7.19 LBS
SEAL FOR 3/4" STRAPPING	-----	7 REQD	-----	NIL

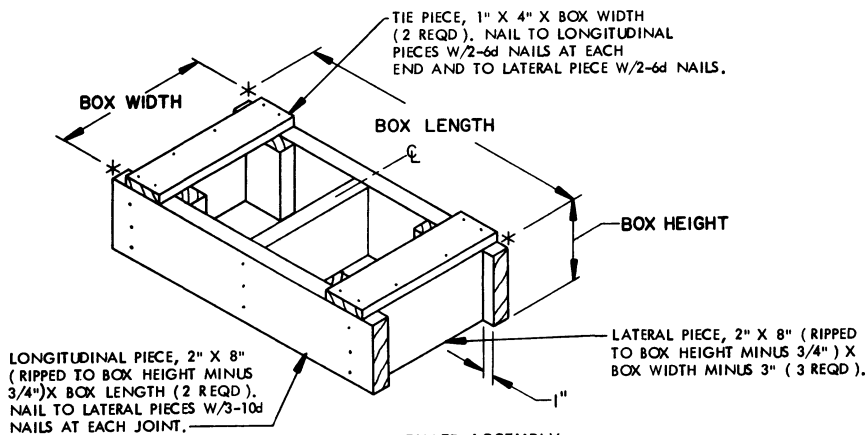

FILLER ASSEMBLY

(FOR MINUS ONE BOX)