

APPENDIX 65K

UNITIZATION PROCEDURES FOR BOXED AMMUNITION AND COMPONENTS ON 4-WAY ENTRY PALLETS

GRENADE, HAND, PACKED 40 PER WOODEN BOX,
UNITIZED 27 BOXES PER 40" X 48" PALLET; APPROX
BOX SIZE 18 $\frac{1}{2}$ " L X 13 $\frac{7}{8}$ " W X 13" H

PALLET UNIT DATA						
ITEMS INCLUDED		HAZARD CLASSIFICATION				WEIGHT (LBS)
NSN	DODIC	DOT CLASS	CG CLASS	QD CLASS	COMP GROUP	
1330- 00-028-5840	G890	A	IV	(08)1.1	F	2,382

NOTICE: THIS APPENDIX CANNOT STAND ALONE BUT MUST BE USED IN CONJUNCTION WITH THE BASIC UNITIZATION PROCEDURES DRAWING 19-48-4116-20PA1002.

REVISIONS				DRAFTSMAN	PROJ ENG
				<i>[Signature]</i>	<i>WRE/lin</i>
				CHECKER	LOG ENGRG OFFICE
				<i>[Signature]</i>	<i>[Signature]</i>
APPROVED U. S. ARMY ARMAMENT MATERIEL READINESS COMMAND					
				<i>[Signature]</i>	<i>[Signature]</i>
				DARSAR - LEP	DARSAR - TMD
APPROVED BY ORDER OF COMMANDING GENERAL, U. S. ARMY MATERIEL DEVELOPMENT AND READINESS COMMAND (DARCOM)					
				<i>[Signature]</i>	
U. S. ARMY DARCOM DRAWING					
APRIL 1982					
CLASS	DIVISION	DRAWING	FILE		
19	48	4116/ 65K	20PA 1002		

DO NOT SCALE

GENERAL NOTES

- A. THIS APPENDIX CANNOT STAND ALONE BUT MUST BE USED IN CONJUNCTION WITH THE BASIC UNITIZATION PROCEDURES DRAWING 19-48-4116-20PA1002. TO PRODUCE AN APPROVED UNIT LOAD, ALL PERTINENT PROCEDURES, SPECIFICATIONS AND CRITERIA SET FORTH WITHIN THE BASIC DRAWING WILL APPLY TO THE PROCEDURES DELINEATED IN THIS APPENDIX.
- B. DIMENSIONS, CUBE AND WEIGHT OF A PALLET UNIT WILL VARY SLIGHTLY DEPENDING UPON THE ACTUAL DIMENSIONS OF THE BOXES AND THE WEIGHT OF THE SPECIFIC ITEM BEING UNITIZED.
- C. THE LOAD STRAPS MUST BE PRE-POSITIONED ON THE PALLET DECK PRIOR TO PLACING BOXES ON THE PALLET. LOAD STRAPS MUST NOT BE TENSIONED AND SEALED UNTIL TIEDOWN STRAPS HAVE BEEN TENSIONED AND SEALED.
- D. INSTALL EACH TIEDOWN STRAP TO PASS UNDER THE TOP DECK BOARDS OF THE PALLET AND TO BE LOCATED AS SHOWN.
- E. THE FOLLOWING DARCOM DRAWINGS ARE APPLICABLE FOR OUTLOADING AND STORAGE OF THE ITEMS COVERED BY THIS APPENDIX.
 - CARLOADING ----- DRAWING 19-48-4115-5PA1002
 - TRUCKLOADING ----- DRAWING 19-48-4117-11PA1003
 - STORAGE ----- DRAWING 19-48-4118-1-2-3-4-14-22PA1002
- F. FOR METHOD OF SECURING A STRAP CUTTER TO THE PALLET UNIT, SEE DARCOM DRAWING 19-48-4127-20P1000.
- G. IF ITEMS COVERED HEREIN ARE UNITIZED PRIOR TO ISSUANCE OF THIS APPENDIX, THE BOXES NEED NOT BE REUNITIZED SOLELY TO CONFORM TO THIS APPENDIX.
- H. THE UNITIZATION PROCEDURES DEPICTED HEREIN MAY ALSO BE USED FOR UNITIZING HAND GRENADES WHEN IDENTIFIED BY DIFFERENT NATIONAL STOCK NUMBERS (NSN) THAN WHAT IS SHOWN ON THE TITLE PAGE, PROVIDED THE BOX PACK DOES NOT VARY FROM WHAT IS DELINEATED HEREIN. THE EXPLOSIVE CLASSIFICATION OF OTHER ITEMS MAY BE DIFFERENT THAN WHAT IS SHOWN.

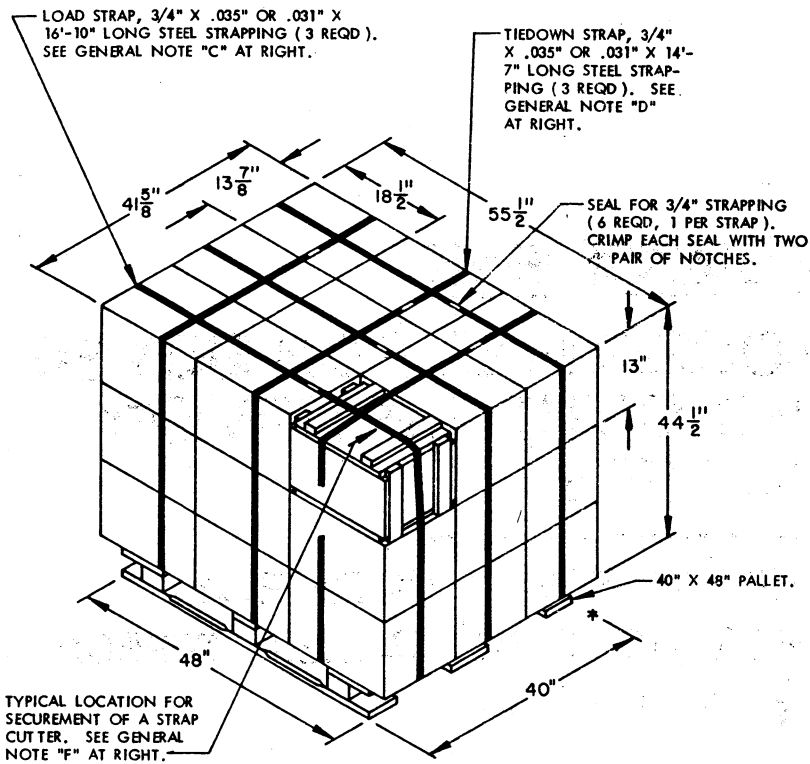

PALLET UNIT

SEE GENERAL NOTE "B" AT RIGHT.

27 BOXES OF HAND GRENADES (40 PER BOX) @ 85 LBS -----	2,295 LBS (APPROX)
DUNNAGE -----	7 LBS
PALLET -----	80 LBS
TOTAL WEIGHT -----	2,382 LBS (APPROX)
CUBE -----	59.5 CU FT (APPROX)

BILL OF MATERIAL

PALLET, 40" X 48" -----	1 REQD -----	80 LBS
STEEL STRAPPING, 3/4" -----	94.25' REQD -----	6.73 LBS
SEAL FOR 3/4" STRAPPING -----	6 REQD -----	NIL

TIE PIECE, 1" X 4" X BOX WIDTH (2 REQD).
NAIL TO LONGITUDINAL PIECES W/2-6d NAILS
AT EACH END AND TO LATERAL PIECE W/1-6d NAIL.

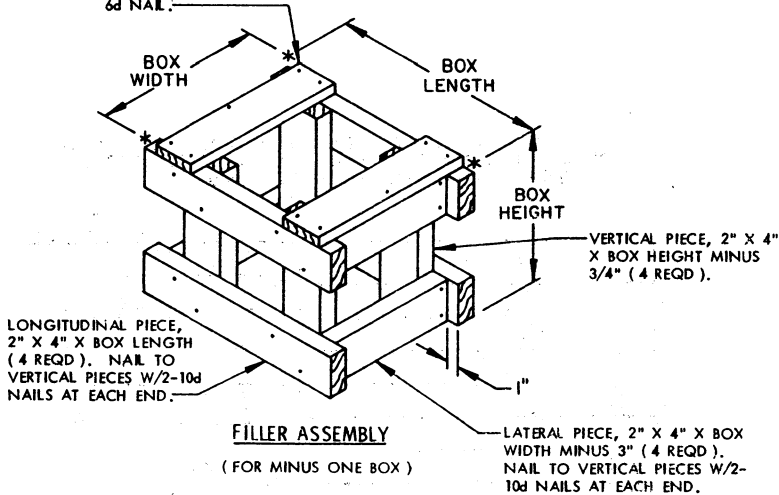

FILLER ASSEMBLY

(FOR MINUS ONE BOX)