

APPENDIX 65H

UNITIZATION PROCEDURES FOR BOXED AMMUNITION AND COMPONENTS ON 4-WAY ENTRY PALLETS

HAND GRENADE, PACKED 25 PER WOODEN BOX,
UNITIZED 36 BOXES PER 35" X 45 $\frac{1}{2}$ " PALLET;
APPROX BOX SIZE 17 $\frac{3}{4}$ " L X 16 $\frac{1}{4}$ " W X 7 $\frac{1}{2}$ " H

| PALLET UNIT DATA | | | | | | |
|------------------|-------|------------------------------------|----------|----------|------------|---------|
| ITEMS INCLUDED | | HAZARD CLASSIFICATION ^① | | | | WEIGHT |
| NSN | DODIC | DOT CLASS | CG CLASS | QD CLASS | COMP GROUP | (LBS) |
| 1330-00-028-5832 | G890 | A | IV | (08) 1.1 | F | 2, 123 |
| 00-028-5837 | G890 | A | IV | (08) 1.1 | F | 2, 231 |
| 00-301-1970 | G890 | A | IV | (08) 1.1 | F | 2, 231 |

NOTICE: THIS APPENDIX CANNOT STAND ALONE BUT MUST BE USED IN CONJUNCTION WITH THE BASIC UNITIZATION PROCEDURES DRAWING 19-48-4116-20PA1002.

① HAZARD CLASSIFICATION DATA CONTAINED IN THE ABOVE CHART IS FOR GUIDANCE AND INFORMATIONAL PURPOSES ONLY. VERIFICATION OF THE SPECIFIED DATA SHOULD BE MADE BY CONSULTING THE MOST RECENT JOINT HAZARD CLASSIFICATION SYSTEM LISTING OR OTHER APPROVED LISTING(S).

DO NOT SCALE

| REVISIONS | | | | DRAFTSMAN | PROJ. ENG. | | |
|-----------|--|--|--|--|--------------------|--------------|--------------|
| | | | | <i>[Signature]</i> | <i>[Signature]</i> | | |
| | | | | CHECKER | LOG. ENGINE OFFICE | | |
| | | | | <i>[Signature]</i> | <i>[Signature]</i> | | |
| | | | | APPROVED U.S. ARMY ARMAMENT, MUNITIONS AND CHEMICAL COMMAND | | | |
| | | | | <i>[Signature]</i> DRSMC - TMD | | | |
| | | | | APPROVED BY ORDER OF COMMANDING GENERAL, U.S. ARMY MATERIEL DEVELOPMENT AND READINESS COMMAND (DARCOM) | | | |
| | | | | <i>[Signature]</i> U.S. ARMY DEFENSE AMMUNITION CENTER AND SCHOOL | | | |
| | | | | U. S. ARMY DARCOM DRAWING | | | |
| | | | | FEBRUARY 1984 | | | |
| | | | | CLASS | DIVISION | DRAWING | FILE |
| | | | | 19 | 48 | 4116/ 65H | 20PA 1002 |

GENERAL NOTES

- A. THIS APPENDIX CANNOT STAND ALONE BUT MUST BE USED IN CONJUNCTION WITH THE BASIC UNITIZATION PROCEDURES DRAWING 19-48-4116-20PA1002. TO PRODUCE AN APPROVED UNIT LOAD, ALL PERTINENT PROCEDURES, SPECIFICATIONS AND CRITERIA SET FORTH WITHIN THE BASIC DRAWING WILL APPLY TO THE PROCEDURES DELINEATED IN THIS APPENDIX. ANY EXCEPTIONS TO THE BASIC PROCEDURES ARE SPECIFIED IN THIS APPENDIX.
- B. DIMENSIONS, CUBE AND WEIGHT OF A PALLET UNIT WILL VARY SLIGHTLY DEPENDING UPON THE ACTUAL DIMENSIONS OF THE BOXES AND THE WEIGHT OF THE SPECIFIC ITEM BEING UNITIZED.
- C. THE LOAD STRAPS MAY BE THREADED THROUGH THE STRAP SLOTS OF A PALLET OR PRE-POSITIONED ON THE PALLET DECK PRIOR TO PLACING BOXES ON THE PALLET. LOAD STRAPS WILL BE TENSIONED AND SEALED PRIOR TO APPLICATION OF TIEDOWN STRAPS.
- D. INSTALL EACH TIEDOWN STRAP TO PASS UNDER THE TOP DECK BOARDS OF THE PALLET AND TO BE LOCATED AS SHOWN. TIEDOWN STRAPS WILL NOT BE APPLIED UNTIL THE LOAD STRAPS HAVE BEEN TENSIONED AND SEALED. NOTE: IF THE BOXES OF A PALLET UNIT DO NOT OVERHANG THE PALLET DECK SUFFICIENTLY TO ALLOW THE TIEDOWN STRAPS TO CONTACT THE BOXES IN THE BOTTOM LAYER OF THE UNIT, INSTALL EACH TIEDOWN STRAP TO ENIRCLE THE UNIT AND BE POSITIONED ON THE END CLEATS OF THE BOXES IN EACH STACK.
- E. THE FOLLOWING DARCOM DRAWINGS ARE APPLICABLE FOR OUTLOADING AND STORAGE OF THE ITEMS COVERED BY THIS APPENDIX.
 - CARLOADING ----- DRAWING 19-48-4115-5PA1002
 - TRUCKLOADING ----- DRAWING 19-48-4117-11PA1003
 - STORAGE ----- DRAWING 19-48-4118-1-2-3-4-14-22PA1002
- F. FOR METHOD OF SECURING A STRAP CUTTER TO THE PALLET UNIT, SEE DARCOM DRAWING 19-48-4127-20P1000.
- G. IF ITEMS COVERED HEREIN ARE UNITIZED PRIOR TO ISSUANCE OF THIS APPENDIX, THE BOXES NEED NOT BE REUNITIZED SOLELY TO CONFORM TO THIS APPENDIX.
- H. THE UNITIZATION PROCEDURES DEPICTED HEREIN MAY ALSO BE USED FOR UNITIZING GRENADES WHEN IDENTIFIED BY DIFFERENT NATIONAL STOCK NUMBERS (NSN) THAN WHAT IS SHOWN ON THE TITLE PAGE, PROVIDED THE BOX PACK DOES NOT VARY FROM WHAT IS DELINEATED HEREIN. THE EXPLOSIVE CLASSIFICATION OF OTHER ITEMS MAY BE DIFFERENT THAN WHAT IS SHOWN.
- J. WHEN THE UNIT LOAD DEPICTED AT LEFT IS TO BE USED FOR UNITIZING MARINE CORPS AMMUNITION, ONE LAYER OF BOXES MUST BE OMITTED, TIEDOWN STRAP LENGTHS MUST BE DECREASED TO 13'-3", AND LOAD STRAP LENGTHS MUST BE DECREASED TO 15'-6". THIS WILL RESULT IN AN OVERALL UNIT HEIGHT OF 43", A GROSS UNIT WEIGHT OF 1,781 POUNDS, AND A UNIT CUBE OF 43.1 CU FT. ADDITIONALLY, THE UNIT LOAD MAY BE MODIFIED AS DESCRIBED WHEN BEING SHIPPED BY MILVAN OR COMMERCIAL INTERMODAL FREIGHT CONTAINER, CONVENTIONAL VAN TRAILER OR CONVENTIONAL OR HIGH-CAPACITY BOXCAR. THE DETERMINATION TO REDUCE THE LOAD BY A LAYER FOR TRANSPORTATION WILL BE MADE BY THE RESPONSIBLE COMMAND AND WILL BE BASED UPON ECONOMICS OF TRANSPORTATION AND HANDLING.

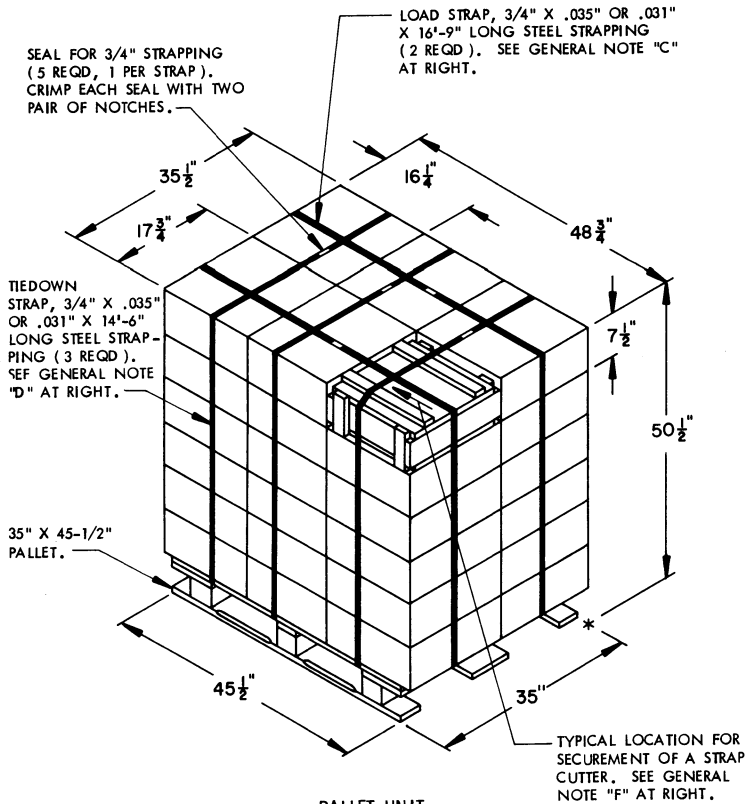

PALLET UNIT

SEE GENERAL NOTE "B" AT RIGHT.

| | |
|--|----------------------------|
| 36 BOXES OF HAND GRENADE (25 PER BOX) @ 57 LBS ----- | 2,052 LBS (APPROX) |
| DUNNAGE ----- | 6 LBS |
| PALLET ----- | 65 LBS |
| TOTAL WEIGHT ----- | 2,123 LBS (APPROX) |
| CUBE ----- | 50.6 CU FT (APPROX) |

BILL OF MATERIAL

| | | |
|-------------------------------|------------------|----------|
| PALLET, 35" X 45-1/2" ----- | 1 REQD ----- | 65 LBS |
| STEEL STRAPPING, 3/4" ----- | 77.00 REQD ----- | 5.50 LBS |
| SEAL FOR 3/4" STRAPPING ----- | 5 REQD ----- | NIL |

TIE PIECE, 1" X 4" X BOX WIDTH (2 REQD).
NAIL TO LONGITUDINAL PIECES W/2-6d
NAILS AT EACH END AND TO LATERAL PIECE
W/1-6d NAIL.

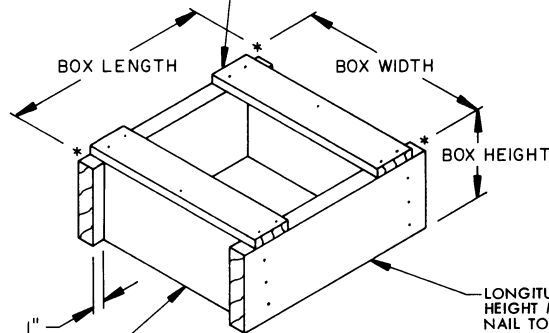

LATERAL PIECE, 2" X 8"
(RIPPED TO BOX HEIGHT
MINUS 3/4") X BOX WIDTH
MINUS 3" (2 REQD).

LONGITUDINAL PIECE, 2" X 8" (RIPPED TO BOX
HEIGHT MINUS 3/4") X BOX LENGTH (2 REQD).
NAIL TO LATERAL PIECES W/3-10d NAILS AT EACH
END.

FILLER ASSEMBLY

(FOR MINUS ONE BOX)