

APPENDIX 65E

UNITIZATION PROCEDURES FOR BOXED AMMUNITION AND COMPONENTS ON 4-WAY ENTRY PALLETS

GRENADE, HAND, FRAGMENTATION, PACKED 30
PER WOODEN BOX, UNITIZED 32 BOXES PER
35" X 45 $\frac{1}{2}$ " PALLET; APPROX BOX SIZE 19 $\frac{3}{4}$ " L
X 11 $\frac{3}{8}$ " W X 12 $\frac{3}{4}$ " H

PALLET UNIT DATA						
ITEMS INCLUDED		HAZARD CLASSIFICATION ^①				WEIGHT (LBS)
NSN	DODIC	DOT CLASS	CG CLASS	QD CLASS	COMP GROUP	
1330- 00-028-5839	G890	A	IV	(08) 1,1	F	1,768
00-782-5540	G889	A	IV	1,1	F	1,768
00-926-1857	G890	A	IV	(08) 1,1	F	1,672

NOTICE: THIS APPENDIX CANNOT STAND ALONE BUT MUST BE USED IN CONJUNCTION WITH THE BASIC UNITIZATION PROCEDURES DRAWING 19-48-4116-20PA1002.

^① HAZARD CLASSIFICATION DATA CONTAINED IN THE ABOVE CHART IS FOR GUIDANCE AND INFORMATIONAL PURPOSES ONLY. VERIFICATION OF THE SPECIFIED DATA SHOULD BE MADE BY CONSULTING THE MOST RECENT JOINT HAZARD CLASSIFICATION SYSTEM LISTING OR OTHER APPROVED LISTING(S).

DO NOT SCALE

REVISIONS			
	<small>DRAFTSMAN</small> <i>MBK</i>	<small>PROJ ENG</small> <i>MMW</i>	
	<small>CHECKER</small> <i>RSH</i>	<small>LOG ENGRG OFFICE</small> <i>John Boyd</i>	
	<small>APPROVED, U. S. ARMY ARMAMENT, MUNITIONS AND CHEMICAL COMMAND</small>		
	<i>Keith N. Benton</i> <small>DRSNC-LEP</small>	<i>Albin A.</i> <small>DRSNC-TND</small>	
	<small>APPROVED BY ORDER OF COMMANDING GENERAL, U. S. ARMY MATERIALS DEVELOPMENT AND READINESS COMMAND (DARCOM)</small>		
	<i>William A. Ernst</i> <small>U. S. ARMY DEFENSE AMMUNITION CENTER & SCHOOL</small>		
	U. S. ARMY DARCOM DRAWING		
	FEBRUARY 1984		
	<small>CLASS</small>	<small>DIVISION</small>	<small>DRAWING</small>
	19	48	4116/65E
			<small>FILE</small>
			20PA 1002

LOAD STRAP, 3/4" X .035" OR .031" X 17'-2" LONG STEEL STRAPPING (2 REQD). SEE GENERAL NOTE "C" AT RIGHT.

SEAL FOR 3/4" STRAPPING (6 REQD, 1 PER STRAP). CRIMP EACH SEAL WITH TWO PAIR OF NOTCHES.

TOP CLEATS ON THE BOXES IN THE OUTSIDE STACKS WILL BE TURNED INWARD, EXCEPT AS OTHERWISE SPECIFIED IN MIL-STD-129.

TIEDOWN STRAP, 3/4" X .035" OR .031" X 15'-3" LONG STEEL STRAPPING (4 REQD). SEE GENERAL NOTE "D" AT RIGHT.

35" X 45-1/2" PALLET.

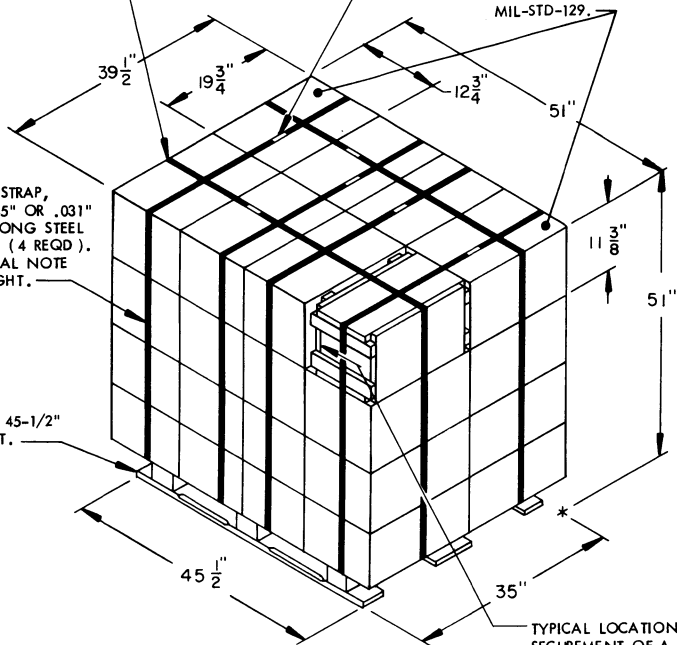

PALLET UNIT

SEE GENERAL NOTE "B" AT RIGHT.

TYPICAL LOCATION FOR SECUREMENT OF A STRAP CUTTER. SEE GENERAL NOTE "F" AT RIGHT.

GENERAL NOTES

- A. THIS APPENDIX CANNOT STAND ALONE BUT MUST BE USED IN CONJUNCTION WITH THE BASIC UNITIZATION PROCEDURES DRAWING 19-48-4116-20PA1002. TO PRODUCE AN APPROVED UNIT LOAD, ALL PERTINENT PROCEDURES, SPECIFICATIONS AND CRITERIA SET FORTH WITHIN THE BASIC DRAWING WILL APPLY TO THE PROCEDURES DELINEATED IN THIS APPENDIX. ANY EXCEPTIONS TO THE BASIC PROCEDURES ARE SPECIFIED IN THIS APPENDIX.
- B. DIMENSIONS, CUBE AND WEIGHT OF A PALLET UNIT WILL VARY SLIGHTLY DEPENDING UPON THE ACTUAL DIMENSIONS OF THE BOXES AND THE WEIGHT OF THE SPECIFIC ITEM BEING UNITIZED.
- C. THE LOAD STRAPS MAY BE THREADED THROUGH THE STRAP SLOTS OF A PALLET OR PRE-POSITIONED ON THE PALLET DECK PRIOR TO PLACING BOXES ON THE PALLET. LOAD STRAPS MUST BE TENSIONED AND SEALED PRIOR TO APPLICATION OF TIEDOWN STRAPS.
- D. INSTALL EACH TIEDOWN STRAP TO PASS UNDER THE DECK/ STRINGER BOARDS OF THE PALLET AND TO BE LOCATED AS SHOWN. TIEDOWN STRAPS WILL NOT BE APPLIED UNTIL THE LOAD STRAPS HAVE BEEN TENSIONED AND SEALED.
- E. THE FOLLOWING DARCOM DRAWINGS ARE APPLICABLE FOR OUTLOADING AND STORAGE OF THE ITEMS COVERED BY THIS APPENDIX.

CARLOADING -----	DRAWING 19-48-4115-5PA1002
TRUCKLOADING -----	DRAWING 19-48-4117-11PA1003
STORAGE -----	DRAWING 19-48-4118-1-2-3-4-14-22 PA1002
- F. FOR METHOD OF SECURING A STRAP CUTTER TO THE PALLET UNIT, SEE DARCOM DRAWING 19-48-4127-20P1000.
- G. IF ITEMS COVERED HEREIN ARE UNITIZED PRIOR TO ISSUANCE OF THIS APPENDIX, THE BOXES NEED NOT BE REUNITIZED SOLELY TO CONFORM TO THIS APPENDIX.
- H. THE UNITIZATION PROCEDURES DEPICTED HEREIN MAY ALSO BE USED FOR UNITIZING HAND GRENADES WHEN IDENTIFIED BY DIFFERENT NATIONAL STOCK NUMBERS (NSN) THAN WHAT IS SHOWN ON THE TITLE PAGE, PROVIDED THE BOX PACK DOES NOT VARY FROM WHAT IS DELINEATED HEREIN. THE EXPLOSIVE CLASSIFICATION OF OTHER ITEMS MAY BE DIFFERENT THAN WHAT IS SHOWN.

32 BOXES OF HAND GRENADES (30 PER BOX) @ 53 LBS -----	1,696 LBS (APPROX)
DUNNAGE -----	7 LBS
PALLET -----	65 LBS
TOTAL WEIGHT -----	1,768 LBS (APPROX)
CUBE -----	59.5 CU FT (APPROX)

BILL OF MATERIAL

PALLET, 35" X 45-1/2" -----	1 REQD	65 LBS
STEEL STRAPPING, 3/4" -----	95.33' REQD	6.81 LBS
SEAL FOR 3/4" STRAPPING -----	6 REQD	NIL

- J. WHEN THE UNIT LOAD DEPICTED AT LEFT IS TO BE USED FOR UNITIZING MARINE CORPS AMMUNITION, ONE LAYER OF BOXES MUST BE OMITTED, TIEDOWN STRAP LENGTHS MUST BE DECREASED TO 13'-5", AND LOAD STRAP LENGTHS MUST BE DECREASED TO 15'-4". THIS WILL RESULT IN AN OVERALL UNIT HEIGHT OF 39'-5/8", A GROSS UNIT WEIGHT OF 1,343 POUNDS, AND A UNIT CUBE OF 46.2 CUBIC FEET. ADDITIONALLY, THE UNIT LOAD MAY BE MODIFIED AS DESCRIBED WHEN BEING SHIPPED BY MILVAN OR COMMERCIAL INTERMODAL FREIGHT CONTAINER, CONVENTIONAL VAN TRAILER OR CONVENTIONAL OR HIGH-CAPACITY BOXCAR. THE DETERMINATION TO REDUCE THE LOAD BY A LAYER FOR TRANSPORTATION WILL BE MADE BY THE RESPONSIBLE COMMAND AND WILL BE BASED UPON ECONOMICS OF TRANSPORTATION AND HANDLING.
- K. THE 39-1/2" LENGTH DIMENSION IS AN EXCEPTION TO THE BASIC PROCEDURES. HOWEVER, THIS EXCEPTION IS NECESSARY FOR THE AMMUNITION PACK COVERED IN THIS APPENDIX TO MOST EFFECTIVELY GET AN ACCEPTABLE, COMPACT AND SOUND PALLET UNIT.

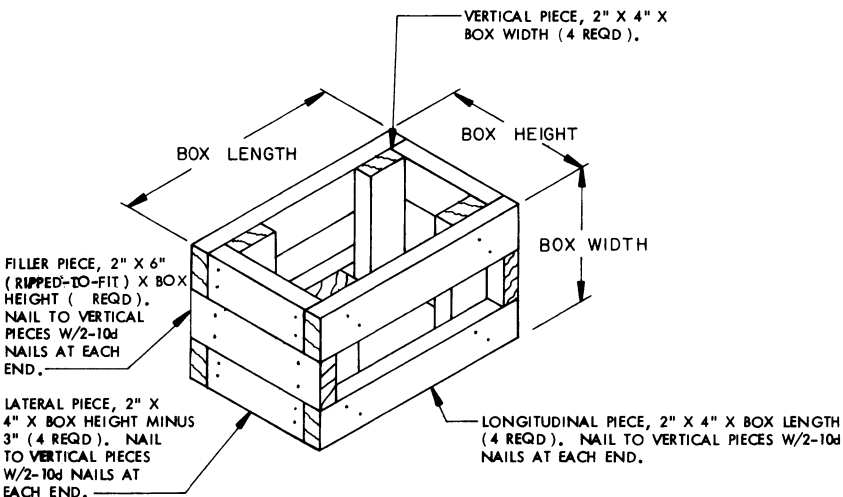

FILLER ASSEMBLY

(FOR MINUS ONE BOX)