

APPENDIX 65A

UNITIZATION PROCEDURES FOR BOXED AMMUNITION AND COMPONENTS ON 4-WAY ENTRY PALLETS

GRENADE, HAND, RIOT CONTROL TYPE, PACKED 16
PER WOODEN BOX, UNITIZED 45 BOXES PER 35" X
45-1/2" PALLET; APPROX BOX SIZE 15-3/8" L X
13-7/8" W X 8-1/8" H

NOTICE: THIS APPENDIX CANNOT STAND ALONE BUT MUST BE USED IN CONJUNCTION WITH
THE BASIC UNITIZATION PROCEDURES DRAWING 19-48-4116-20PA1002.

DISTRIBUTION STATEMENT A.

APPROVED FOR PUBLIC RELEASE;
DISTRIBUTION IS UNLIMITED.

U.S. ARMY MATERIEL COMMAND DRAWING				
APPROVED, U.S. ARMY ARMAMENT, MUNITIONS AND CHEMICAL COMMAND <i>NH</i> <i>David H. ...</i> SMCAR-ESK AMSMC-TJ	DRAFTSMAN	BETTY J. KUNDERT		
	ENGINEER	SANDRA M. SCHULTZ		
	SUPPLY ENGINEERING DIVISION	TRANSPORTATION ENGINEERING DIVISION	VALIDATION ENGINEERING DIVISION	
APPROVED BY ORDER OF COMMANDING GENERAL, U.S. ARMY MATERIEL COMMAND <i>John L. Byrd Jr</i>	LOGISTICS ENGINEERING OFFICE <i>William F Ernst</i>			
U.S. ARMY DEFENSE AMMUNITION CENTER AND SCHOOL	FEBRUARY 1984			
REVISION NO. 1	AUGUST 1994	CLASS	DIVISION	DRAWING
SEE THE REVISION LISTING ON PAGE 2	19	48	4116/ 65A	FILE 20PA 1002

DO NOT SCALE

PALLET UNIT DATA				
ITEMS INCLUDED		HAZARD CLASS AND DIVISION ●		APPROX WEIGHT LBS
NSN	DODIC	OD CLASS	COMP GROUP	
1330-				
00-182-1027	G963	1.4	G	1,422
00-799-8816	G963	1.4	G	1,422

● HAZARD CLASSIFICATION DATA CONTAINED IN THE ABOVE CHART IS FOR GUIDANCE AND INFORMATIONAL PURPOSES ONLY. VERIFICATION OF THE SPECIFIED DATA SHOULD BE MADE BY CONSULTING THE MOST RECENT JOINT HAZARD CLASSIFICATION SYSTEM LISTING OR OTHER APPROVED LISTING(S).

REVISION

REVISION NO. 1, DATED AUGUST 1984, CONSISTS OF:

1. DELETING ITEM BY NATIONAL STOCK NUMBER TO THE "PALLET UNIT DATA" CHART.

GENERAL NOTES

- A. THIS APPENDIX CANNOT STAND ALONE BUT MUST BE USED IN CONJUNCTION WITH THE BASIC UNITIZATION PROCEDURES DRAWING 19-48-4116-20PA1002. TO PRODUCE AN APPROVED UNIT LOAD, ALL PERTINENT PROCEDURES, SPECIFICATIONS AND CRITERIA SET FORTH WITHIN THE BASIC DRAWING WILL APPLY TO THE PROCEDURES DELINEATED IN THIS APPENDIX. ANY EXCEPTIONS TO THE BASIC PROCEDURES ARE SPECIFIED IN THIS APPENDIX.
- B. DIMENSIONS, CUBE AND WEIGHT OF A PALLET UNIT WILL VARY SLIGHTLY DEPENDING UPON THE ACTUAL DIMENSIONS OF THE BOXES AND THE WEIGHT OF THE SPECIFIC ITEM BEING UNITIZED.
- C. THE LOAD STRAPS MAY BE THREADED THROUGH THE STRAP SLOTS OF A PALLET OR PRE-POSITIONED ON THE PALLET DECK PRIOR TO PLACING BOXES ON THE PALLET. LOAD STRAPS WILL NOT BE APPLIED UNTIL TIEDOWN STRAPS HAVE BEEN TENSIONED AND SEALED.
- D. INSTALL EACH TIEDOWN STRAP TO PASS UNDER THE TOP DECK BOARDS OF THE PALLET. TIEDOWN STRAPS MUST BE TENSIONED AND SEALED PRIOR TO APPLICATION OF LOAD STRAPS.
- E. THE FOLLOWING AMC DRAWINGS ARE APPLICABLE FOR UNLOADING AND STORAGE OF THE ITEMS COVERED BY THIS APPENDIX.
 - CARLOADING - - - - 19-48-4115-5PA1002
 - TRUCKLOADING - - - - 19-48-4117-11PA1003
 - STORAGE - - - - - 19-48-4118-1-2-3-4-14-22PA1002
 - COMMERCIAL CONTAINER - - - - - 19-48-4153-15PA1002
 - MILVAN - - - - - 19-48-4166-15PA1003
 - SIDE OPENING COMMERCIAL CONTAINER - - - - - 19-48-4267-15PA1009
- F. FOR METHOD OF SECURING A STRAP CUTTER TO THE PALLET UNIT, SEE AMC DRAWING 19-48-4127-20P1000.
- G. IF ITEMS COVERED HEREIN ARE UNITIZED PRIOR TO ISSUANCE OF THIS APPENDIX, THE BOXES NEED NOT BE REUNITIZED SOLELY TO CONFORM TO THIS APPENDIX.
- H. THE UNITIZATION PROCEDURES DEPICTED HEREIN MAY ALSO BE USED FOR UNITIZING HAND GRENADES WHEN IDENTIFIED BY DIFFERENT NATIONAL STOCK NUMBERS (NSN) THAN WHAT IS SHOWN ON PAGE 2, PROVIDED THE BOX PACK DOES NOT VARY FROM WHAT IS DELINEATED HEREIN. THE EXPLOSIVE CLASSIFICATION OF OTHER ITEMS MAY BE DIFFERENT THAN WHAT IS SHOWN.
- J. WHEN THE UNIT LOAD DEPICTED AT LEFT IS TO BE USED FOR UNITIZING MARINE CORPS AMMUNITION, ONE LAYER OF BOXES MUST BE OMITTED, TIEDOWN STRAP LENGTHS MUST BE DECREASED TO 13'-6", AND LOAD STRAP LENGTHS MUST BE DECREASED TO 14'-3". THIS WILL RESULT IN AN OVERALL UNIT HEIGHT OF 38", A GROSS UNIT WEIGHT OF 1,152 POUNDS, AND A UNIT CUBE OF 42.2 CUBIC FEET. ADDITIONALLY, THE UNIT MAY BE MODIFIED AS DESCRIBED WHEN BEING SHIPPED BY MILVAN OR COMMERCIAL INTERMODAL FREIGHT CONTAINER. THE DETERMINATION TO REDUCE THE LOAD BY A LAYER FOR TRANSPORTATION WILL BE MADE BY THE RESPONSIBLE COMMAND AND WILL BE BASED UPON ECONOMICS OF TRANSPORTATION AND HANDLING.
- K. THE 41-5/8" LENGTH DIMENSION OF THE UNIT DEPICTED AT LEFT IS AN EXCEPTION TO THE BASIC PROCEDURES. HOWEVER, THE EXCEPTION IS NECESSARY FOR THE AMMUNITION PACK COVERED BY THIS APPENDIX TO MOST EFFECTIVELY GET AN ACCEPTABLE, COMPACT AND SOUND PALLET UNIT.
- L. THE STYLE 1A PALLET DELINEATED IN THE DETAIL AT LEFT NEED NOT HAVE CHAMFERS OR STRAP SLOTS AS SPECIFIED WITHIN MILITARY SPECIFICATION MIL-P-15011 WHEN USED FOR THE UNITIZATION OF ITEMS COVERED BY THIS APPENDIX.

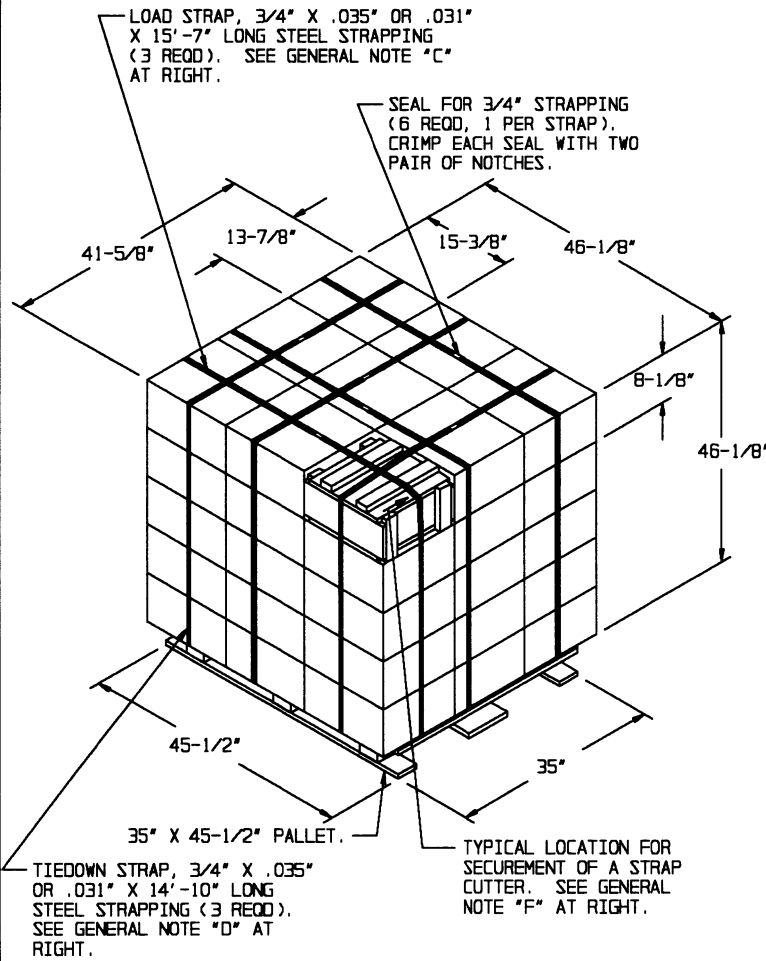

PALLET UNIT

SEE GENERAL NOTE "B" AT RIGHT.

45 BOXES OF HAND GRENADE (16 PER BOX) AT 30 LBS	-----	1,350 LBS (APPROX)
DUNNAGE	-----	7 LBS
PALLET	-----	65 LBS
<hr/>		
TOTAL WEIGHT	-----	1,422 LBS (APPROX)
CUBE	-----	51.3 CU FT (APPROX)

BILL OF MATERIAL

PALLET, 35" X 45-1/2"	---	1 REQD	-----	65 LBS	
STEEL STRAPPING, 3/4"	---	91.25'	REQD	-----	6.52 LBS
SEAL FOR 3/4" STRAPPING	---	6 REQD	-----	NIL	

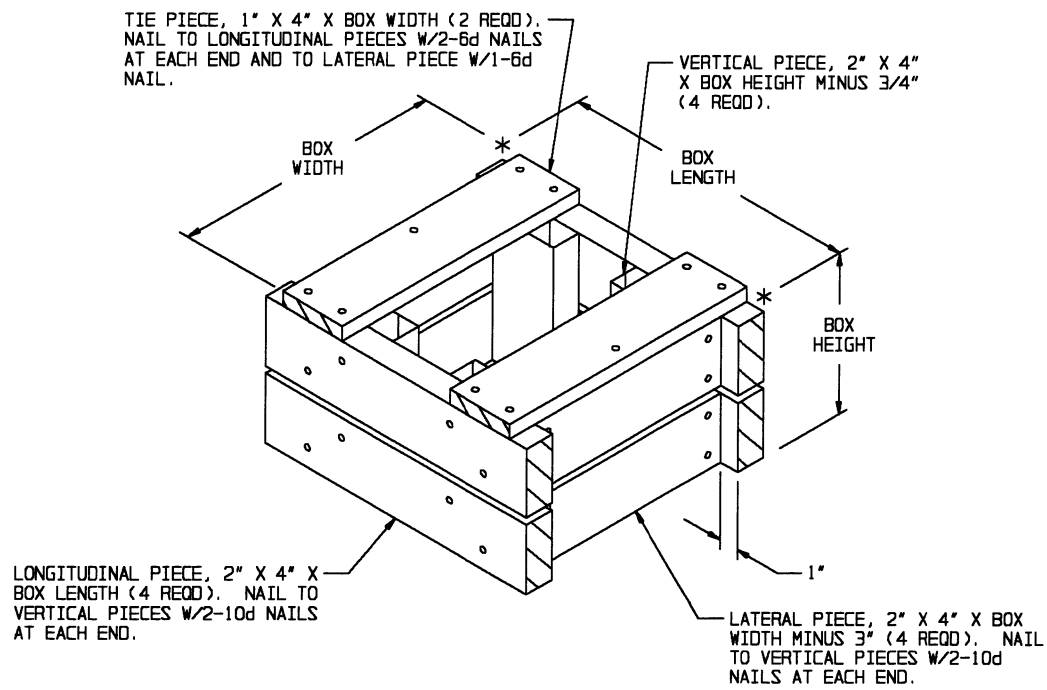

FILLER ASSEMBLY
(FOR MINUS ONE BOX)