

APPENDIX 55

UNITIZATION PROCEDURES FOR BOXED AMMUNITION AND COMPONENTS ON 4-WAY ENTRY PALLETS

FUZE, BOMB, TAIL, PACKED 15 PER WOODEN BOX,
UNITIZED 16 BOXES PER 35" X 45 $\frac{1}{2}$ " PALLET; APPROX
BOX SIZE 22 $\frac{15}{16}$ " L X 9 $\frac{11}{16}$ " W X 14 $\frac{7}{32}$ " H

PALLET UNIT DATA						
ITEMS INCLUDED		HAZARD CLASSIFICATION				WEIGHT
NSN	DODIC	DOT CLASS	CG CLASS	QD CLASS	COMP GROUP	(LBS)
1325-00 756-2184	F989	C	III	(04)1.2	B	698

NOTICE: THIS APPENDIX CANNOT STAND ALONE BUT MUST BE
USED IN CONJUNCTION WITH THE BASIC UNITIZATION
PROCEDURES DRAWING 19-48-4116-20PA1002.

REVISIONS				DRAFTSMAN <i>SR</i>	PROJ. ENG. <i>GBF/new</i>
				CHECKER <i>RSK/2087</i>	LOC. ENG'G OFFICE <i>John Bond</i>
APPROVED, U. S. ARMY ARMAMENT MATERIEL READINESS COMMAND					
			<i>Patricia S. Calverley</i>		
			<i>Donnell C. Fetter</i>		
			DRSAR-MAD	DRSAR-TMO	
APPROVED BY ORDER OF COMMANDING GENERAL, U. S. ARMY MATERIEL DEVELOPMENT AND READINESS COMMAND (DARCOM)					
<i>John X. Boyd Jr.</i>					
U. S. ARMY DEFENSE AMMUNITION CENTER AND SCHOOL					
U. S. ARMY DARCOM DRAWING					
NOVEMBER 1980					
CLASS	DIVISION	DRAWING	FILE		
19	48	4116/55	20PA 1002		

DO NOT SCALE

GENERAL NOTES

- A. THIS APPENDIX CANNOT STAND ALONE BUT MUST BE USED IN CONJUNCTION WITH THE BASIC UNITIZATION PROCEDURES DRAWING 19-48-4116-20PA1002. TO PRODUCE AN APPROVED UNIT LOAD, ALL PERTINENT PROCEDURES, SPECIFICATIONS AND CRITERIA SET FORTH WITHIN THE BASIC DRAWING WILL APPLY TO THE PROCEDURES DELINEATED IN THIS APPENDIX. ANY EXCEPTIONS TO THE BASIC PROCEDURES ARE SPECIFIED IN THIS APPENDIX.
- B. DIMENSIONS, CUBE AND WEIGHT OF A PALLET UNIT WILL VARY SLIGHTLY DEPENDING UPON THE ACTUAL DIMENSIONS OF THE BOXES AND THE WEIGHT OF THE SPECIFIC ITEM BEING UNITIZED.
- C. INSTALL EACH HORIZONTAL STRAP TO ENCIRCLE EACH LAYER OF BOXES ON THE PALLET. HORIZONTAL STRAPS MUST BE TENSIONED AND SEALED PRIOR TO APPLICATION OF TIEDOWN STRAPS.
- D. INSTALL EACH TIEDOWN STRAP TO PASS UNDER THE TOP DECK BOARDS OF THE PALLET AND TO BE LOCATED AS SHOWN. TIEDOWN STRAPS WILL NOT BE APPLIED UNTIL THE HORIZONTAL STRAPS HAVE BEEN TENSIONED AND SEALED.
- E. THE FOLLOWING DARCOM DRAWINGS ARE APPLICABLE FOR OUTLOADING AND STORAGE OF THE ITEMS COVERED BY THIS APPENDIX.
 - CARLOADING ----- DRAWING 19-48-4115-5PA1002
 - TRUCKLOADING ----- DRAWING 19-48-4117-11PA1003
 - STORAGE ----- DRAWING 19-48-4118-1-2-14-22PA1002
- F. FOR METHOD OF SECURING A STRAP CUTTER TO THE PALLET UNIT, SEE DARCOM DRAWING 19-48-4127-20P1000.
- G. IF ITEMS COVERED HEREIN ARE UNITIZED PRIOR TO ISSUANCE OF THIS APPENDIX, THE BOXES NEED NOT BE REUNITIZED SOLELY TO CONFORM TO THIS APPENDIX.
- H. THE UNITIZATION PROCEDURES DEPICTED HEREIN MAY ALSO BE USED FOR UNITIZING FUZES WHEN IDENTIFIED BY DIFFERENT NATIONAL STOCK NUMBERS (NSN) THAN WHAT IS SHOWN ON THE TITLE PAGE, PROVIDED THE BOX PACK DOES NOT VARY FROM WHAT IS DELINEATED HEREIN. THE EXPLOSIVE CLASSIFICATION OF OTHER ITEMS MAY BE DIFFERENT THAN WHAT IS SHOWN.

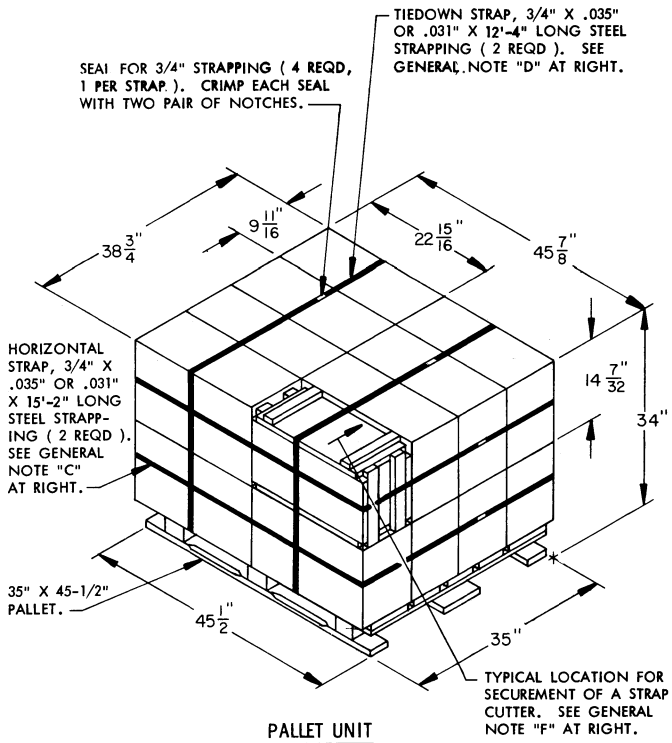

SEE GENERAL NOTE "B" AT RIGHT.

16 BOXES OF FUZE, BOMB, TAIL (15 PER BOX) @ 39.3 LBS -----	629 LBS (APPROX)
DUNNAGE -----	4 LBS
PALLET -----	65 LBS
TOTAL WEIGHT -----	698 LBS (APPROX)
CUBE -----	35.0 CU FT (APPROX)

BILL OF MATERIAL			
PALLET, 35" X 45-1/2" -----	1 REQD -----	65 LBS	
STEEL STRAPPING, 3/4" -----	55.00' REQD -----	3.93 LBS	
SEAL FOR 3/4" STRAPPING -----	4 REQD -----	NIL	

