

APPENDIX 54A

UNITIZATION PROCEDURES FOR BOXED AMMUNITION AND COMPONENTS ON 4-WAY ENTRY PALLETS

LUG, BOMB SUSPENSION, PACKED VARIOUS QUANTITIES
PER WOODEN BOX, UNITIZED 80 BOXES PER 40" X 48"
PALLET; APPROX BOX SIZE $10\frac{1}{8}$ " L X $10\frac{1}{4}$ " W X 9" H

PALLET UNIT DATA						
ITEMS INCLUDED		HAZARD CLASSIFICATION				WEIGHT (LBS)
NSN	DODIC	DOT CLASS	CG CLASS	QD CLASS	COMP GROUP	
1325- 00-684-1364	G273	—	—	—	—	1,130

NOTICE: THIS APPENDIX CANNOT STAND ALONE BUT MUST
BE USED IN CONJUNCTION WITH THE BASIC UNITIZATION
PROCEDURES DRAWING 19-48-4116-20PA1002.

REVISIONS				DESIGNED <i>WRF/llw</i>	PROJ ENG <i>WRF/llw</i>
				CHECKED <i>GRG</i>	LOG BOOK OFFICE <i>W. F. Coyle</i>
APPROVED, U. S. ARMY ARMAMENT MATERIEL READINESS COMMAND				<i>J. Martin</i> <i>Leo Orrell</i> <small>DREAR - LEP DREAR - TCM</small>	
APPROVED BY ORDER OF COMMANDING GENERAL, U. S. ARMY MATERIEL DEVELOPMENT AND READINESS COMMAND (MARCOS)				<i>John A. Reynolds</i> <small>U. S. ARMY DEFENSE ACQUISITION CENTER AND SCHOOL</small>	
U. S. ARMY DARCOM DRAWING					
NOVEMBER 1981					
CLASS	DIVISION	DRAWING	FILE		
19	48	4116/ 54A	20PA 1002		

DO NOT SCALE

GENERAL NOTES

- A. THIS APPENDIX CANNOT STAND ALONE BUT MUST BE USED IN CONJUNCTION WITH THE BASIC UNITIZATION PROCEDURES DRAWING 19-48-4116-20PA1002. TO PRODUCE AN APPROVED UNIT LOAD, ALL PERTINENT PROCEDURES, SPECIFICATIONS AND CRITERIA SET FORTH WITHIN THE BASIC DRAWING WILL APPLY TO THE PROCEDURES DELINEATED IN THIS APPENDIX. ANY EXCEPTIONS TO THE BASIC PROCEDURES ARE SPECIFIED IN THIS APPENDIX.
- B. DIMENSIONS, CUBE AND WEIGHT OF A PALLET UNIT WILL VARY SLIGHTLY DEPENDING UPON THE ACTUAL DIMENSIONS OF THE BOXES AND THE WEIGHT OF THE SPECIFIC ITEM BEING UNITIZED.
- C. THE LOAD STRAPS MUST BE PRE-POSITIONED ON THE PALLET DECK PRIOR TO PLACING BOXES ON THE PALLET. LOAD STRAPS MUST BE TENSIONED AND SEALED PRIOR TO APPLICATION OF TIEDOWN STRAPS.
- D. INSTALL EACH TIEDOWN STRAP TO PASS UNDER THE TOP DECK/STRINGER BOARDS OF THE PALLET AND TO BE LOCATED AS SHOWN. TIEDOWN STRAPS WILL NOT BE APPLIED UNTIL THE LOAD STRAPS HAVE BEEN TENSIONED AND SEALED.
- E. THE FOLLOWING DARCOM DRAWINGS ARE APPLICABLE FOR OUT-LOADING AND STORAGE OF THE ITEMS COVERED BY THIS APPENDIX.
 CARLOADING-----DRAWING 19-48-4115-5PA1002.
 TRUCKLOADING-----DRAWING 19-48-4117-11PA1003.
 STORAGE-----DRAWING 19-48-4118-1-2-3-4-14-22PA1002.
- F. FOR METHOD OF SECURING A STRAP CUTTER TO THE PALLET UNIT, SEE DARCOM DRAWING 19-48-4127-20P1000.
- G. IF ITEMS COVERED HEREIN ARE UNITIZED PRIOR TO ISSUANCE OF THIS APPENDIX, THE BOXES NEED NOT BE REUNITIZED SOLELY TO CONFORM TO THIS APPENDIX.
- H. THE UNITIZATION PROCEDURES DEPICTED HEREIN MAY ALSO BE USED FOR UNITIZING LUG, BOMB SUSPENSION WHEN IDENTIFIED BY DIFFERENT NATIONAL STOCK NUMBERS (NSN) THAN WHAT IS SHOWN ON THE TITLE PAGE, PROVIDED THE BOX PACK DOES NOT VARY FROM WHAT IS DELINEATED HEREIN. THE EXPLOSIVE CLASSIFICATION OF OTHER ITEMS MAY BE DIFFERENT THAN WHAT IS SHOWN.

LOAD STRAP, 3/4" X .035" OR .031" X 15'-7"
 LONG STEEL STRAPPING (4 REQD). SEE
 GENERAL NOTE "C" AT RIGHT.

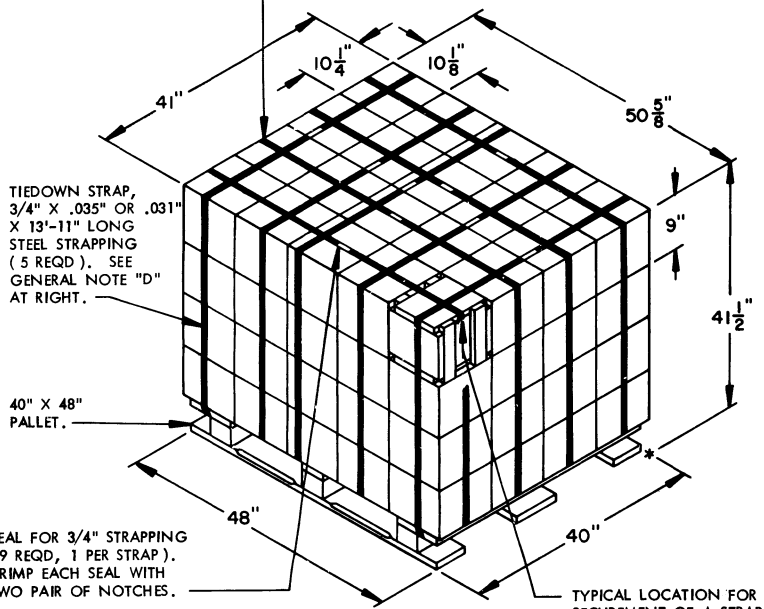

PALLET UNIT

SEE GENERAL NOTE "B" AT RIGHT.

80 BOXES OF LUGS (VARIOUS QUANTITIES PER BOX) @ 13 LBS-----1,040 LBS (APPROX)
 DUNNAGE-----10 LBS
 PALLET-----80 LBS

TOTAL WEIGHT-----1,130 LBS (APPROX)
 CUBE-----49.8 CU FT (APPROX)

BILL OF MATERIAL

PALLET, 40" X 48"-----	1 REQD-----	80 LBS
STEEL STRAPPING, 3/4"-----	131.92' REQD-----	9.42 LBS
SEAL FOR 3/4" STRAPPING-----	9 REQD-----	NIL

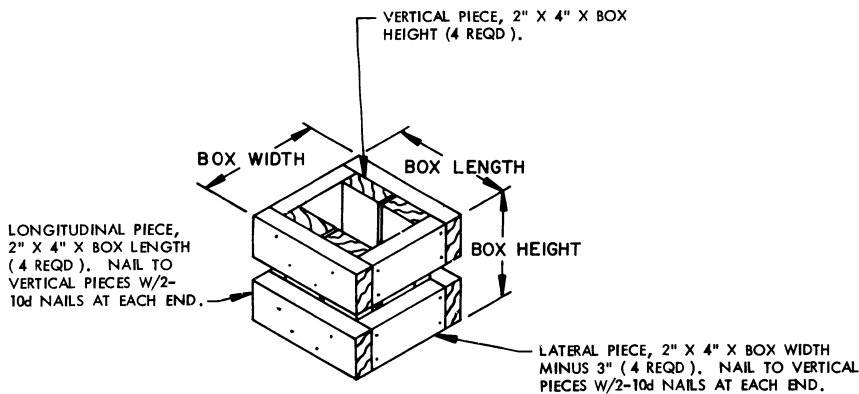

FILLER ASSEMBLY

(FOR MINUS ONE BOX)