

APPENDIX 5IA

UNITIZATION PROCEDURES FOR BOXED AMMUNITION AND COMPONENTS ON 4-WAY ENTRY PALLETS

ADAPTER-BOOSTER, BOMB, PACKED 30 PER WOODEN
BOX, UNITIZED 12 BOXES PER 40" X 48" PALLET;
APPROX BOX SIZE 24" L X 20 $\frac{1}{4}$ " W X 14 $\frac{1}{2}$ " H

PALLET UNIT DATA						
ITEMS INCLUDED		HAZARD CLASSIFICATION ①				WEIGHT (LBS)
NSN	DOD IC	DOT CLASS	CG CLASS	QD CLASS	COMP GROUP	
1325- 00-926-3954 00-935-2070	F372	A	X-A	1.1	D	1,633
	F387	A	X-A	1.1	D	1,633

REVISION

REVISION NO. 1, DATED MARCH 1985, CONSISTS OF:

1. CHANGING QUANTITY PER BOX.
2. CHANGING BOX WEIGHT.
3. UPDATING DRAWING TO CONFORM TO 1 AND 2.

NOTICE: THIS APPENDIX CANNOT STAND ALONE BUT MUST
BE USED IN CONJUNCTION WITH THE BASIC UNITIZATION
PROCEDURES DRAWING 19-48-4116-20PA1002.

① HAZARD CLASSIFICATION DATA CONTAINED IN THE ABOVE CHART IS FOR GUIDANCE AND INFORMATIONAL PURPOSES ONLY. VERIFICATION OF THE SPECIFIED DATA SHOULD BE MADE BY CONSULTING THE MOST RECENT JOINT HAZARD CLASSIFICATION SYSTEM LISTING OR OTHER APPROVED LISTING(S).

DO NOT SCALE

REVISIONS				DATE	BY	APPROVED	TITLE
1	MAR 85	WRE WRE	John Lopez	GPG	WRE	GPG	GPG
				APPROVED, U. S. ARMY ARMAMENT MATERIAL READINESS COMMAND			
				W. H. Benton / Darrell C. Fettes			
				APPROVED BY ORDER OF COMMANDING GENERAL, U. S. ARMY MATERIAL DEVELOPMENT AND READINESS COMMAND (MARCOS)			
				John L. Byrd Jr.			
				U. S. ARMY DEFENSE ACQUISITION CENTER AND SCHOOL			
U. S. ARMY DARCOM DRAWING							
DECEMBER 1980							
CLASS	DIVISION	DRAWING	FILE				
19	48	4116/ 51A	20PA 1002				

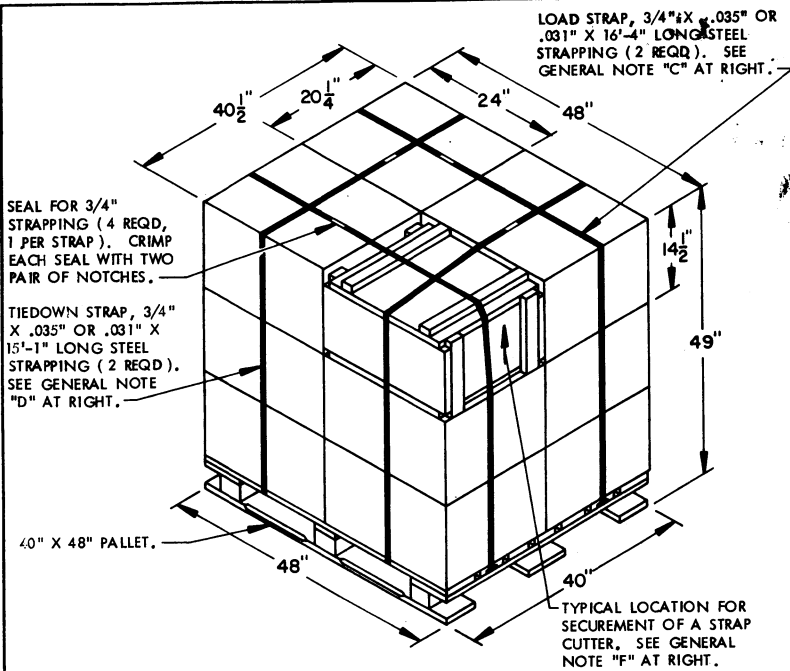

GENERAL NOTES

- A. THIS APPENDIX CANNOT STAND ALONE BUT MUST BE USED IN CONJUNCTION WITH THE BASIC UNITIZATION PROCEDURES DRAWING 19-48-4116-20PA1002. TO PRODUCE AN APPROVED UNIT LOAD, ALL PERTINENT PROCEDURES, SPECIFICATIONS AND CRITERIA SET FORTH WITHIN THE BASIC DRAWING WILL APPLY TO THE PROCEDURES DELINEATED IN THIS APPENDIX. ANY EXCEPTIONS TO THE BASIC PROCEDURES ARE SPECIFIED IN THIS APPENDIX.
- B. DIMENSIONS, CUBE AND WEIGHT OF A PALLET UNIT WILL VARY SLIGHTLY DEPENDING UPON THE ACTUAL DIMENSIONS OF THE BOXES AND THE WEIGHT OF THE SPECIFIC ITEM BEING UNITIZED.
- C. THE LOAD STRAPS WILL BE THREADED THROUGH THE STRAP SLOTS OF A PALLET.
- D. INSTALL EACH TIEDOWN STRAP TO PASS UNDER THE TOP DECK BOARDS OF THE PALLET AND TO BE LOCATED AS SHOWN. TIEDOWN STRAPS WILL BE TENSIONED AND SEALED PRIOR TO LOAD STRAPS.
- E. THE FOLLOWING AMC (DARCOM) DRAWINGS ARE APPLICABLE FOR OUTLOADING AND STORAGE OF THE ITEMS COVERED BY THIS APPENDIX.
 - CARLOADING ----- DRAWING 19-48-4115-5PA1002
 - TRUCKLOADING ----- DRAWING 19-48-4117-11PA1003
 - STORAGE ----- DRAWING 19-48-4118-1-2-14-22PA1002
- F. FOR METHOD OF SECURING A STRAP CUTTER TO THE PALLET UNIT, SEE DARCOM DRAWING 19-48-4127-20P1000.
- G. IF ITEMS COVERED HEREIN ARE UNITIZED PRIOR TO ISSUANCE OF THIS APPENDIX, THE BOXES NEED NOT BE REUNITIZED SOLELY TO CONFORM TO THIS APPENDIX.
- H. THE UNITIZATION PROCEDURES DEPICTED HEREIN MAY ALSO BE USED FOR UNITIZING ADAPTERS WHEN IDENTIFIED BY DIFFERENT NATIONAL STOCK NUMBERS (NSN) THAN WHAT IS SHOWN ON THE TITLE PAGE, PROVIDED THE BOX PACK DOES NOT VARY FROM WHAT IS DELINEATED HEREIN. THE EXPLOSIVE CLASSIFICATION OF OTHER ITEMS MAY BE DIFFERENT THAN WHAT IS SHOWN.

PALLET UNIT

SEE GENERAL NOTE "B" AT RIGHT.

12 BOXES OF BOMB BOOSTER ADAPTER (30 PER BOX) @ 129 LBS -----	1,548 LBS (APPROX)
DUNNAGE -----	5 LBS
PALLET -----	80 LBS
<hr/>	
TOTAL WEIGHT -----	1,633 LBS (APPROX)
CUBE -----	55.1 CU FT (APPROX)

BILL OF MATERIAL

PALLET, 40" X 48" -----	1 REQD -----	80 LBS
STEEL STRAPPING, 3/4" -----	62.83 REQD -----	4.49 LBS
SEAL FOR 3/4" STRAPPING -----	4 REQD -----	NIL

