

# APPENDIX 5I

## UNITIZATION PROCEDURES FOR BOXED AMMUNITION AND COMPONENTS ON 4-WAY ENTRY PALLETS

ADAPTER-BOOSTER, BOMB, PACKED 20 PER  
WOODEN BOX, UNITIZED 16 BOXES PER 40" X 48"  
PALLET; APPROX BOX SIZE 32" L X 13 $\frac{1}{4}$ " W X 10 $\frac{3}{4}$ " H

PALLET UNIT DATA						
ITEMS INCLUDED		HAZARD CLASSIFICATION <sup>①</sup>				WEIGHT
NSN	DODIC	DOT CLASS	CG CLASS	QD CLASS	COMP GROUP	( LBS )
1325- 00-386-2434	F370	C	I	1.4	C	1,686
01-041-8493	F364	C	I	1.4	C	1,686

① HAZARD CLASSIFICATION DATA CONTAINED IN THE ABOVE CHART IS FOR GUIDANCE AND INFORMATIONAL PURPOSES ONLY. VERIFICATION OF THE SPECIFIED DATA SHOULD BE MADE BY CONSULTING THE MOST RECENT JOINT HAZARD CLASSIFICATION SYSTEM LISTING OR OTHER APPROVED LISTING ( S ).

NOTICE: THIS APPENDIX CANNOT STAND ALONE BUT MUST BE USED IN CONJUNCTION WITH THE BASIC UNITIZATION PROCEDURES DRAWING 19-48-4116-20PA1002.

### REVISION

REVISION NO. 1, DATED AUGUST 1981, CONSISTS OF:

1. ADDING NATIONAL STOCK NUMBER TO "PALLET UNIT DATA" CHART.
2. UPDATING STORAGE DRAWING NUMBER.

REVISION NO. 2, DATED MAY 1986, CONSISTS OF:

UPDATING "PALLET UNIT DATA" CHART.

**DO NOT SCALE**

REVISIONS				REVISIONS	FIELD USE	MTR (R2)
NO.	DATE	BY	FOR	P.D.	WRE/SES	MTR (R2)
1	AUG 81	WRF/WFE	B. H. Hinton	R.S.W.	Newville	
2	MAY 86	WRF/WFE	John L. Boyd	B. H. Hinton	D. C. Feltner	
				U. S. ARMY DARCOM DRAWING		
				JUNE 1980		
				CLASS	DIVISION	DRAWING
				19	48	4116/5I
						FILE
						20PA 1002

TIEDOWN STRAP, 3/4" X .035" OR .031" X 13'-0" LONG STEEL STRAPPING (4 REQD). SEE GENERAL NOTE "D" AT RIGHT.

SEAL FOR 3/4" STRAPPING (5 REQD, 1 PER STRAP). CRIMP EACH SEAL WITH TWO PAIR OF NOTCHES.

HORIZONTAL STRAP, 3/4" X .035" OR .031" X 17'-0" LONG STEEL STRAPPING (1 REQD). SEE GENERAL NOTE "C" AT RIGHT.

TYPICAL LOCATION FOR SECUREMENT OF A STRAP CUTTER. SEE GENERAL NOTE "F" AT RIGHT.

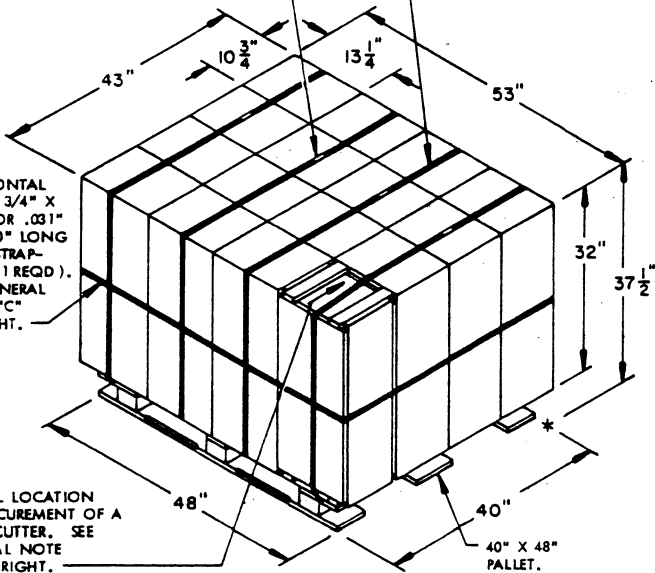

### PALLET UNIT

SEE GENERAL NOTE "B" AT RIGHT.

16 BOXES OF ADAPTERS (20 PER BOX) @ 100 LBS	-----	1,600 LBS (APPROX)
DUNNAGE	-----	6 LBS
PALLET	-----	80 LBS
<b>TOTAL WEIGHT</b>	-----	<b>1,686 LBS (APPROX)</b>
<b>CUBE</b>	-----	<b>49.5 CU FT (APPROX)</b>

### BILL OF MATERIAL

PALLET, 40" X 48"	-----	1 REQD	--- 20 LBS
STEEL STRAPPING, 3/4"	-----	71.33 REQD	--- 5.10 LBS
SEAL FOR 3/4" STRAPPING	-----	5 REQD	--- NIL

### GENERAL NOTES

- THIS APPENDIX CANNOT STAND ALONE BUT MUST BE USED IN CONJUNCTION WITH THE BASIC UNITIZATION PROCEDURES DRAWING 19-48-4116-20PA1002. TO PRODUCE AN APPROVED UNIT LOAD, ALL PERTINENT PROCEDURES, SPECIFICATIONS AND CRITERIA SET FORTH WITHIN THE BASIC DRAWING WILL APPLY TO THE PROCEDURES DELINEATED IN THIS APPENDIX. ANY EXCEPTIONS TO THE BASIC PROCEDURES ARE SPECIFIED IN THIS APPENDIX.
- DIMENSIONS, CUBE AND WEIGHT OF A PALLET UNIT WILL VARY SLIGHTLY DEPENDING UPON THE ACTUAL DIMENSIONS OF THE BOXES AND THE WEIGHT OF THE SPECIFIC ITEM BEING UNITIZED.
- INSTALL THE HORIZONTAL STRAP TO ENCIRCLE A LAYER OF BOXES ON THE PALLET. HORIZONTAL STRAP MUST BE TENSIONED AND SEALED PRIOR TO APPLICATION OF TIEDOWN STRAPS.
- INSTALL EACH TIEDOWN STRAP TO PASS UNDER THE DECK/STRINGER BOARDS OF THE PALLET AND TO BE LOCATED AS SHOWN. TIEDOWN STRAPS WILL NOT BE APPLIED UNTIL THE HORIZONTAL STRAP HAS BEEN TENSIONED AND SEALED.
- THE FOLLOWING AMC (DARCOM) DRAWINGS ARE APPLICABLE FOR UNLOADING AND STORAGE OF THE ITEMS COVERED BY THIS APPENDIX.
 

CARLOADING	-----	DRAWING 19-48-4115-5PA1002
TRUCKLOADING	-----	DRAWING 19-48-4117-11PA1003
STORAGE	-----	DRAWING 19-48-4118-1-2-3-4-14-22PA1002
- FOR METHOD OF SECURING A STRAP CUTTER TO THE PALLET UNIT, SEE DARCOM DRAWING 19-48-4127-20P1000.
- IF ITEMS COVERED HEREIN ARE UNITIZED PRIOR TO ISSUANCE OF THIS APPENDIX, THE BOXES NEED NOT BE REUNITIZED SOLELY TO CONFORM TO THIS APPENDIX.
- THE UNITIZATION PROCEDURES DEPICTED HEREIN MAY ALSO BE USED FOR UNITIZING ADAPTERS WHEN IDENTIFIED BY DIFFERENT NATIONAL STOCK NUMBERS (NSN) THAN WHAT IS SHOWN ON THE TITLE PAGE, PROVIDED THE BOX PACK DOES NOT VARY FROM WHAT IS DELINEATED HEREIN. THE EXPLOSIVE CLASSIFICATION OF OTHER ITEMS MAY BE DIFFERENT THAN WHAT IS SHOWN.

TIE PIECE, 1" X 4" X BOX HEIGHT (2 REQD). NAIL TO LONGITUDINAL PIECES W/2-6d NAILS AT EACH END AND TO LATERAL PIECES W/1-6d NAIL.

LATERAL PIECE, 2" X 4" X BOX HEIGHT MINUS 3" (4 REQD). NAIL TO THE VERTICAL PIECES W/2-10d NAILS AT EACH END.

VERTICAL PIECE, 2" X 4" X BOX LENGTH MINUS 3/4" (4 REQD).

LONGITUDINAL PIECE, 2" X 4" X BOX WIDTH (4 REQD). NAIL TO VERTICAL PIECES W/2-10d NAILS AT EACH END.

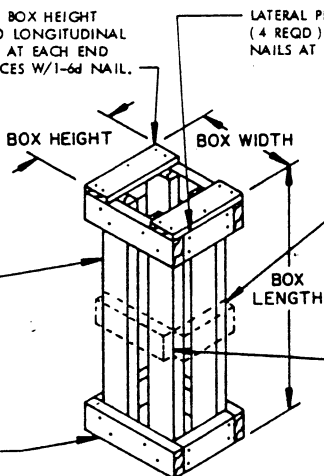

STRAP BEARING PIECE, 2" X 4" BY BOX HEIGHT MINUS 3" (AS REQD). NAIL TO VERTICAL PIECES W/2-10d NAILS AT EACH END. NOTE: WHEN A UNIT HAS MORE THAN FOUR (4) BOXES OMITTED, THE FILLER ASSEMBLY OR ASSEMBLIES LOCATED IN AN OUTER STACK ON THE 40" SIDE OR SIDES OF THE PALLET WILL REQUIRE A "STRAP BEARING PIECE" UNDER THE HORIZONTAL STRAP. STAPLE STRAP TO "STRAP BEARING PIECE".

STRAP BEARING PIECE, 2" X 4" X BOX WIDTH MINUS 3" (AS REQD). NAIL TO THE VERTICAL PIECES W/2-10d NAILS AT EACH END. NOTE: WHEN A UNIT HAS MORE THAN EIGHT (8) BOXES OMITTED, THE FILLER ASSEMBLY OR ASSEMBLIES LOCATED IN AN OUTER STACK ON THE 48" SIDE OR SIDES OF THE PALLET UNIT WILL REQUIRE A "STRAP BEARING PIECE" POSITIONED UNDER THE HORIZONTAL STRAP. STAPLE STRAP TO THE "STRAP BEARING PIECE".

### FILLER ASSEMBLY

(FOR MINUS ONE BOX)