

APPENDIX 50B

UNITIZATION PROCEDURES FOR BOXED AMMUNITION AND COMPONENTS ON 4-WAY ENTRY PALLETS

**CANISTER, SMOKE, PACKED 30 PER WOODEN BOX,
UNITIZED 72 BOXES PER 35" X 45 $\frac{1}{2}$ " PALLET;
APPROX BOX SIZE 15 $\frac{19}{32}$ " L X 11 $\frac{13}{16}$ " W X 5 $\frac{7}{8}$ " H**

PALLET UNIT DATA						
ITEMS INCLUDED		HAZARD CLASSIFICATION [Ⓢ]				WEIGHT
NSN	DODIC	DOT CLASS	CG CLASS	QD CLASS	COMP GROUP	(LBS)
1320-01-122-5583	D455					1,872

NOTICE: THIS APPENDIX CANNOT STAND ALONE BUT MUST BE USED IN CONJUNCTION WITH UNITIZATION PROCEDURES DRAWING 19-48-4116-20PA1002

[Ⓢ]HAZARD CLASSIFICATION DATA CONTAINED IN THE ABOVE CHART IS FOR GUIDANCE AND INFORMATIONAL PURPOSES ONLY. VERIFICATION OF THE SPECIFIED DATA SHOULD BE MADE BY CONSULTING THE MOST RECENT JOINT HAZARD CLASSIFICATION SYSTEM LISTING OR OTHER APPROVED LISTING(S).

DO NOT SCALE

REVISIONS				DRAFTSMAN <i>MLC/rh</i>	PROJ ENG <i>rh</i>
				CHECKER <i>WKG</i>	LOG ENGRG OFFICE <i>W&B</i>
				APPROVED U.S. ARMY ARMAMENT, MUNITIONS AND CHEMICAL COMMAND <i>[Signature]</i>	
				DRBMC - LEA	DRBMC - TMO <i>H. Bannell</i>
				APPROVED BY ORDER OF COMMANDING GENERAL U.S. ARMY, MATERIEL DEVELOPMENT AND READINESS COMMAND (DARCOM) <i>John L. Byrd</i> U.S. ARMY DEFENSE AMMUNITION CENTER AND SCHOOL	
U. S. ARMY DARCOM DRAWING					
FEBRUARY 1984					
CLASS	DIVISION	DRAWING	FILE		
19	48	4116/50B	20PA1002		

GENERAL NOTES

- A. THIS APPENDIX CANNOT STAND ALONE BUT MUST BE USED IN CONJUNCTION WITH THE BASIC UNITIZATION PROCEDURES DRAWING 19-48-4116-20PA1002. TO PRODUCE AN APPROVED UNIT LOAD, ALL PERTINENT PROCEDURES, SPECIFICATIONS AND CRITERIA SET FORTH WITHIN THE BASIC DRAWING WILL APPLY TO THE PROCEDURES DELINEATED IN THIS APPENDIX. ANY EXCEPTIONS TO THE BASIC PROCEDURES ARE SPECIFIED IN THIS APPENDIX.
- B. DIMENSIONS, CUBE AND WEIGHT OF A PALLET UNIT WILL VARY SLIGHTLY DEPENDING UPON THE ACTUAL DIMENSIONS OF THE BOXES AND THE WEIGHT OF THE SPECIFIC ITEM BEING UNITIZED.
- C. THE LOAD STRAPS WILL BE PRE-POSITIONED ON THE PALLET DECK PRIOR TO PLACING BOXES ON THE PALLET.
- D. INSTALL EACH TIEDOWN STRAP TO PASS UNDER THE TOP DECK BOARDS OF THE PALLET AND TO BE LOCATED AS SHOWN. TIEDOWN STRAPS WILL BE TENSIONED AND SEALED PRIOR TO LOAD STRAPS.
- E. THE FOLLOWING DARCOM DRAWINGS ARE APPLICABLE FOR OUTLOADING AND STORAGE OF THE ITEMS COVERED BY THIS APPENDIX.
 CARLOADING-----DRAWING 19-48-4115-5PA1002
 TRUCKLOADING-----DRAWING 19-48-4117-11PA1003
 STORAGE-----DRAWING 19-48-4118-1-2-3-4-14-22PA1002
- F. FOR METHOD OF SECURING A STRAP CUTTER TO THE PALLET UNIT, SEE DARCOM DRAWING 19-48-4127-20P1000.
- G. IF ITEMS COVERED HEREIN ARE UNITIZED PRIOR TO ISSUANCE OF THIS APPENDIX, THE BOXES NEED NOT BE REUNITIZED SOLELY TO CONFORM TO THIS APPENDIX.
- H. THE UNITIZATION PROCEDURES DEPICTED HEREIN MAY ALSO BE USED FOR UNITIZING SMOKE CANISTERS WHEN IDENTIFIED BY DIFFERENT NATIONAL STOCK NUMBERS (NSN) THAN WHAT IS SHOWN ON THE TITLE PAGE, PROVIDED THE BOX PACK DOES NOT VARY FROM WHAT IS DELINEATED HEREIN. THE EXPLOSIVE CLASSIFICATION OF OTHER ITEMS MAY BE DIFFERENT THAN WHAT IS SHOWN.
- J. WHEN THE UNIT LOAD DEPICTED AT LEFT IS TO BE USED FOR UNITIZING MARINE CORPS AMMUNITION, TWO LAYERS OF BOXES MUST BE OMITTED, TIEDOWN STRAP LENGTHS MUST BE DECREASED TO 12'-10", AND LOAD STRAP LENGTHS MUST BE DECREASED TO 14'-9". THIS WILL RESULT IN AN OVERALL UNIT HEIGHT OF 40-3/4", A GROSS UNIT WEIGHT OF 1,422 POUNDS, AND A UNIT CUBE OF 39.1 CUBIC FEET. ADDITIONALLY, THE UNIT LOAD MAY BE MODIFIED AS DESCRIBED WHEN BEING SHIPPED BY MILVAN OR COMMERCIAL INTERMODAL FREIGHT CONTAINER, CONVENTIONAL VAN TRAILER OR CONVENTIONAL OR HIGH-CAPACITY BOXCAR. THE DETERMINATION TO REDUCE THE LOAD BY LAYER(S) FOR TRANSPORTATION WILL BE MADE BY THE RESPONSIBLE COMMAND AND WILL BE BASED UPON ECONOMICS OF TRANSPORTATION AND HANDLING

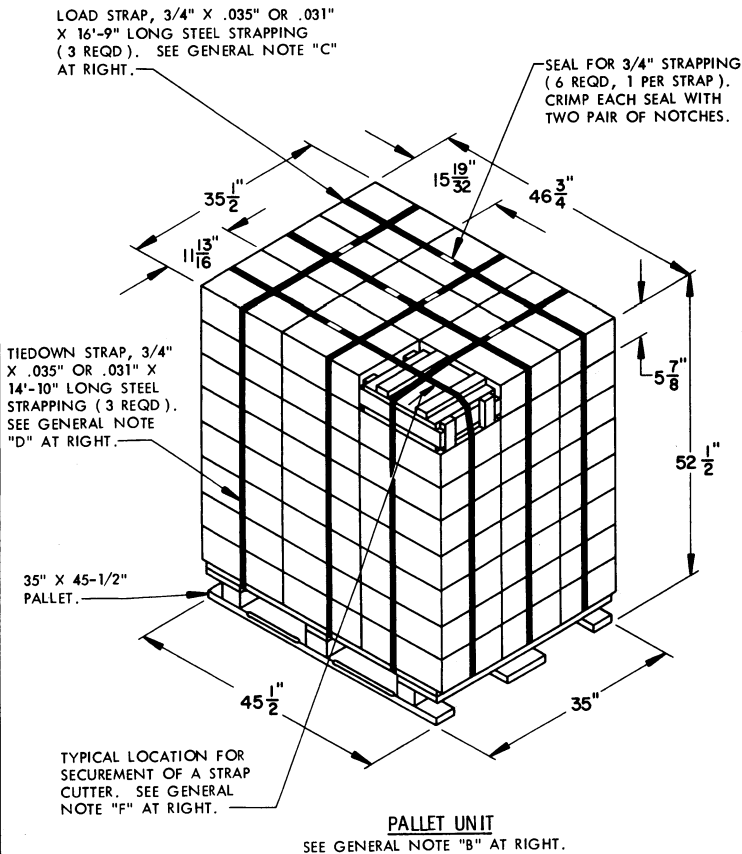

72 BOXES OF CANISTERS (30 PER BOX) @ 25 LBS-----	1,800 LBS (APPROX)
DUNNAGE-----	7 LBS
PALLET-----	65 LBS
TOTAL WEIGHT -----	1,872 LBS (APPROX)
CUBE -----	50.4 CU FT (APPROX)

BILL OF MATERIAL			
PALLET, 35" X 45-1/2"-----	1 REQD	-----	65 LBS
STEEL STRAPPING, 3/4"-----	94.75' REQD	-----	6.77 LBS
SEAL FOR 3/4" STRAPPING-----	6 REQD	-----	NIL

