

APPENDIX 50A

UNITIZATION PROCEDURES FOR BOXED AMMUNITION AND COMPONENTS ON 4-WAY ENTRY PALLETS

CANISTER, SMOKE, PACKED 24 PER WOODEN BOX,
UNITIZED 16 BOXES PER 40" X 48" PALLET;
APPROX BOX SIZE 21" L X 15" W X 12" H

PALLET UNIT DATA						
ITEMS INCLUDED		HAZARD CLASSIFICATION ^①				WEIGHT
NSN	DOD IC	DOT CLASS	CG CLASS	QD CLASS	COMP GROUP	(LBS)
1320-00-083-3890	D445	B	II - E	1.3	G	3,158
01-065-9832	D445	B	II - E	1.3	G	3,158
00-083-3891	D450	B	II - E	1.3	G	1,862
01-016-6794	D450	B	II - E	1.3	G	1,862
01-016-6795	D450	B	II - E	1.3	G	1,862

① HAZARD CLASSIFICATION DATA CONTAINED IN THE ABOVE CHART IS FOR GUIDANCE AND INFORMATIONAL PURPOSES ONLY. VERIFICATION OF THE SPECIFIED DATA SHOULD BE MADE BY CONSULTING THE MOST RECENT JOINT HAZARD CLASSIFICATION SYSTEM LISTING OR OTHER APPROVED LISTING(S).

NOTICE: THIS APPENDIX CANNOT STAND ALONE BUT MUST BE USED IN CONJUNCTION WITH THE BASIC UNITIZATION PROCEDURES DRAWING 19-48-4116-20PA1002.

REVISIONS				DRAFTSMAN KIC/rh	PROJ ENG AGL/William		
				CHECKER GERS	LOG ENGINEER OFFICE W. E. Smith		
				APPROVED, U. S. ARMY ARMAMENT, MUNITIONS AND CHEMICAL COMMAND			
				<i>William G. Smith</i>	<i>W. E. Smith</i>		
				APPROVED BY ORDER OF COMMANDING GENERAL U. S. ARMY MATERIEL DEVELOPMENT AND READINESS COMMAND (DARCOM)			
				<i>John L. Boyd</i> U. S. ARMY DEFENSE AMMUNITION CENTER AND SCHOOL			
				U. S. ARMY DARCOM DRAWING			
				NOVEMBER 1983			
				CLASS	DIVISION	DRAWING	FILE
				19	48	4116/ 50A	20PA 1002

DO NOT SCALE

GENERAL NOTES

- A. THIS APPENDIX CANNOT STAND ALONE BUT MUST BE USED IN CONJUNCTION WITH THE BASIC UNITIZATION PROCEDURES DRAWING 19-48-4116-20PA1002. TO PRODUCE AN APPROVED UNIT LOAD, ALL PERTINENT PROCEDURES, SPECIFICATIONS AND CRITERIA SET FORTH WITHIN THE BASIC DRAWING WILL APPLY TO THE PROCEDURES DELINEATED IN THIS APPENDIX. ANY EXCEPTIONS TO THE BASIC PROCEDURES ARE SPECIFIED IN THIS APPENDIX.
- B. DIMENSIONS, CUBE AND WEIGHT OF A PALLET UNIT WILL VARY SLIGHTLY DEPENDING UPON THE ACTUAL DIMENSIONS OF THE BOXES AND THE WEIGHT OF THE SPECIFIC ITEM BEING UNITIZED.
- C. THE LOAD STRAPS WILL BE THREADED THROUGH THE STRAP SLOTS OF A PALLET. LOAD STRAPS MUST BE TENSIONED AND SEALED PRIOR TO APPLICATION OF TIEDOWN STRAPS.
- D. INSTALL EACH TIEDOWN STRAP TO PASS UNDER THE TOP DECK BOARDS OF THE PALLET AND TO BE LOCATED AS SHOWN. TIEDOWN STRAPS WILL NOT BE APPLIED UNTIL THE LOAD STRAPS HAVE BEEN TENSIONED AND SEALED.
- E. THE FOLLOWING DARCOM DRAWINGS ARE APPLICABLE FOR OUTLOADING AND STORAGE OF THE ITEMS COVERED BY THIS APPENDIX.
 CARLOADING ----- DRAWING 19-48-4115-5PA1002
 TRUCKLOADING ----- DRAWING 19-48-4117-11PA1003
 STORAGE ----- DRAWING 19-48-4118-1-2-3-4-14-22PA1002
- F. FOR METHOD OF SECURING A STRAP CUTTER TO THE PALLET UNIT, SEE DARCOM DRAWING 19-48-4127-20P1000.
- G. IF ITEMS COVERED HEREIN ARE UNITIZED PRIOR TO ISSUANCE OF THIS APPENDIX, THE BOXES NEED NOT BE REUNITIZED SOLELY TO CONFORM TO THIS APPENDIX.
- H. THE UNITIZATION PROCEDURES DEPICTED HEREIN MAY ALSO BE USED FOR UNITIZING CANISTER, SMOKE WHEN IDENTIFIED BY DIFFERENT NATIONAL STOCK NUMBERS (NSN) THAN WHAT IS SHOWN ON THE TITLE PAGE, PROVIDED THE BOX PACK DOES NOT VARY FROM WHAT IS DELINEATED HEREIN. THE EXPLOSIVE CLASSIFICATION OF OTHER ITEMS MAY BE DIFFERENT THAN WHAT IS SHOWN.

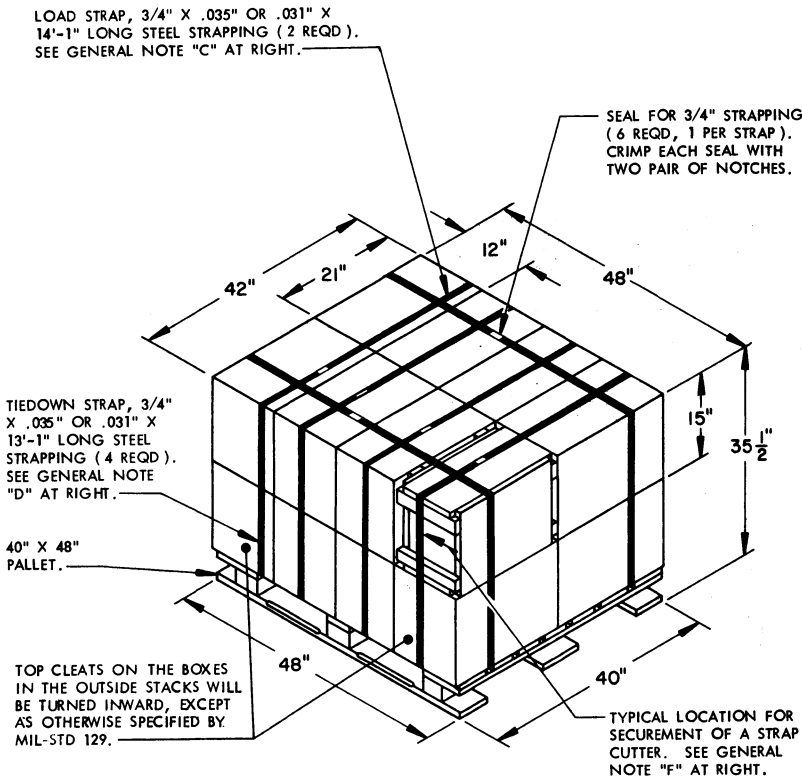

PALLET UNIT

SEE GENERAL NOTE "B" AT RIGHT.

16 BOXES OF CANISTERS (24 PER BOX) @ 192 LBS -----	3,072 LBS (APPROX)
DUNNAGE -----	6 LBS
PALLET -----	80 LBS
TOTAL WEIGHT -----	3,158 LBS (APPROX)
CUBE -----	41.1 CU FT (APPROX)

BILL OF MATERIAL

PALLET, 40" X 48" -----	1 REQD -----	80 LBS
STEEL STRAPPING, 3/4" -----	80.50' REQD -----	5.75 LBS
SEAL FOR 3/4" STEEL STRAPPING -----	6 REQD -----	NIL

TIE PIECE, 1" X 4" X BOX HEIGHT (2 REQD).
 NAIL TO LONGITUDINAL PIECES W/1-6d
 NAIL AT EACH END AND TO
 LATERAL PIECE
 W/3-6d NAILS.

VERTICAL PIECE, 2" X 4"
 X BOX WIDTH MINUS
 3/4" (4 REQD).

LATERAL PIECE, 2" X 4"
 X BOX HEIGHT (4 REQD).
 NAIL TO VERTICAL PIECES
 W/2-10d NAILS AT EACH END.

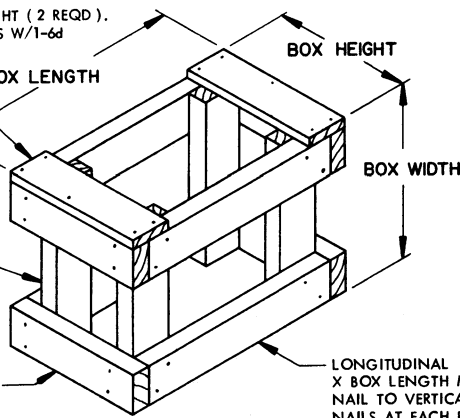

FILLER ASSEMBLY

(FOR MINUS ONE BOX)