

APPENDIX 48

UNITIZATION PROCEDURES FOR BOXED AMMUNITION AND COMPONENTS ON 4-WAY ENTRY PALLETS

REDUCER, FLASH, PROPELLING CHARGE, PACKED
40 PER WOODEN BOX, UNITIZED 30 BOXES PER
35" X 45 $\frac{1}{2}$ " PALLET; APPROX BOX SIZE 19 $\frac{1}{8}$ " L X
10 $\frac{5}{8}$ " W X 14 $\frac{3}{4}$ " H

PALLET UNIT DATA						
ITEMS INCLUDED		HAZARD CLASSIFICATION				WEIGHT (LBS)
NSN	DODIC	DOT CLASS	CG CLASS	QD CLASS	COMP GROUP	
1320-00-926-4107	D493	A	IX-A	1.1	D	2,055

NOTICE: THIS APPENDIX CANNOT STAND ALONE BUT MUST BE
USED IN CONJUNCTION WITH THE BASIC UNITIZATION
PROCEDURES DRAWING 19-48-4116-20PA1002.

REVISIONS				DRAFTSMAN 4 m H / KR	PROJ ENG B/D / [Signature]
				CHECKER RST	LOG ENGRG OFFICE [Signature]
				APPROVED, U. S. ARMY ARMAMENT MATERIEL READINESS COMMAND	
				[Signature] [Signature]	
				DRBAR-LEP	DRBAR-TMO
				APPROVED BY ORDER OF COMMANDING GENERAL, U. S. ARMY MATERIEL, DEVELOPMENT AND READINESS COMMAND (DARCOM)	
				[Signature] U. S. ARMY DEFENSE AMMUNITION CENTER AND SCHOOL	
				U. S. ARMY DARCOM DRAWING	
				MARCH 1983	
	CLASS	DIVISION	DRAWING	FILE	
	19	48	4116/48	20PA 1002	

DO NOT SCALE

GENERAL NOTES

- A. THIS APPENDIX CANNOT STAND ALONE BUT MUST BE USED IN CONJUNCTION WITH THE BASIC UNITIZATION PROCEDURES DRAWING 19-48-4116-20PA1002. TO PRODUCE AN APPROVED UNIT LOAD, ALL PERTINENT PROCEDURES, SPECIFICATIONS AND CRITERIA SET FORTH WITHIN THE BASIC DRAWING WILL APPLY TO THE PROCEDURES DELINEATED IN THIS APPENDIX. ANY EXCEPTIONS TO THE BASIC PROCEDURES ARE SPECIFIED IN THIS APPENDIX.
- B. DIMENSIONS, CUBE AND WEIGHT OF A PALLET UNIT WILL VARY SLIGHTLY DEPENDING UPON THE ACTUAL DIMENSIONS OF THE BOXES AND THE WEIGHT OF THE SPECIFIC ITEM BEING UNITIZED.
- C. THE LOAD STRAPS MAY BE THREADED THROUGH THE STRAP SLOTS OF A PALLET OR PRE-POSITIONED ON THE PALLET DECK PRIOR TO PLACING BOXES ON THE PALLET. LOAD STRAPS MUST BE TENSIONED AND SEALED PRIOR TO APPLICATION OF HORIZONTAL STRAPS.
- D. INSTALL EACH TIEDOWN STRAP TO PASS UNDER THE TOP DECK BOARDS OF THE PALLET AND TO BE LOCATED AS SHOWN. TIEDOWN STRAPS WILL BE APPLIED BUT NOT TENSIONED UNTIL THE HORIZONTAL STRAPS HAVE BEEN INSTALLED AND TENSIONED.
- E. INSTALL EACH HORIZONTAL STRAP TO ENCIRCLE A LAYER OF BOXES ON THE PALLET. HORIZONTAL STRAPS MUST BE TENSIONED AND SEALED PRIOR TO TENSIONING OF TIEDOWN STRAPS.
- F. THE FOLLOWING DARCOM DRAWINGS ARE APPLICABLE FOR OUTLOADING AND STORAGE OF THE ITEMS COVERED BY THIS APPENDIX.
 CARLOADING ----DRAWING 19-48-4115-5PA1002
 TRUCKLOADING--DRAWING 19-48-4117-11PA1003
 STORAGE-----DRAWING 19-48-4118-1-2-3-4-14-22PA1002
- G. FOR METHOD OF SECURING A STRAP CUTTER TO THE PALLET UNIT, SEE DARCOM DRAWING 19-48-4127-20P1000.
- H. IF ITEMS COVERED HEREIN ARE UNITIZED PRIOR TO ISSUANCE OF THIS APPENDIX, THE BOXES NEED NOT BE REUNITIZED SOLELY TO CONFORM TO THIS APPENDIX.
- J. THE UNITIZING PROCEDURES DEPICTED HEREIN MAY ALSO BE USED FOR UNITIZING FLASH REDUCER WHEN IDENTIFIED BY DIFFERENT NATIONAL STOCK NUMBERS (NSN) THAN WHAT IS SHOWN ON THE TITLE PAGE, PROVIDED THE BOX PACK DOES NOT VARY FROM WHAT IS DELINEATED HEREIN. THE EXPLOSIVE CLASSIFICATION OF OTHER ITEMS MAY BE DIFFERENT THAN WHAT IS SHOWN.
- K. WHEN THE UNIT LOAD DEPICTED AT LEFT IS TO BE USED FOR UNITIZING MARINE CORPS AMMUNITION, ONE LAYER OF BOXES MUST BE OMITTED, TIEDOWN STRAP LENGTHS MUST BE DECREASED TO 12'-5", AND LOAD STRAP LENGTHS MUST BE DECREASED TO 14'-11" AND ONE HORIZONTAL STRAP MUST BE OMITTED. THIS WILL RESULT IN AN OVERALL UNIT HEIGHT OF 35", A GROSS UNIT WEIGHT OF 1,392 POUNDS, AND A UNIT CUBE OF 41.2 CUBIC FEET. ADDITIONALLY, THE UNIT LOAD MAY BE MODIFIED AS DESCRIBED WHEN BEING SHIPPED BY MILVAN OR COMMERCIAL INTER-MODAL FREIGHT CONTAINER, CONVENTIONAL VAN TRAILER OR CONVENTIONAL OR HIGH-CAPACITY BOXCAR. THE DETERMINATION TO REDUCE THE LOAD BY A LAYER FOR TRANSPORTATION WILL BE MADE BY THE RESPONSIBLE COMMAND AND WILL BE BASED UPON ECONOMICS OF TRANSPORTATION AND HANDLING.
- L. THE 53-1/8" WIDTH DIMENSION OF THE UNIT LOAD DEPICTED AT LEFT IS AN EXCEPTION TO THE BASIC PROCEDURES. HOWEVER, THE EXCEPTION IS NECESSARY FOR THE AMMUNITION PACK COVERED BY THIS APPENDIX, TO MOST EFFECTIVELY GET AN ACCEPTABLE, COMPACT AND SOUND PALLET UNIT.

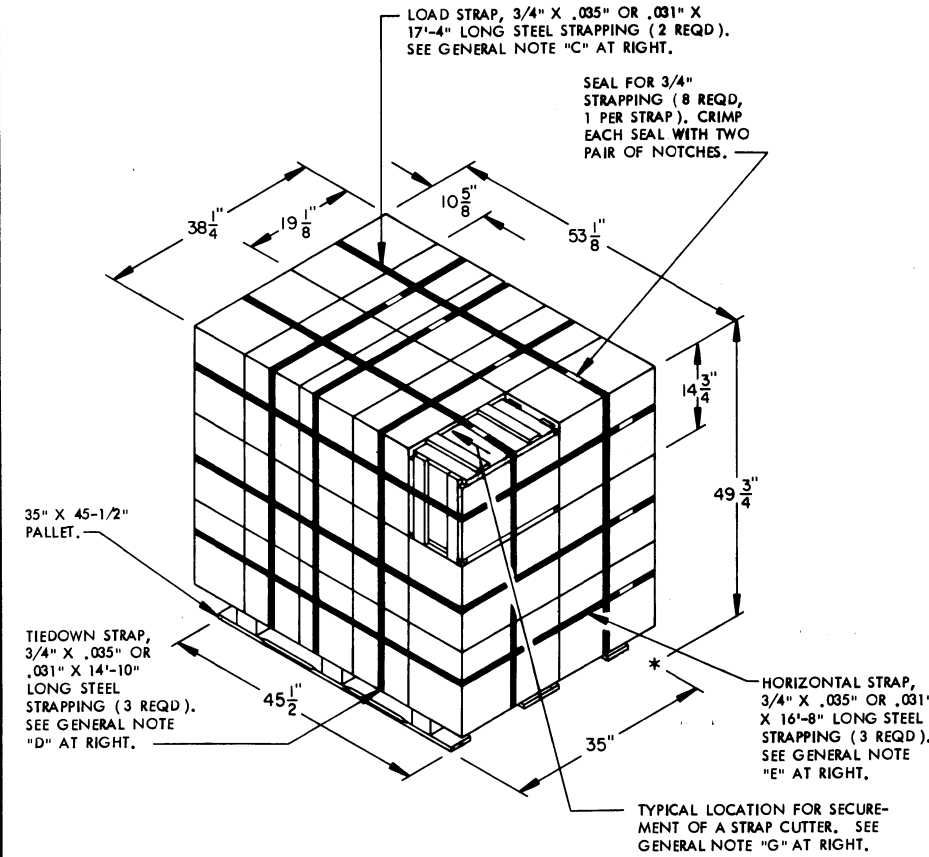

PALLET UNIT

SEE GENERAL NOTE "B" AT RIGHT.

30 BOXES OF FLASH REDUCER (40 PER BOX) @ 66 LBS -----	1,980 LBS (APPROX)
DUNNAGE -----	10 LBS
PALLET -----	65 LBS
TOTAL WEIGHT-----	2,055 LBS (APPROX)
CUBE -----	58.5 CUBIC FEET (APPROX)

BILL OF MATERIAL

PALLET, 35" X 45-1/2"-----	1 REQD-----	65 LBS
STEEL STRAPPING, 3/4"-----	129.17 REQD-----	9.23 LBS
SEAL FOR 3/4" STRAPPING-----	8 REQD-----	NIL

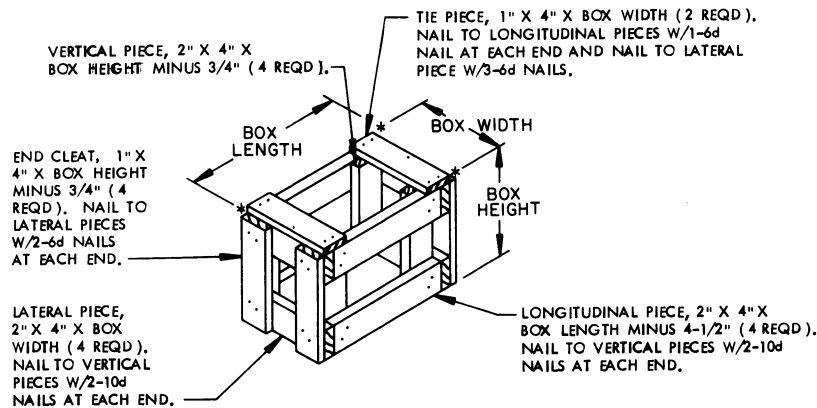

FILLER ASSEMBLY

(FOR MINUS ONE BOX)