

APPENDIX 47

UNITIZATION PROCEDURES FOR BOXED AMMUNITION AND COMPONENTS ON 4-WAY ENTRY PALLETS

CHARGE, SPOTTING, PROJECTILE, PACKED 48 PER
WIREBOUND BOX, UNITIZED 48 BOXES PER 40" X
48" PALLET; APPROX BOX SIZE 14 $\frac{5}{8}$ " L X 12 $\frac{3}{16}$ " W
X 8 $\frac{9}{16}$ " H

PALLET UNIT DATA						
ITEMS INCLUDED		HAZARD CLASSIFICATION ^①				WEIGHT (LBS)
NSN	DODIC	DOT CLASS	CG CLASS	QD CLASS	COMP GROUP	
1320- 00-171-0760	D003	A	IX-A	1.1	D	1,624

REVISIONS

REVISION NO. 1, DATED JULY 1985, CONSISTS OF:

1. CHANGING BOX DIMENSIONS.
2. UPDATING PALLET UNIT TO CONFORM WITH 1 ABOVE.

REVISION NO. 2, DATED AUGUST 1986, CONSISTS OF:

1. CHANGING QUANTITY PER BOX.
2. CHANGING BOX WEIGHT.

REVISION NO. 3, DATED OCTOBER 1988, CONSISTS OF:

1. CHANGING BOX WEIGHT.

NOTICE: THIS APPENDIX CANNOT STAND ALONE BUT MUST BE USED IN CONJUNCTION WITH THE BASIC UNITIZATION PROCEDURES DRAWING 19-48-4116-20PA1002.

^① HAZARD CLASSIFICATION DATA CONTAINED IN THE ABOVE CHART IS FOR GUIDANCE AND INFORMATIONAL PURPOSES ONLY. VERIFICATION OF THE SPECIFIED DATA SHOULD BE MADE BY CONSULTING THE MOST RECENT JOINT HAZARD CLASSIFICATION SYSTEM LISTING OR OTHER APPROVED LISTING(S).

DO NOT SCALE

REVISIONS		DESIGNER	CHKD BY	PRJ. ENG.	APP. (CRS)
1	JUL 85	<i>WRF</i>	<i>DAK</i>	<i>WRF/JES</i>	<i>WRF/JES</i>
2	AUG 86	<i>WRF</i>	<i>RSK</i>	<i>WRF/JES</i>	<i>WRF/JES</i>
3	OCT 88	<i>WRF</i>	<i>WRF</i>	<i>WRF/JES</i>	<i>WRF/JES</i>
APPROVED, U. S. ARMY ARMAMENT, MUNITIONS AND CHEMICAL COMMAND					
APPROVED BY ORDER OF COMMANDING GENERAL, U. S. ARMY MATERIEL DEVELOPMENT AND READINESS COMMAND (DARCOM)					
U. S. ARMY DEFENSE AMMUNITION CENTER AND SCHOOL					
U. S. ARMY DARCOM DRAWING					
NOVEMBER 1983					
CLASS	DIVISION	DRAWING	FILE		
19	48	4116/ 47	20PA 1002		

TIEDOWN STRAP, 3/4" X .035" OR .031" X 14'-2" LONG STEEL STRAPPING (4 REQD). SEE GENERAL NOTE "D" AT RIGHT.

LOAD STRAP, 3/4" X .035" OR .031" X 15'-4" LONG STEEL STRAPPING (3 REQD). SEE GENERAL NOTE "C" AT RIGHT.

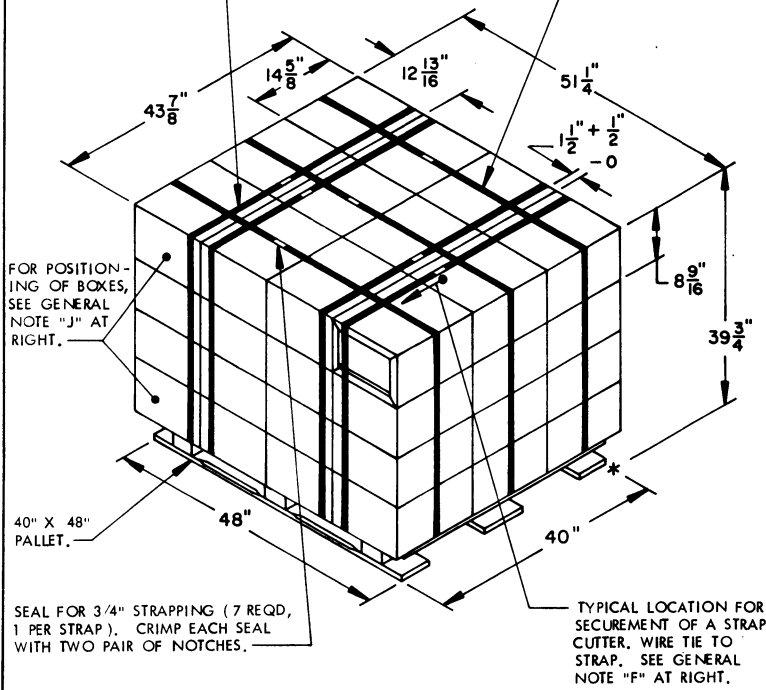

PALLET UNIT

SEE GENERAL NOTE "B" AT RIGHT.

48 BOXES OF CHARGES (48 PER BOX) @ 32 LBS	-----	1,536 LBS (APPROX)
DUNNAGE	-----	8 LBS
PALLET	-----	80 LBS
TOTAL WEIGHT	-----	1,624 LBS (APPROX)
CUBE	-----	51.75 CU FT (APPROX)

BILL OF MATERIAL

PALLET 40" X 48"	-----	1 REQD	-----	80 LBS
STEEL STRAPPING, 3/4"	-----	102.42' REQD	-----	7,32 LBS
SEAL FOR 3/4" STRAPPING	-----	7 REQD	-----	NIL

GENERAL NOTES

- A. THIS APPENDIX CANNOT STAND ALONE BUT MUST BE USED IN CONJUNCTION WITH THE UNITIZATION PROCEDURES DRAWING 19-48-4116-20PA1002. TO PRODUCE AN APPROVED UNIT LOAD, ALL PERTINENT PROCEDURES, SPECIFICATIONS AND CRITERIA SET FORTH WITHIN THE BASIC DRAWING WILL APPLY TO THE PROCEDURES DELINEATED IN THIS APPENDIX. ANY EXCEPTIONS TO THE BASIC PROCEDURES ARE SPECIFIED IN THIS APPENDIX.
- B. DIMENSIONS, CUBE AND WEIGHT OF A PALLET UNIT WILL VARY SLIGHTLY DEPENDING UPON THE ACTUAL DIMENSIONS OF THE BOXES AND THE WEIGHT OF THE SPECIFIC ITEM BEING UNITIZED.
- C. THE LOAD STRAPS MAY BE THREADED THROUGH THE STRAP SLOTS OF A PALLET OR PRE-POSITIONED ON THE PALLET DECK PRIOR TO PLACING BOXES ON THE PALLET. LOAD STRAPS MUST BE TENSIONED AND SEALED PRIOR TO APPLICATION OF TIEDOWN STRAPS.
- D. INSTALL EACH TIEDOWN STRAP TO PASS UNDER THE TOP DECK BOARDS OF THE PALLET AND TO BE LOCATED AS SHOWN. NOTE THAT THE STRAPS WILL BE LOCATED AS DIMENSIONED, NEAR THE SIDE CLEATS OF THE END PANELS OF THE BOX. TIEDOWN STRAPS WILL NOT BE APPLIED UNTIL THE LOAD STRAPS HAVE BEEN TENSIONED AND SEALED.
- E. THE FOLLOWING AMC (DARCOM) DRAWINGS ARE APPLICABLE FOR OUTLOADING AND STORAGE OF THE ITEMS COVERED BY THIS APPENDIX.

CARLOADING	-----	DRAWING 19-48-4115-5PA1002
TRUCKLOADING	-----	DRAWING 19-48-4117-11PA1003
STORAGE	-----	DRAWING 19-48-4118-1-2-3-4-14-22PA1002
- F. FOR METHOD OF SECURING A STRAP CUTTER TO THE PALLET UNIT, SEE DARCOM DRAWING 19-48-4127-20P1000.
- G. IF ITEMS COVERED HEREIN ARE UNITIZED PRIOR TO ISSUANCE OF THIS APPENDIX, THE BOXES NEED NOT BE REUNITIZED SOLELY TO CONFORM TO THIS APPENDIX.
- H. THE UNITIZATION PROCEDURES DEPICTED HEREIN MAY ALSO BE USED FOR UNITIZING SPOTTING CHARGES WHEN IDENTIFIED BY DIFFERENT NATIONAL STOCK NUMBERS (NSN) THAN WHAT IS SHOWN ON THE TITLE PAGE, PROVIDED THE BOX PACK DOES NOT VARY FROM WHAT IS DELINEATED HEREIN. THE EXPLOSIVE CLASSIFICATION OF OTHER ITEMS MAY BE DIFFERENT THAN WHAT IS SHOWN.
- J. POSITION THE THREE OUTBOARD BOXES ON THE 40" SIDES OF THE BOTTOM LAYER OF THE UNIT WITH THE TOPS DOWNWARD AND THE THREE OUTBOARD BOXES ON THE 40" SIDES OF THE TOP LAYER OF THE UNIT WITH THE TOPS UPWARD.
- K. THE STYLE I PALLET DELINEATED IN THE DETAIL AT LEFT NEED NOT HAVE CHAMFERS OR STRAP SLOTS AS SPECIFIED WITHIN MILITARY SPECIFICATION MIL-P-15011 WHEN USED FOR THE UNITIZATION OF THE ITEMS COVERED BY THIS APPENDIX. IF THE PALLET TO BE USED DOES NOT HAVE STRAP SLOTS, HOWEVER, THE LOAD STRAPS MUST BE PREPOSITIONED ON THE PALLET DECK PRIOR TO PLACING THE BOXES ON THE PALLET.

