

# APPENDIX 45R

## UNITIZATION PROCEDURES FOR BOXED AMMUNITION AND COMPONENTS ON 4-WAY ENTRY PALLETS

PROJECTILE, TRACER, PACKED 1,600 PER WOODEN  
BOX, UNITIZED 18 BOXES PER 35" X 45 $\frac{1}{2}$ " PALLET;  
APPROX BOX SIZE 24 $\frac{7}{8}$ " L X 13 $\frac{3}{32}$ " W X 11 $\frac{17}{32}$ " H

| PALLET UNIT DATA |       |                                    |          |          |            |        |
|------------------|-------|------------------------------------|----------|----------|------------|--------|
| ITEMS INCLUDED   |       | HAZARD CLASSIFICATION <sup>①</sup> |          |          |            | WEIGHT |
| NSN              | DODIC | DOT CLASS                          | CG CLASS | QD CLASS | COMP GROUP | (LBS)  |
| 1315-00-229-6535 | C422  | C                                  | II-C     | 1.3      | G          | 1,493  |

### REVISIONS

REVISION NO. 1, DATED JUNE 1986, CONSISTS OF:

1. CHANGING BOX DIMENSIONS.
2. UPDATING "PALLET UNIT DATA" CHART.

REVISION NO. 2, DATED DECEMBER 1986, CONSISTS OF:

CHANGING QUANTITY PER UNIT PACK.

NOTICE: THIS APPENDIX CANNOT STAND ALONE BUT MUST BE USED IN CONJUNCTION WITH THE BASIC UNITIZATION PROCEDURES DRAWING 19-48-4116-20PA1002.

<sup>①</sup> HAZARD CLASSIFICATION DATA CONTAINED IN THE ABOVE CHART IS FOR GUIDANCE AND INFORMATION PURPOSES ONLY. VERIFICATION OF THE SPECIFIED DATA SHOULD BE MADE BY CONSULTING THE MOST RECENT JOINT HAZARD CLASSIFICATION SYSTEM LISTING OR OTHER APPROVED LISTING(S).

| REVISIONS |          | DRAFTSMAN   | PROJ ENG     | CHKD BY          |
|-----------|----------|---|--------------|------------------|
| 1         | JUN 86   | <i>WIRE</i>   | <i>WIRE</i>  | <i>WIRE</i>      |
| 2         | DEC 86   | <i>MWD</i>  | <i>MWD</i>   | <i>MWD</i>       |
|           |          | SMCAR - ESX   | AMSC - TMO   | LOG ENGRG OFFICE |
|           |          | APPROVED BY ORDER OF COMMANDING GENERAL, U. S. ARMY MATERIEL DEVELOPMENT AND READINESS COMMAND (DARCOM) |              |                  |
|           |          | U. S. ARMY DEFENSE AMMUNITION CENTER AND SCHOOL   |              |                  |
|           |          | U. S. ARMY DARCOM DRAWING   |              |                  |
|           |          | NOVEMBER 1983   |              |                  |
| CLASS     | DIVISION | DRAWING   | FILE         |                  |
| 19        | 48       | 4116/<br>45R  | 20PA<br>1002 |                  |

DO NOT SCALE

**GENERAL NOTES**

- A. THIS APPENDIX CANNOT STAND ALONE BUT MUST BE USED IN CONJUNCTION WITH THE BASIC UNITIZATION PROCEDURES DRAWING 19-48-4116-20PA1002. TO PRODUCE AN APPROVED UNIT LOAD, ALL PERTINENT PROCEDURES, SPECIFICATIONS AND CRITERIA SET FORTH WITHIN THE BASIC DRAWING WILL APPLY TO THE PROCEDURES DELINEATED IN THIS APPENDIX. ANY EXCEPTIONS TO THE BASIC PROCEDURES ARE SPECIFIED IN THIS APPENDIX.
- B. DIMENSIONS, CUBE AND WEIGHT OF A PALLET UNIT WILL VARY SLIGHTLY DEPENDING UPON THE ACTUAL DIMENSIONS OF THE BOXES AND THE WEIGHT OF THE SPECIFIC ITEM BEING UNITIZED.
- C. THE LOAD STRAPS MAY BE THREADED THROUGH THE STRAP SLOTS OF THE PALLET OR PRE-POSITIONED ON THE PALLET DECK PRIOR TO PLACING BOXES ON THE PALLET.
- D. INSTALL EACH TIEDOWN STRAP TO PASS UNDER THE TOP DECK BOARDS OF THE PALLET AND TO BE LOCATED AS SHOWN. TIEDOWN STRAPS WILL BE TENSIONED AND SEALED PRIOR TO LOAD STRAPS.
- E. THE FOLLOWING AMC (DARCOM) DRAWINGS ARE APPLICABLE FOR OUTLOADING AND STORAGE OF THE ITEMS COVERED BY THIS APPENDIX.
  - CARLOADING --- DRAWING 19-48-4115-5PA1002
  - TRUCKLOADING -- DRAWING 19-48-4117-11PA1003
  - STORAGE ----- DRAWING 19-48-4118-1-2-3-4-14-22PA1002
- F. FOR METHOD OF SECURING A STRAP CUTTER TO THE PALLET UNIT, SEE DARCOM DRAWING 19-48-4127-20P1000.
- G. IF ITEMS COVERED HEREIN ARE UNITIZED PRIOR TO ISSUANCE OF THIS APPENDIX, THE BOXES NEED NOT BE REUNITIZED SOLELY TO CONFORM TO THIS APPENDIX.
- H. THE UNITIZATION PROCEDURES DEPICTED HEREIN MAY ALSO BE USED FOR UNITIZING PROJECTILES, TRACER WHEN IDENTIFIED BY DIFFERENT NATIONAL STOCKS NUMBERS (NSN) THAN WHAT IS SHOWN ON THE TITLE PAGE, PROVIDED THE BOX PACK DOES NOT VARY FROM WHAT IS DELINEATED HEREIN. THE EXPLOSIVE CLASSIFICATION OF OTHER ITEMS MAY BE DIFFERENT THAN WHAT IS SHOWN.
- J. THE 39-1/4" LENGTH DIMENSION OF THE UNIT LOAD DEPICTED AT LEFT IS AN EXCEPTION TO THE BASIC PROCEDURES. HOWEVER, THE EXCEPTION IS NECESSARY FOR THE AMMUNITION PACK COVERED BY THIS APPENDIX, TO MOST EFFECTIVELY GET AN ACCEPTABLE, COMPACT AND SOUND PALLET UNIT.

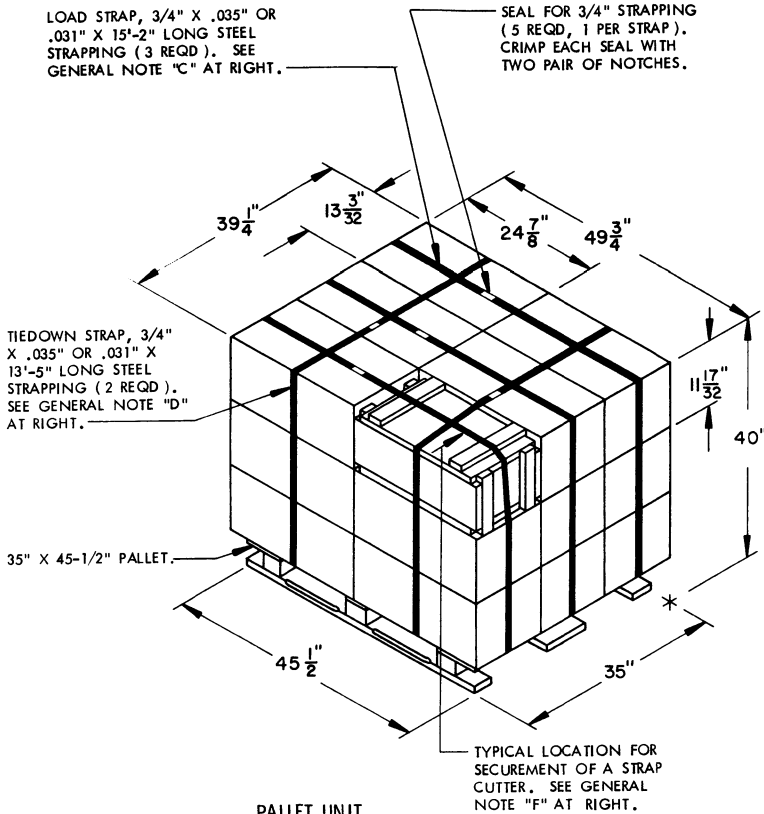

**PALLET UNIT**

SEE GENERAL NOTE "B" AT RIGHT.

|  |                            |
|--|----------------------------|
| 18 BOXES OF PROJECTILES (1,600 PER BOX) @ 79 LBS ----- | 1,422 LBS (APPROX)         |
| DUNNAGE -----  | 6 LBS                      |
| PALLET -----   | 65 LBS                     |
| <b>TOTAL WEIGHT -----</b>                              | <b>1,493 LBS (APPROX)</b>  |
| <b>CUBE -----</b>                                      | <b>45.2 CU FT (APPROX)</b> |

**BILL OF MATERIAL**

|                               |                   |          |
|-------------------------------|-------------------|----------|
| PALLET, 35" X 45-1/2" -----   | 1 REQD -----      | 65 LBS   |
| STEEL STRAPPING, 3/4" -----   | 72.33' REQD ----- | 5.17 LBS |
| SEAL FOR 3/4" STRAPPING ----- | 5 REQD -----      | NIL      |

