

# APPENDIX 45C

## UNITIZATION PROCEDURES FOR BOXED AMMUNITION AND COMPONENTS ON 4-WAY ENTRY PALLETS

**CARTRIDGE, 105 MM, PACKED 2 PER WOODEN BOX,  
UNITIZED 16 BOXES PER 35" X 45½" PALLET;  
APPROX BOX SIZE 38⅛" L X 12" W X 8⅛" H**

PALLET UNIT DATA						
ITEMS INCLUDED		HAZARD CLASSIFICATION <sup>①</sup>				WEIGHT
NSN	DODIC	DOT CLASS	CG CLASS	QD CLASS	COMP GROUP	( LBS )
1315-01-080-9415	C522					1,719

**NOTICE:** THIS APPENDIX CANNOT STAND ALONE BUT MUST BE USED IN CONJUNCTION WITH THE BASIC UNITIZATION PROCEDURES DRAWING 19-48-4116-20PA1002.

① HAZARD CLASSIFICATION DATA CONTAINED IN THE ABOVE CHART IS FOR GUIDANCE AND INFORMATIONAL PURPOSES ONLY. VERIFICATION OF THE SPECIFIED DATA SHOULD BE MADE BY CONSULTING THE MOST RECENT JOINT HAZARD CLASSIFICATION SYSTEM LISTING OR OTHER APPROVED LISTING(S).

REVISIONS				DRAFTSMAN rh	PROJ ENG rh
				CHECKER rh	LOG ENGRG OFFICE W.F. Ernst
				APPROVED U.S. ARMY ARMAMENT, MUNITIONS AND CHEMICAL COMMAND	
				<i>Math Henton</i> DRMCM - LEP	<i>John L. Bynum</i> DRMCM - TMD
				APPROVED BY ORDER OF COMMANDING GENERAL U.S. ARMY MATERIAL DEVELOPMENT AND READINESS COMMAND (DARCOM)	
				<i>John L. Bynum</i> U.S. ARMY DEFENSE AMMUNITION CENTER AND SCHOOL	
				<b>U. S. ARMY DARCOM DRAWING</b>	
				<b>FEBRUARY 1984</b>	
				CLASS	DIVISION
				DRAWING	FILE
				19	48
				4116/ 45C	20PA 1002

**DO NOT SCALE**

**GENERAL NOTES**

LOAD STRAP, 3/4" X .035" OR .031" X 14'-6" LONG STEEL STRAPPING (2 REQD). SEE GENERAL NOTE "C" AT RIGHT.

SEAL FOR 3/4" STRAPPING (6 REQD, 1 PER STRAP). CRIMP EACH SEAL WITH TWO PAIR OF NOTCHES.

TIEDOWN STRAP, 3/4" X .035" OR .031" X 12'-11" LONG STEEL STRAPPING (4 REQD). SEE GENERAL NOTE "D" AT RIGHT.

35" X 45-1/2" PALLET.

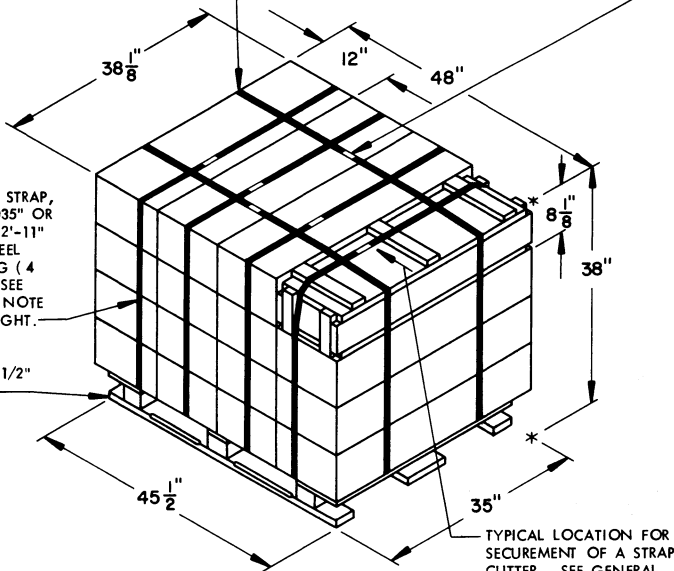

**PALLET UNIT**

SEE GENERAL NOTE "B" AT RIGHT.

- A. THIS APPENDIX CANNOT STAND ALONE BUT MUST BE USED IN CONJUNCTION WITH THE BASIC UNITIZATION PROCEDURES DRAWING 19-48-4116-20PA1002. TO PRODUCE AN APPROVED UNIT LOAD, ALL PERTINENT PROCEDURES, SPECIFICATIONS AND CRITERIA SET FORTH WITHIN THE BASIC DRAWING WILL APPLY TO THE PROCEDURES DELINEATED IN THIS APPENDIX. ANY EXCEPTIONS TO THE BASIC PROCEDURES ARE SPECIFIED IN THIS APPENDIX.
- B. DIMENSIONS, CUBE AND WEIGHT OF A PALLET UNIT WILL VARY SLIGHTLY DEPENDING UPON THE ACTUAL DIMENSIONS OF THE BOXES AND THE WEIGHT OF THE SPECIFIC ITEM BEING UNITIZED.
- C. THE LOAD STRAPS WILL BE THREADED THROUGH THE STRAP SLOTS OF THE PALLET. LOAD STRAPS MUST BE TENSIONED AND SEALED PRIOR TO APPLICATION OF TIEDOWN STRAPS.
- D. INSTALL EACH TIEDOWN STRAP TO PASS UNDER THE TOP DECK BOARDS OF THE PALLET AND TO BE LOCATED AS SHOWN. TIEDOWN STRAPS WILL NOT BE APPLIED UNTIL THE LOAD STRAPS HAVE BEEN TENSIONED AND SEALED.
- E. THE FOLLOWING DARCOM DRAWINGS ARE APPLICABLE FOR OUTLOADING AND STORAGE OF THE ITEMS COVERED BY THIS APPENDIX.  
 CARLOADING-----DRAWING 19-48-4115-5PA1002  
 TRUCKLOADING ----DRAWING 19-48-4117-11PA1003  
 STORAGE-----DRAWING 19-48-4118-1-2-3-4-14-22PA1002
- F. FOR METHOD OF SECURING A STRAP CUTTER TO THE PALLET UNIT, SEE DARCOM DRAWING 19-48-4127-20P1000.
- G. IF ITEMS COVERED HEREIN ARE UNITIZED PRIOR TO ISSUANCE OF THIS APPENDIX, THE BOXES NEED NOT BE REUNITIZED SOLELY TO CONFORM TO THIS APPENDIX.
- H. THE UNITIZATION PROCEDURES DEPICTED HEREIN MAY ALSO BE USED FOR UNITIZING 105MM CARTRIDGES WHEN IDENTIFIED BY DIFFERENT NATIONAL STOCK NUMBERS (NSN) THAN WHAT IS SHOWN ON THE TITLE PAGE, PROVIDED THE BOX PACK DOES NOT VARY FROM WHAT IS DELINEATED HEREIN. THE EXPLOSIVE CLASSIFICATION OF OTHER ITEMS MAY BE DIFFERENT THAN WHAT IS SHOWN.

16 BOXES OF 105MM CARTRIDGES (2 PER BOX) @ 103 LBS	-----	1,648 LBS (APPROX)
DUNNAGE	-----	6 LBS
PALLET	-----	65 LBS
<b>TOTAL WEIGHT</b>	-----	<b>1,719 LBS (APPROX)</b>
<b>CUBE</b>	-----	<b>40.2 CU FT (APPROX)</b>

**BILL OF MATERIAL**

PALLET, 35" X 45-1/2"	-----	1 REQD	-----	65 LBS
STEEL STRAPPING, 3/4"	-----	80.67' REQD	-----	5.76 LBS
SEAL FOR 3/4" STRAPPING	-----	6 REQD	-----	NIL

TIE PIECE, 1" X 4" X BOX WIDTH (3 REQD). NAIL TO LONGITUDINAL PIECES W/2-6d NAILS AT EACH END AND TO LATERAL PIECE W/1-6d NAIL.

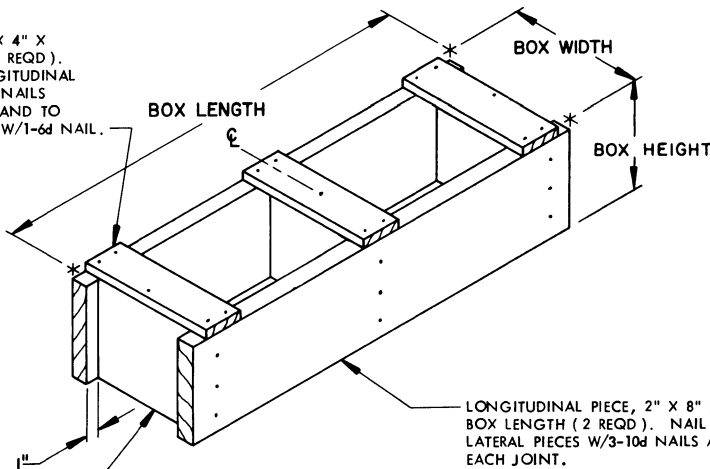

LONGITUDINAL PIECE, 2" X 8" X BOX LENGTH (2 REQD). NAIL TO LATERAL PIECES W/3-10d NAILS AT EACH JOINT.

LATERAL PIECE, 2" X 8" X BOX WIDTH MINUS 3" (3 REQD).

**FILLER ASSEMBLY**  
(FOR MINUS ONE BOX)