

APPENDIX 44D

UNITIZATION PROCEDURES FOR BOXED AMMUNITION AND COMPONENTS ON 4-WAY ENTRY PALLETS

CARTRIDGE, 90MM, PACKED 2 PER WOODEN BOX,
UNITIZED 20 BOXES PER 35" X 45½" PALLET;
APPROX BOX SIZE 40½" L X 12¾" W X 6⅝" H

PALLET UNIT DATA						
ITEMS INCLUDED		HAZARD CLASSIFICATION ^①				WEIGHT
NSN	DODIC	DOT CLASS	CG CLASS	QD CLASS	COMP GROUP	(LBS)
1315-						
00-143-8472	C294	A	IV	(12)1.2	E	2,191
00-890-2087	C294	A	IV	(12)1.2	E	2,191
00-889-2087	C294	A	IV	(12)1.2	E	2,251
00-892-4113	C294	A	IV	(12)1.2	E	2,251

① HAZARD CLASSIFICATION DATA CONTAINED IN THE ABOVE CHART IS FOR GUIDANCE AND INFORMATIONAL PURPOSES ONLY. VERIFICATION OF THE SPECIFIED DATA SHOULD BE MADE BY CONSULTING THE MOST RECENT JOINT HAZARD CLASSIFICATION SYSTEM LISTING OR OTHER APPROVED LISTING(S).

NOTICE: THIS APPENDIX CANNOT STAND ALONE BUT MUST BE USED IN CONJUNCTION WITH THE BASIC UNITIZATION PROCEDURES DRAWING 19-48-4116-20PA1002.

REVISIONS

REVISION NO. 1, DATED NOVEMBER 1983, CONSISTS OF:

1. ADDING ITEMS BY NATIONAL STOCK NUMBER TO "PALLET UNIT DATA" CHART.
2. UPDATE STORAGE DRAWING NUMBER.

DO NOT SCALE

REVISIONS				DRAFTSMAN	PROJ. ENG.
1	NOV 83	ADD NOTE	DRMHC-LEP	P.B. [Signature]	[Signature]
			DRMHC-TMD	RSH	[Signature]
				APPROVED, U. S. ARMY ARMAMENT MATERIEL READINESS COMMAND	
				DRBAR-MAD	DRBAR-TMD
				APPROVED BY ORDER OF COMMANDING GENERAL, U. S. ARMY MATERIEL DEVELOPMENT AND READINESS COMMAND (DARCOM)	
				[Signature]	
				U. S. ARMY DEFENSE AMMUNITION CENTER AND SCHOOL	
				JULY 1979	
			CLASS	DIVISION	DRAWING
			19	48	4116/ 44D
					FILE
					20PA 1002

GENERAL NOTES

- A. THIS APPENDIX CANNOT STAND ALONE BUT MUST BE USED IN CONJUNCTION WITH THE BASIC UNITIZATION PROCEDURES DRAWING 19-48-4116-20PA1002. TO PRODUCE AN APPROVED UNIT LOAD, ALL PERTINENT PROCEDURES, SPECIFICATIONS AND CRITERIA SET FORTH WITHIN THE BASIC DRAWING WILL APPLY TO THE PROCEDURES DELINEATED IN THIS APPENDIX. ANY EXCEPTIONS TO THE BASIC PROCEDURES ARE SPECIFIED IN THIS APPENDIX.
- B. DIMENSIONS, CUBE AND WEIGHT OF A PALLET UNIT WILL VARY SLIGHTLY DEPENDING UPON THE ACTUAL DIMENSIONS OF THE BOXES AND THE WEIGHT OF THE SPECIFIC ITEM BEING UNITIZED.
- C. THE LOAD STRAPS MAY BE THREADED THROUGH THE STRAP SLOTS OF A PALLET OR PRE-POSITIONED ON THE PALLET DECK PRIOR TO PLACING BOXES ON THE PALLET. LOAD STRAPS MUST BE TENSIONED AND SEALED PRIOR TO APPLICATION OF TIEDOWN STRAPS.
- D. INSTALL EACH TIEDOWN STRAP TO PASS UNDER THE TOP DECK BOARDS OF THE PALLET AND TO BE LOCATED AS SHOWN. TIEDOWN STRAPS WILL NOT BE APPLIED UNTIL THE LOAD STRAPS HAVE BEEN TENSIONED AND SEALED.
- E. THE FOLLOWING DARCOM DRAWINGS ARE APPLICABLE FOR OUTLOADING AND STORAGE OF THE ITEMS COVERED BY THIS APPENDIX.

CARLOADING -----	DRAWING 19-48-4115-5PA1002
TRUCKLOADING -----	DRAWING 19-48-4117-11PA1003
STORAGE -----	DRAWING 19-48-4118-1-2-3-4-14-22PA1002
- F. FOR METHOD OF SECURING A STRAP CUTTER TO THE PALLET UNIT, SEE DARCOM DRAWING 19-48-4127-20P1000.
- G. IF ITEMS COVERED HEREIN ARE UNITIZED PRIOR TO ISSUANCE OF THIS APPENDIX, THE BOXES NEED NOT BE REUNITIZED SOLELY TO CONFORM TO THIS APPENDIX.
- H. THE UNITIZATION PROCEDURES DEPICTED HEREIN MAY ALSO BE USED FOR UNITIZING 90MM CARTRIDGES WHEN IDENTIFIED BY DIFFERENT NATIONAL STOCK NUMBERS (NSN) THAN WHAT IS SHOWN ON THE TITLE PAGE, PROVIDED THE BOX PACK DOES NOT VARY FROM WHAT IS DELINEATED HEREIN. THE EXPLOSIVE CLASSIFICATION OF OTHER ITEMS MAY BE DIFFERENT THAN WHAT IS SHOWN.
- J. THE 40-1/2" LENGTH DIMENSION OF THE UNIT LOAD DEPICTED AT THE LEFT IS AN EXCEPTION TO THE BASIC PROCEDURES. HOWEVER, THE EXCEPTION IS NECESSARY FOR THE AMMUNITION PACK COVERED BY THIS APPENDIX, TO MOST EFFECTIVELY GET AN ACCEPTABLE, COMPACT AND SOUND PALLET UNIT.

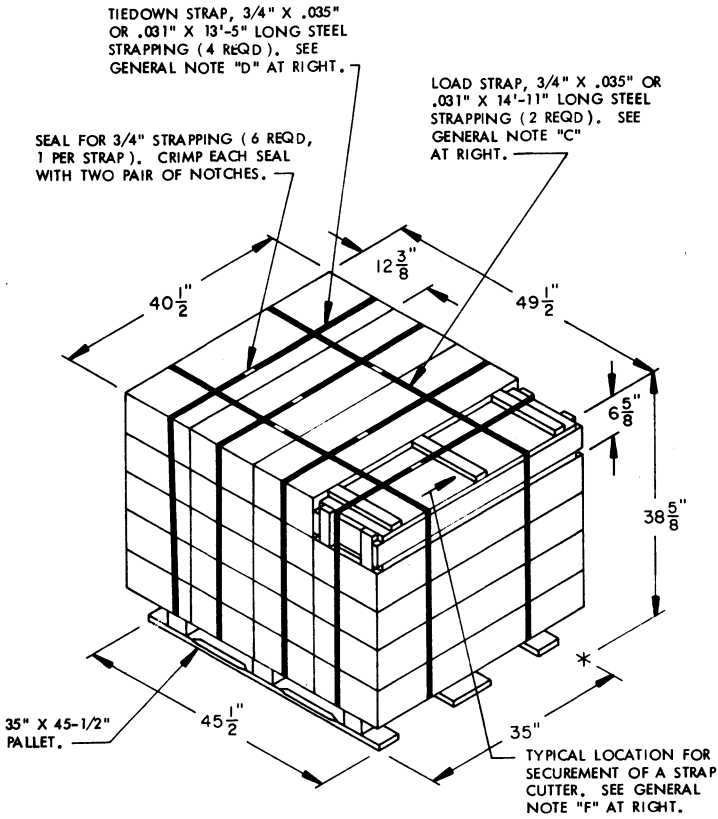

PALLET UNIT

SEE GENERAL NOTE "B" AT RIGHT.

20 BOXES OF 90MM CARTRIDGES (2 PER BOX) @ 106 LBS -----	2,120 LBS (APPROX)
DUNNAGE -----	6 LBS
PALLET -----	65 LBS
TOTAL WEIGHT -----	2,191 LBS (APPROX)
CUBE -----	44.8 CU FT (APPROX)

BILL OF MATERIAL

PALLET, 35" X 45-1/2" -----	1 REQD -----	65 LBS
STEEL STRAPPING, 3/4" -----	83.50' REQD -----	5.96 LBS
SEAL FOR 3/4" STRAPPING -----	6 REQD -----	NIL

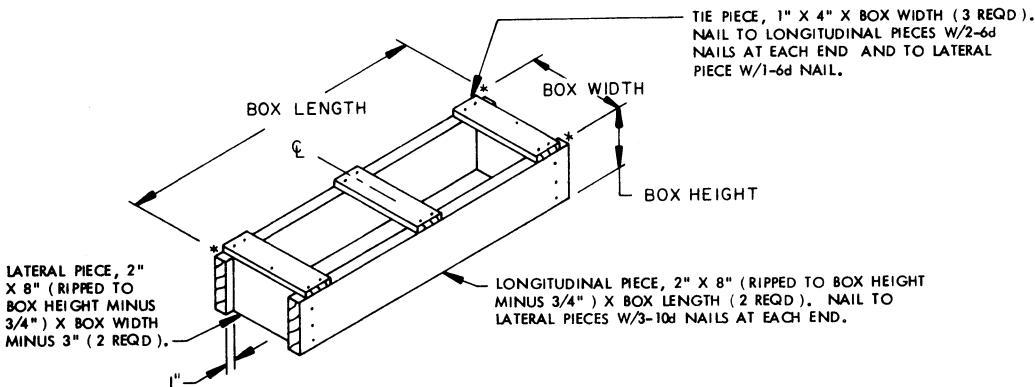

FILLER ASSEMBLY

(FOR MINUS ONE BOX)