

APPENDIX 44C

UNITIZATION PROCEDURES FOR BOXED AMMUNITION AND COMPONENTS ON 4-WAY ENTRY PALLETS

CARTRIDGE, 90 MM CANISTER, PACKED 6 PER
WOODEN BOX, UNITIZED 18 BOXES PER 35" X 45 $\frac{1}{2}$ "
PALLET; APPROX BOX SIZE 22 $\frac{3}{4}$ " L X 13 $\frac{1}{2}$ " W X 10 $\frac{1}{16}$ " H

PALLET UNIT DATA						
ITEMS INCLUDED		HAZARD CLASSIFICATION				WEIGHT (LBS)
NSN	DODIC	DOT CLASS	CG CLASS	QD CLASS	COMP GROUP	
1315- 00-926-9243	C410	B	II-B	(08) 1.2	C	1,116

NOTICE: THIS APPENDIX CANNOT STAND ALONE BUT MUST
BE USED IN CONJUNCTION WITH THE BASIC UNITIZATION
PROCEDURES DRAWING 19-48-4116-20PA1002.

REVISIONS				DRAFTSMAN <i>RSE/mak</i>	PROJ ENG <i>WJH/nllus</i>
				CHECKER <i>RSH</i>	LOG ENGRG OFFICER <i>John G. ...</i>
APPROVED, U. S. ARMY ARMAMENT MATERIEL READINESS COMMAND					
			<i>Samuel K. ...</i> <i>C. Feltner</i> <small>DRSAR - MAD</small> <small>DRSAR - TMO</small>		
APPROVED BY ORDER OF COMMANDING GENERAL, U. S. ARMY MATERIEL DEVELOPMENT AND READINESS COMMAND (DARCOM)					
<i>John L. ...</i> <small>U. S. ARMY DEFENSE AMMUNITION CENTER AND SCHOOL</small>					
U. S. ARMY DARCOM DRAWING					
JUNE 1980					
CLASS	DIVISION	DRAWING	FILE		
19	48	4116/ 44C	20PA 1002		

DO NOT SCALE

TIEDOWN STRAP, 3/4" X .035" OR .031" X 12'-11" LONG STEEL STRAPPING (4 REQD). SEE GENERAL NOTE "D" AT RIGHT.

SEAL FOR 3/4" STRAPPING (7 REQD, 1 PER STRAP). CRIMP EACH SEAL WITH TWO PAIR OF NOTCHES.

LOAD STRAP, 3/4" X .035" OR .031" X 13'-9" LONG STEEL STRAPPING (3 REQD). SEE GENERAL NOTE "C" AT RIGHT.

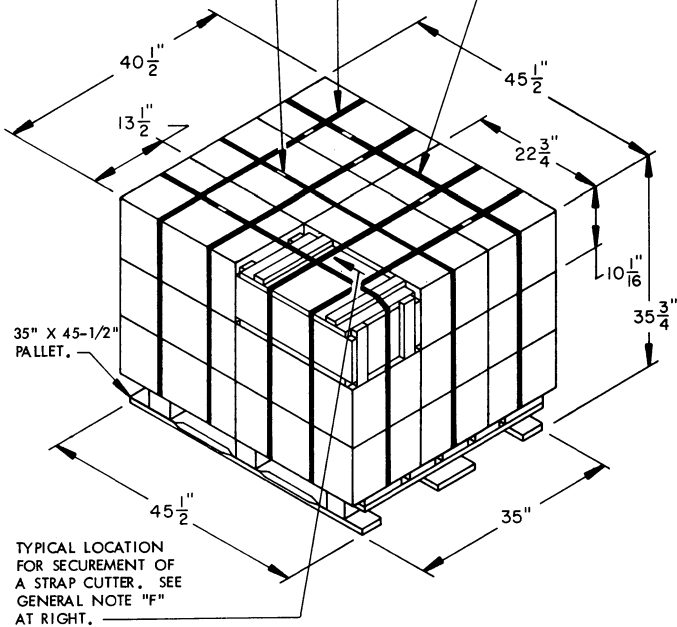

PALLET UNIT

SEE GENERAL NOTE "B" AT RIGHT.

18 BOXES OF 90MM CARTRIDGE (6 PER BOX) @ 58 LBS-----	1,044 LBS (APPROX)
DUNNAGE -----	7 LBS
PALLET -----	65 LBS
TOTAL WEIGHT -----	1,116 LBS (APPROX)
CUBE -----	38.1 CU FT (APPROX)

BILL OF MATERIAL

PALLET, 35" X 45-1/2" -----	1 REQD -----	65 LBS
STEEL STRAPPING, 3/4" -----	92.92' REQD -----	6.64 LBS
SEAL FOR 3/4" STRAPPING -----	7 REQD -----	NIL

GENERAL NOTES

- A. THIS APPENDIX CANNOT STAND ALONE BUT MUST BE USED IN CONJUNCTION WITH THE BASIC UNITIZATION PROCEDURES DRAWING 19-48-4116-20PA1002. TO PRODUCE AN APPROVED UNIT LOAD, ALL PERTINENT PROCEDURES, SPECIFICATIONS AND CRITERIA SET FORTH WITHIN THE BASIC DRAWING WILL APPLY TO THE PROCEDURES DELINEATED IN THIS APPENDIX. ANY EXCEPTIONS TO THE BASIC PROCEDURES ARE SPECIFIED IN THIS APPENDIX.
- B. DIMENSIONS, CUBE AND WEIGHT OF A PALLET UNIT WILL VARY SLIGHTLY DEPENDING UPON THE ACTUAL DIMENSIONS OF THE BOXES AND THE WEIGHT OF THE SPECIFIC ITEM BEING UNITIZED.
- C. THE LOAD STRAPS WILL BE PRE-POSITIONED ON THE PALLET DECK PRIOR TO PLACING BOXES ON THE PALLET.
- D. INSTALL EACH TIEDOWN STRAP TO PASS UNDER THE TOP DECK BOARDS OF THE PALLET AND TO BE LOCATED AS SHOWN. TIEDOWN STRAPS WILL BE TENSIONED AND SEALED PRIOR TO LOAD STRAPS.
- E. THE FOLLOWING DARCOM DRAWINGS ARE APPLICABLE FOR OUTLOADING AND STORAGE OF THE ITEMS COVERED BY THIS APPENDIX.

CARLOADING -----	DRAWING 19-48-4115-5PA1002
TRUCKLOADING -----	DRAWING 19-48-4117-11PA1003
STORAGE -----	DRAWING 19-48-4118-1-2-14-22PA1002
- F. FOR METHOD OF SECURING A STRAP CUTTER TO THE PALLET UNIT, SEE DARCOM DRAWING 19-48-4127-20P1000.
- G. IF ITEMS COVERED HEREIN ARE UNITIZED PRIOR TO ISSUANCE OF THIS APPENDIX, THE BOXES NEED NOT BE REUNITIZED SOLELY TO CONFORM TO THIS APPENDIX.
- H. THE UNITIZATION PROCEDURES DEPICTED HEREIN MAY ALSO BE USED FOR UNITIZING 90MM CARTRIDGES WHEN IDENTIFIED BY DIFFERENT NATIONAL STOCK NUMBERS (NSN) THAN WHAT IS SHOWN ON THE TITLE PAGE, PROVIDED THE BOX PACK DOES NOT VARY FROM WHAT IS DELINEATED HEREIN. THE EXPLOSIVE CLASSIFICATION OF OTHER ITEMS MAY BE DIFFERENT THAN WHAT IS SHOWN.

TIE PIECE, 1" X 4" X BOX WIDTH (2 REQD). NAIL TO LONGITUDINAL PIECES W/2-6d NAILS AT EACH END AND TO LATERAL PIECE W/1-6d NAILS.

VERTICAL PIECE, 2" X 4" X BOX HEIGHT MINUS 3/4" (4 REQD).

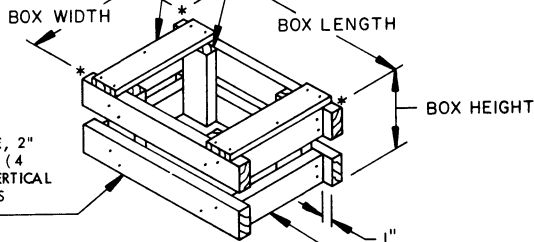

FILLER ASSEMBLY

(FOR MINUS ONE BOX)