

# APPENDIX 44B

## UNITIZATION PROCEDURES FOR BOXED AMMUNITION AND COMPONENTS ON 4-WAY ENTRY PALLETS

CARTRIDGE, 90 MM, BLANK, PACKED 8 PER WOODEN  
BOX, UNITIZED 18 BOXES PER 35" X 45 $\frac{1}{2}$ " PALLET;  
APPROX BOX SIZE 25 $\frac{3}{4}$ " L X 13" W 10 $\frac{1}{4}$ " H

PALLET UNIT DATA						
ITEMS INCLUDED		HAZARD CLASSIFICATION				WEIGHT
NSN	DODIC	DOT CLASS	CG CLASS	QD CLASS	COMP GROUP	(LBS)
1315- 00-542-1639	C261	B	II-B	1.3	C	1,980
00-678-9911	C261	B	II-B	1.3	C	1,980

NOTICE: THIS APPENDIX CANNOT STAND ALONE BUT MUST  
BE USED IN CONJUNCTION WITH THE BASIC UNITIZATION  
PROCEDURES DRAWING 19-48-4116-20PA1002.

REVISIONS				DRAFTSMAN <i>DC/MLK</i>	PROJ ENG <i>2107/MLK</i>
				CHECKER <i>RSW</i>	LOG ENGRG OFFICE <i>John King</i>
APPROVED, U. S. ARMY ARMAMENT MATERIEL READINESS COMMAND					
			<i>Lawrence Kuster</i> <i>DC Fetter</i>		
			DMSAN-MAD      DMSAN-TMD		
APPROVED BY ORDER OF COMMANDING GENERAL, U. S. ARMY MATERIEL DEVELOPMENT AND READINESS COMMAND (DARCOM)					
<i>John L. Reynolds</i>					
U. S. ARMY DEFENSE AMMUNITION CENTER AND SCHOOL					
U. S. ARMY DARCOM DRAWING					
JUNE 1980					
CLASS	DIVISION	DRAWING	FILE		
19	48	4116/44B	20PA 1002		

**DO NOT SCALE**

**GENERAL NOTES**

- A. THIS APPENDIX CANNOT STAND ALONE BUT MUST BE USED IN CONJUNCTION WITH THE BASIC UNITIZATION PROCEDURES DRAWING 19-48-4116-20PA1002. TO PRODUCE AN APPROVED UNIT LOAD, ALL PERTINENT PROCEDURES, SPECIFICATIONS AND CRITERIA SET FORTH WITHIN THE BASIC DRAWING WILL APPLY TO THE PROCEDURES DELINEATED IN THIS APPENDIX. ANY EXCEPTIONS TO THE BASIC PROCEDURES ARE SPECIFIED IN THIS APPENDIX.
- B. DIMENSIONS, CUBE AND WEIGHT OF A PALLET UNIT WILL VARY SLIGHTLY DEPENDING UPON THE ACTUAL DIMENSIONS OF THE BOXES AND THE WEIGHT OF THE SPECIFIC ITEM BEING UNITIZED.
- C. THE LOAD STRAPS MAY BE INSTALLED THROUGH THE STRAP SLOTS OF A PALLET OR PRE-POSITIONED ON THE PALLET DECK PRIOR TO PLACING BOXES ON THE PALLET.
- D. INSTALL EACH TIEDOWN STRAP TO PASS UNDER THE DECK/STRINGER BOARDS OF THE PALLET AND TO BE LOCATED AS SHOWN. TIEDOWN STRAPS WILL BE TENSIONED AND SEALED PRIOR TO LOAD STRAPS.
- E. THE FOLLOWING DARCOM DRAWINGS ARE APPLICABLE FOR UNLOADING AND STORAGE OF THE ITEMS COVERED BY THIS APPENDIX.
 

CARLOADING -----	DRAWING 19-48-4115-5PA1002
TRUCKLOADING -----	DRAWING 19-48-4117-11PA1003
STORAGE -----	DRAWING 19-48-4118-1-2-14-22PA1002
- F. FOR METHOD OF SECURING A STRAP CUTTER TO THE PALLET UNIT, SEE DARCOM DRAWING 19-48-4127-20P1000.
- G. IF ITEMS COVERED HEREIN ARE UNITIZED PRIOR TO ISSUANCE OF THIS APPENDIX, THE BOXES NEED NOT BE REUNITIZED SOLELY TO CONFORM TO THIS APPENDIX.
- H. THE UNITIZATION PROCEDURES DEPICTED HEREIN MAY ALSO BE USED FOR UNITIZING 90MM CARTRIDGES WHEN IDENTIFIED BY DIFFERENT NATIONAL STOCK NUMBERS (NSN) THAN WHAT IS SHOWN ON THE TITLE PAGE, PROVIDED THE BOX PACK DOES NOT VARY FROM WHAT IS DELINEATED HEREIN. THE EXPLOSIVE CLASSIFICATION OF OTHER ITEMS MAY BE DIFFERENT THAN WHAT IS SHOWN.

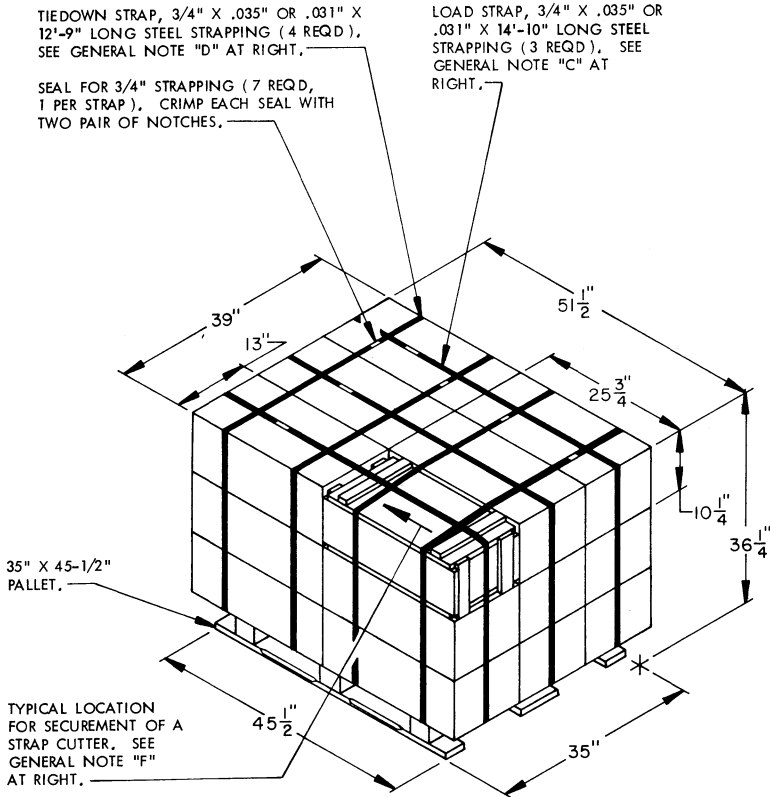

**PALLET UNIT**

SEE GENERAL NOTE "B" AT RIGHT.

18 BOXES OF 90MM CARTRIDGE (8 PER BOX) @ 106 LBS -----	1,908 LBS (APPROX)
DUNNAGE -----	7 LBS
PALLET -----	65 LBS
TOTAL WEIGHT -----	1,980 LBS (APPROX)
CUBE -----	42.1 CU FT (APPROX)

**BILL OF MATERIAL**

PALLET, 35" X 45-1/2" -----	1 REQD -----	65 LBS
STEEL STRAPPING, 3/4" -----	95.50' REQD -----	6.82 LBS
SEAL FOR 3/4" STRAPPING -----	7 REQD -----	NIL

TIE PIECE, 1" X 4" X BOX WIDTH (2 REQD).  
NAIL TO LONGITUDINAL PIECES W/2-6d  
NAILS AT EACH END AND TO LATERAL PIECE  
W/2-6d NAILS.

VERTICAL PIECE, 2" X 4"  
X BOX HEIGHT MINUS  
3/4" (4 REQD).

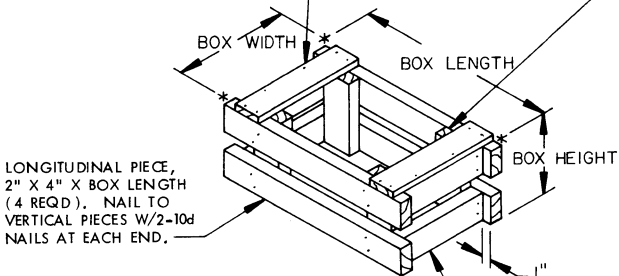

**FILLER ASSEMBLY**

(FOR MINUS ONE BOX)