

# APPENDIX 44

## UNITIZATION PROCEDURES FOR BOXED AMMUNITION AND COMPONENTS ON 4-WAY ENTRY PALLETS

90MM CARTRIDGE, PACKED TWO PER WOODEN  
BOX, UNITIZED 16 BOXES PER 40" X 48" PALLET;  
APPROX BOX SIZE 43 <sup>5</sup>/<sub>8</sub>" L X 13" W X 8 <sup>5</sup>/<sub>32</sub>" H

PALLET UNIT DATA						
ITEMS INCLUDED		HAZARD CLASSIFICATION <sup>①</sup>				WEIGHT (LBS)
NSN	DODIC	DOT CLASS	CG CLASS	QD CLASS	COMP GROUP	
1315-						
00-028-4411	C267	A	IV	(12)1.2	E	2,087
00-028-4412	C266	A	IV	(12)1.2	E	2,199
00-028-4413	C266	A	IV	(12)1.2	E	2,199
00-028-4415	C266	A	IV	(12)1.2	E	2,199
00-028-4417	C267	A	IV	(12)1.2	E	2,199
00-028-4418	C267	A	IV	(12)1.2	E	2,199
00-028-4422	C267	A	IV	(12)1.2	E	2,087
00-028-4424	C260	A	IV	(08)1.2	E	2,183
00-028-4427	C266	A	IV	(12)1.2	E	2,199
00-028-4428	C266	A	IV	(12)1.2	E	2,199
00-028-4430	C267	A	IV	(12)1.2	E	1,975
00-028-4432	C267	A	IV	(12)1.2	E	2,199
00-028-4433	C267	A	IV	(12)1.2	E	2,199
00-028-4438	C265	A	IV	(12)1.2	E	2,199
00-028-4445	C265	A	IV	(12)1.2	E	2,199
00-028-4453	C266	A	IV	(12)1.2	E	2,199
00-028-4455	C266	A	IV	(12)1.2	E	2,199
00-028-4458	C267	A	IV	(12)1.2	E	2,087
00-028-4468	C265	A	IV	(12)1.2	E	2,199
00-028-4478	C266	A	IV	(12)1.2	E	2,199
00-028-4481	C266	A	IV	(12)1.2	E	2,199
00-028-4484	C265	A	IV	(12)1.2	E	2,199
00-028-4507	C263	----- INERT -----				2,087
00-028-4741	C285	B	II-B	(08)1.2	C	2,191
00-028-4742	C285	B	II-B	(08)1.2	C	2,191
00-028-4746	C287	A	IV	(12)1.2	E	2,023

NSN	DODIC	DOT CLASS	CG CLASS	QD CLASS	COMP GROUP	WEIGHT (LBS)
00-057-9576	C280	A	IV	(12)1.2	E	2,151
00-057-9577	C280	A	IV	(12)1.2	E	2,151
00-301-1745	C265	A	IV	(12)1.2	E	2,199
00-324-1412	C290	B	II-B	(08)1.2	C	2,151
00-678-6114	C294	A	IV	(12)1.2	E	1,831
00-682-4758	C266	A	IV	(12)1.2	E	2,199
00-682-4759	C266	A	IV	(12)1.2	E	2,199
00-727-3637	C280	A	IV	(12)1.2	E	2,199
00-752-7574	C280	A	IV	(12)1.2	E	2,151
00-752-7575	C280	A	IV	(12)1.2	E	2,151
00-892-4236	C280	A	IV	(12)1.2	E	2,151
00-892-4928	C266	A	IV	(12)1.2	E	2,199
00-926-1885	C280	A	IV	(12)1.2	E	2,199
00-926-1888	C280	A	IV	(12)1.2	E	2,199
00-926-1889	C280	A	IV	(12)1.2	E	2,199
00-926-1928	C601	B	II - B	(08)1.2	C	1,975
00-965-0660	C280	A	IV	(12)1.2	E	2,151
00-965-0661	C280	A	IV	(12)1.2	E	2,151
00-965-0674	C266	A	IV	(12)1.2	E	2,199
00-965-0675	C266	A	IV	(12)1.2	E	2,199
00-965-0783	C290	B	II - B	(08)1.2	C	2,183
00-965-0784	C290	B	II - B	(08)1.2	C	2,183
00-965-0838	C280	A	IV	(12)1.2	E	2,151
00-926-3974	C285	B	II - B	(08)1.2	C	2,183

NOTICE: THIS APPENDIX CANNOT STAND ALONE BUT MUST BE USED IN CONJUNCTION WITH THE BASIC UNITIZATION PROCEDURES DRAWING 19-48-4116-20PA1002.

THIS APPENDIX SUPERSEDES INTERIM DRAWING 19-48-4139-20PA1001, DATED NOVEMBER 1976.

① HAZARD CLASSIFICATION DATA CONTAINED IN THE ABOVE CHART IS FOR GUIDANCE AND INFORMATIONAL PURPOSES ONLY. VERIFICATION OF THE SPECIFIED DATA SHOULD BE MADE BY CONSULTING THE MOST RECENT JOINT HAZARD CLASSIFICATION SYSTEM LISTING OR OTHER APPROVED LISTING(S).

**DO NOT SCALE**

REVISIONS			DRAFTSMAN GRG/PRK	PROJ ENG A/WD/JNW
1	MAR 78	<i>John S. Fetter</i> DRSM - MAD	<i>John S. Fetter</i> DRSM - TMD	<i>John S. Fetter</i> LOC ENGNG OFFICER
2	NOV 83	<i>John S. Fetter</i> DRSM - LEP	<i>John S. Fetter</i> DRSM - TMD	<i>John S. Fetter</i> DRSM - TMA
APPROVED BY ORDER OF COMMANDING GENERAL, U.S. ARMY MATERIAL DEVELOPMENT AND READINESS COMMAND (DARCOM)				
<i>A. S. Chodura</i> DARCOM AMMO CENTER				
U. S. ARMY DARCOM DRAWING				
FEBRUARY 1977				
	CLASS	DIVISION	DRAWING	FILE
	19	48	4116/44	20PA 1002

SEAL FOR 3/4" STRAPPING (6 REQD, 1 PER STRAP), CRIMP EACH SEAL WITH TWO PAIR OF NOTCHES.

LOAD STRAP, 3/4" X .035" OR .031" X 15'-3" LONG STEEL STRAPPING (2 REQD). SEE GENERAL NOTE "C" AT RIGHT.

TIEDOWN STRAP, 3/4" X .035" OR .031" X 13'-10" LONG STEEL STRAPPING (4 REQD). SEE GENERAL NOTE "D" AT RIGHT.

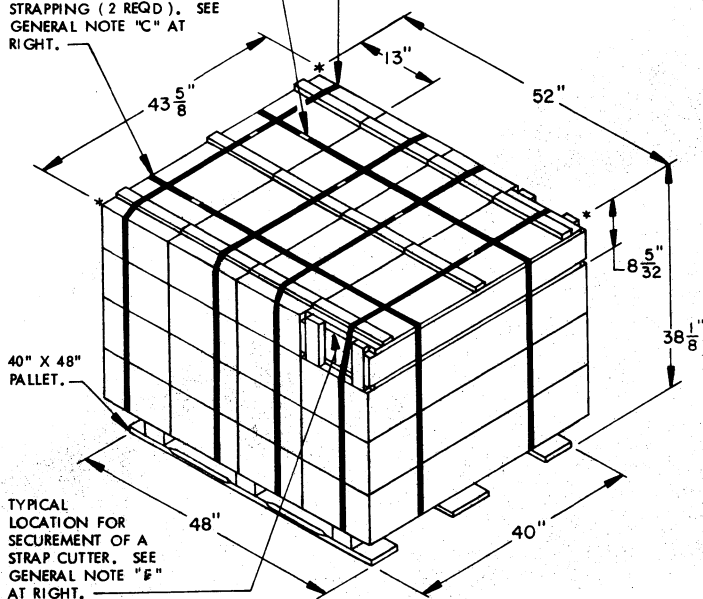

**PALLET UNIT**

SEE GENERAL NOTE "B" AT RIGHT.

16 BOXES OF 90MM CARTRIDGE (2 PER BOX) @ 132 LBS	-----	2,112 LBS (APPROX)
DUNNAGE	-----	7 LBS
PALLET	-----	80 LBS
TOTAL WEIGHT	-----	2,199 LBS (APPROX)
CUBE	-----	50.1 CU FT (APPROX)

**GENERAL NOTES**

- A. THIS APPENDIX CANNOT STAND ALONE BUT MUST BE USED IN CONJUNCTION WITH THE BASIC UNITIZATION PROCEDURES DRAWING 19-48-4116-20PA1002. TO PRODUCE AN APPROVED UNIT LOAD, ALL PERTINENT PROCEDURES, SPECIFICATIONS AND CRITERIA SET FORTH WITHIN THE BASIC DRAWING WILL APPLY TO THE PROCEDURES DELINEATED IN THIS APPENDIX. ANY EXCEPTIONS TO THE BASIC PROCEDURES ARE SPECIFIED IN THIS APPENDIX.
- B. DIMENSIONS, CUBE AND WEIGHT OF A PALLET UNIT WILL VARY SLIGHTLY DEPENDING UPON THE ACTUAL DIMENSIONS OF THE BOXES AND THE WEIGHT OF THE SPECIFIC ITEM BEING UNITIZED.
- C. THE LOAD STRAPS WILL BE THREADED THROUGH THE STRAP SLOTS OF THE PALLET. LOAD STRAPS MUST BE TENSIONED AND SEALED PRIOR TO APPLICATION OF TIEDOWN STRAPS.
- D. INSTALL EACH TIEDOWN STRAP TO PASS UNDER THE DECK/STRINGER BOARDS OF THE PALLET AND TO BE LOCATED BETWEEN THE VERTICAL END CLEATS OF THE BOXES. TIEDOWN STRAPS WILL NOT BE APPLIED UNTIL THE LOAD STRAPS HAVE BEEN TENSIONED AND SEALED.
- E. THE FOLLOWING DARCOM DRAWINGS ARE APPLICABLE FOR OUTLOADING AND STORAGE OF THE ITEMS COVERED BY THIS APPENDIX.
 

CARLOADING	-----	DRAWING 19-48-4115-5PA1002
TRUCKLOADING	-----	DRAWING 19-48-4117-11PA1003
STORAGE	-----	DRAWING 19-48-4118-1-2-3-4-14-22PA1002
- F. FOR METHOD OF SECURING A STRAP CUTTER TO THE PALLET UNIT, SEE DARCOM DRAWING 19-48-4127-20P1000.
- G. IF ITEMS COVERED HEREIN ARE UNITIZED PRIOR TO ISSUANCE OF THIS APPENDIX, THE BOXES NEED NOT BE REUNITIZED SOLELY TO CONFORM TO THIS APPENDIX.
- H. THE UNITIZATION PROCEDURES DEPICTED HEREIN MAY ALSO BE USED FOR UNITIZING 90MM CARTRIDGES WHEN IDENTIFIED BY A DIFFERENT NATIONAL STOCK NUMBER (NSN) THAN WHAT IS SHOWN ON THE TITLE PAGE, PROVIDED THE BOX PACK DOES NOT VARY FROM WHAT IS DELINEATED HEREIN. THE EXPLOSIVE CLASSIFICATION OF OTHER ITEMS MAY BE DIFFERENT THAN WHAT IS SHOWN.

**REVISIONS**

- REVISION NO. 1, DATED MARCH 1978, CONSISTS OF:
1. ADDING ELEVEN ( 11 ) MORE ITEMS BY NATIONAL STOCK NUMBER TO THE "PALLET UNIT DATA" CHART.
  2. CHANGED ISOMETRIC VIEW TO CURRENT CONFIGURATION.
- REVISION NO. 2, DATED NOVEMBER 1983, CONSISTS OF:
1. DELETING TWO ITEMS BY NATIONAL STOCK NUMBER FROM "PALLET UNIT DATA" CHART.
  2. UPDATING STORAGE DRAWING NUMBER.

BILL OF MATERIAL		
PALLET, 40" X 48"	1 REQD	80 LBS
STEEL STRAPPING, 3/4"	55.83' REQD	6.13 LBS
SEAL FOR 3/4" STRAPPING	6 REQD	NIL

