

APPENDIX 43Q

UNITIZATION PROCEDURES FOR BOXED AMMUNITION AND COMPONENTS ON 4-WAY ENTRY PALLETS

REFURBISHMENT KIT FOR PRACTICE CARTRIDGES,
60MM AND 81MM PACKED 100 PER WIREBOUND BOX
UNITIZED 8 BOXES PER 42" X 53" PALLET;
APPROX BOX SIZE 41" L X 20-1/4" W X
14-5/8" H

NOTICE: THIS APPENDIX CANNOT STAND ALONE BUT MUST BE USED IN CONJUNCTION WITH
THE BASIC UNITIZATION PROCEDURES DRAWING 19-48-4116-20PA1002.

DISTRIBUTION STATEMENT A.

APPROVED FOR PUBLIC RELEASE;
DISTRIBUTION IS UNLIMITED.

U.S. ARMY MATERIEL COMMAND DRAWING					
APPROVED, U.S. ARMY ARMAMENT, MUNITIONS AND CHEMICAL COMMAND <i>David A. Robert</i> SMCAR-ESK	APPROVED, U.S. ARMY ARMAMENT, MUNITIONS AND CHEMICAL COMMAND <i>David E. Hoober</i> AMSMC-TMJ	DRAFTSMAN ENGINEER	BETTY J. KUNDERT SANDRA M. SCHULTZ		
APPROVED BY ORDER OF COMMANDING GENERAL, U.S. ARMY MATERIEL COMMAND <i>William F Ernst</i> U.S. ARMY DEFENSE AMMUNITION CENTER AND SCHOOL		SUPPLY ENGINEERING DIVISION <i>R. J. Michels</i>	TRANSPORTATION ENGINEERING DIVISION <i>W. J. ...</i>	VALIDATION ENGINEERING DIVISION <i>J. ...</i>	
APPROVED BY ORDER OF COMMANDING GENERAL, U.S. ARMY MATERIEL COMMAND <i>William F Ernst</i> U.S. ARMY DEFENSE AMMUNITION CENTER AND SCHOOL		LOGISTICS ENGINEERING OFFICE <i>William F Ernst</i> MAY 1994			
U.S. ARMY DEFENSE AMMUNITION CENTER AND SCHOOL		CLASS	DIVISION	DRAWING	FILE
U.S. ARMY DEFENSE AMMUNITION CENTER AND SCHOOL		19	48	4116/ 430	20PA 1002

DO NOT SCALE

PALLET UNIT DATA				
ITEMS INCLUDED		HAZARD CLASS AND DIVISION ●		APPROX WEIGHT LBS
NSN	DODIC	OD CLASS	COMP GROUP	
1315-01-219-3936	C045	1.4	G	1,114

- HAZARD CLASSIFICATION DATA CONTAINED IN THE ABOVE CHART IS FOR GUIDANCE AND INFORMATIONAL PURPOSES ONLY. VERIFICATION OF THE SPECIFIED DATA SHOULD BE MADE BY CONSULTING THE MOST RECENT JOINT HAZARD CLASSIFICATION SYSTEM LISTING OR OTHER APPROVED LISTING(S).

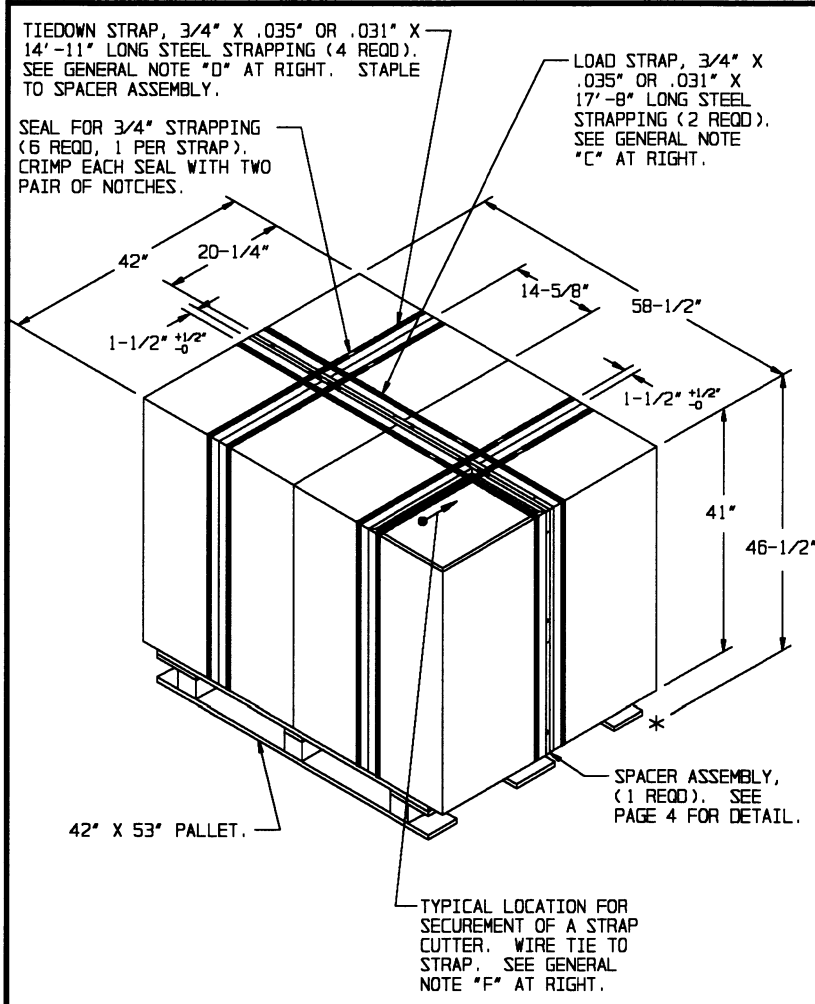

GENERAL NOTES

- A. THIS APPENDIX CANNOT STAND ALONE BUT MUST BE USED IN CONJUNCTION WITH THE BASIC UNITIZATION PROCEDURES DRAWING 19-48-4116-20PA1002. TO PRODUCE AN APPROVED UNIT LOAD, ALL PERTINENT PROCEDURES, SPECIFICATIONS AND CRITERIA SET FORTH WITHIN THE BASIC DRAWING WILL APPLY TO THE PROCEDURES DELINEATED IN THIS APPENDIX. ANY EXCEPTIONS TO THE BASIC PROCEDURES ARE SPECIFIED IN THIS APPENDIX.
- B. DIMENSIONS, CUBE AND WEIGHT OF A PALLET UNIT WILL VARY SLIGHTLY DEPENDING UPON THE ACTUAL DIMENSIONS OF THE BOXES AND THE WEIGHT OF THE SPECIFIC ITEM BEING UNITIZED.
- C. THE LOAD STRAPS MUST BE PRE-POSITIONED ON THE PALLET DECK PRIOR TO PLACING BOXES ON THE PALLET. NOTE THAT THE LOAD STRAPS WILL BE LOCATED AS SHOWN. LOAD STRAPS MUST BE TENSIONED AND SEALED PRIOR TO APPLICATION OF TIEDOWN STRAPS.
- D. INSTALL EACH TIEDOWN STRAP TO PASS UNDER THE TOP DECK BOARDS OF THE PALLET. NOTE THAT THE STRAPS WILL BE LOCATED AS SHOWN, NEAR THE SIDE CLEATS OF THE END PANELS OF THE BOX. TIEDOWN STRAPS WILL NOT BE APPLIED UNTIL THE LOAD STRAPS HAVE BEEN TENSIONED AND SEALED.
- E. THE FOLLOWING AMC DRAWINGS ARE APPLICABLE FOR UNLOADING AND STORAGE OF THE ITEMS COVERED BY THIS APPENDIX.
 - CARLOADING - - - - 19-48-4115-5PA1002
 - TRUCKLOADING - - - - 19-48-4117-11PA1003
 - STORAGE - - - - - 19-48-4118-1-2-3-4-14-22PA1002
 - END OPENING ISO CONTAINER - - - - 19-48-4153-15PA1002
 - MILVAN - - - - - 19-48-4166-15PA1003
 - SIDE OPENING ISO CONTAINER - - - - 19-48-4267-15PA1009
- F. FOR METHOD OF SECURING A STRAP CUTTER TO THE PALLET UNIT, SEE AMC DRAWING 19-48-4127-20P1000.
- G. IF ITEMS COVERED HEREIN ARE UNITIZED PRIOR TO ISSUANCE OF THIS APPENDIX, THE BOXES NEED NOT BE REUNITIZED SOLELY TO CONFORM TO THIS APPENDIX.
- H. THE UNITIZATION PROCEDURES DEPICTED HEREIN MAY ALSO BE USED FOR UNITIZING REFURBISHMENT KITS WHEN IDENTIFIED BY DIFFERENT NATIONAL STOCK NUMBERS (NSN) THAN WHAT IS SHOWN ON PAGE 2, PROVIDED THE BOX PACK DOES NOT VARY FROM WHAT IS DELINEATED HEREIN. THE EXPLOSIVE CLASSIFICATION OF OTHER ITEMS MAY BE DIFFERENT THAN WHAT IS SHOWN.
- J. THE STYLE 1B PALLET DELINEATED IN THE DETAIL AT LEFT NEED NOT HAVE CHAMFERS OR STRAP SLOTS AS SPECIFIED WITHIN MILITARY SPECIFICATION MIL-P-15011 WHEN USED FOR THE UNITIZATION OF ITEMS COVERED BY THIS APPENDIX.
- K. TIEDOWN AND LOAD STRAPS MUST BE LOCATED 1-1/2" (NOT TO EXCEED 2") FROM THE SIDE OF THE BOX.
- L. THE WIREBOUND BOX DRAWING NUMBER IS 12944149.

PALLET UNIT

8 BOXES OF REFURBISHMENT KITS AT 125 LBS	-----	1,000 LBS (APPROX)
DUNNAGE	-----	24 LBS
PALLET	-----	90 LBS
TOTAL WEIGHT	-----	1,114 LBS (APPROX)
CUBE	-----	66.12 CU FT (APPROX)

BILL OF MATERIAL		
LUMBER	LINEAR FEET	BOARD FEET
1" X 4"	24.88	8.29
NAILS	NO. REQD	POUNDS
6d(2")	27	0.16
PALLET, 42" X 53"	----- 1 REQD	----- 90 LBS
STEEL STRAPPING, 3/4"	----- 95.00' REQD	----- 6.79 LBS
SEAL FOR 3/4" STRAPPING	----- 6 REQD	----- NIL
STRAP STAPLE (15/16" X 3/4")	----- 4 REQD	----- NIL

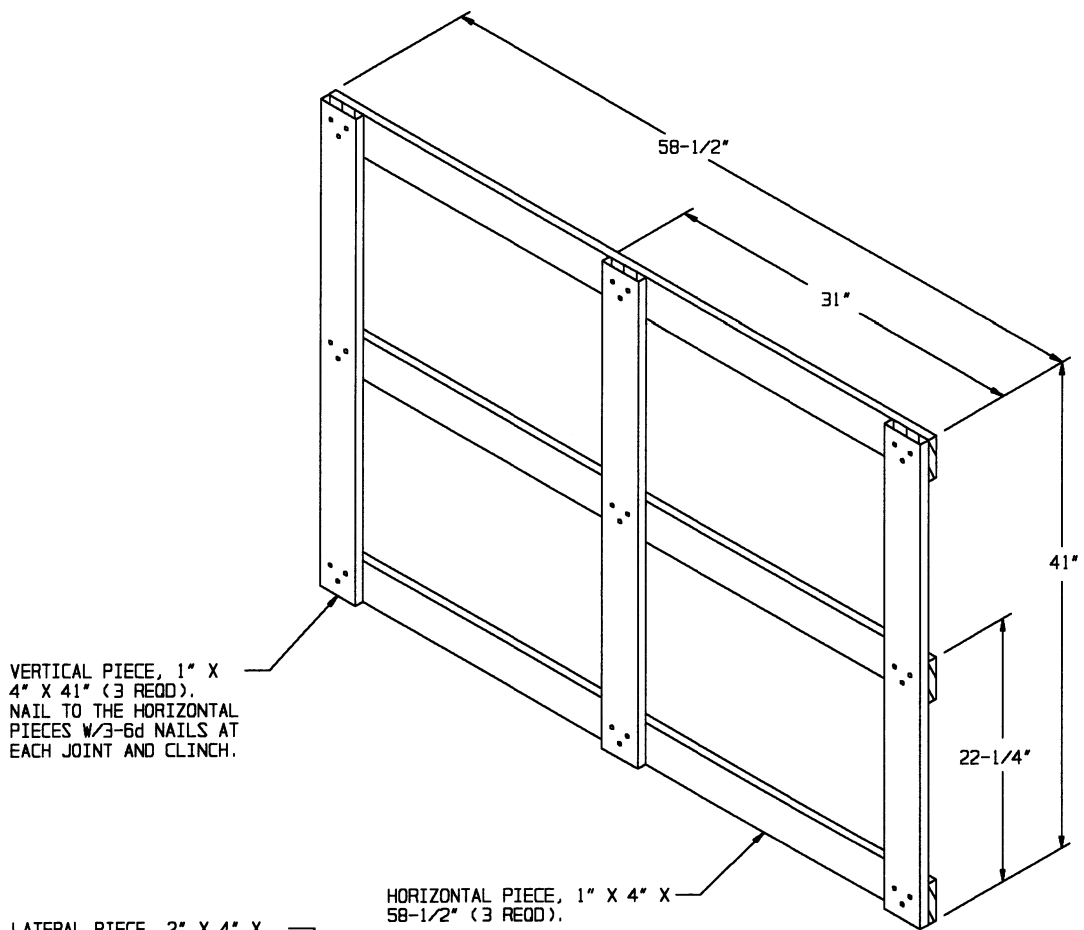

SPACER ASSEMBLY
(1 REQD)

