

# APPENDIX 43L

## UNITIZATION PROCEDURES FOR BOXED AMMUNITION AND COMPONENTS ON 4-WAY ENTRY PALLET

**CARTRIDGE, IGNITER, M752, FOR 81MM  
M819/M853, PACKED 192 PER WIREBOUND  
BOX, UNITIZED 8 BOXES PER 35" X 45-1/2"  
PALLET; APPROX BOX SIZE 23-3/8" L X  
17-3/8" W X 18-5/8" H**

**NOTICE: THIS APPENDIX CANNOT STAND ALONE BUT MUST BE USED IN CONJUNCTION WITH  
THE BASIC UNITIZATION PROCEDURES DRAWING 19-48-4116-20PA1002.**

**DISTRIBUTION STATEMENT A:**

**APPROVED FOR PUBLIC RELEASE;  
DISTRIBUTION IS UNLIMITED.**

### U.S. ARMY MATERIEL COMMAND DRAWING

<p style="font-size: small;">APPROVED, U.S. ARMY OPERATIONS SUPPORT COMMAND</p> <p style="font-size: x-small;">AMSTA-AR-WEP-RP</p> <p style="font-size: x-small;">MSOS-TM</p> <p style="font-size: x-small;">APPROVED BY ORDER OF COMMANDING GENERAL, U.S. ARMY MATERIEL COMMAND</p> <p style="font-size: x-small;">U.S. ARMY DEFENSE AMMUNITION CENTER</p>	<p style="text-align: center;"><b>CAUTION: VERIFY PRIOR TO USE AT WWW.DAC.ARMY.MIL/DET THAT THIS IS THE MOST CURRENT VERSION OF THIS DOCUMENT. THIS IS PAGE 1 OF 4.</b></p> <table border="1" style="width: 100%; border-collapse: collapse;"> <tr> <td colspan="2" style="text-align: center;"><b>DO NOT SCALE</b></td> <td colspan="2" style="text-align: center;"><b>OCTOBER 1988</b></td> </tr> <tr> <td style="font-size: x-small;">ENGINEER OR TECHNICIAN</td> <td style="font-size: x-small;">BASIC REV.</td> <td style="font-size: x-small;">SANDRA SCHULTZ</td> <td style="font-size: x-small;">RANDIE UNSER</td> </tr> <tr> <td colspan="2" style="font-size: x-small;">TRANSPORTATION ENGINEERING DIVISION</td> <td colspan="2" style="font-size: x-small;">REVISION NO. 1    SEPTEMBER 2002</td> </tr> <tr> <td colspan="4" style="text-align: center; font-size: x-small;">SEE THE REVISION LISTING ON PAGE 2</td> </tr> <tr> <td style="font-size: x-small;">VALIDATION ENGINEERING DIVISION</td> <td style="font-size: x-small;">TESTED</td> <td style="font-size: x-small;">CLASS</td> <td style="font-size: x-small;">DIVISION</td> </tr> <tr> <td style="font-size: x-small;">ENGINEERING DIRECTORATE</td> <td style="font-size: x-small;">TESTED</td> <td style="font-size: x-small;">DRAWING</td> <td style="font-size: x-small;">FILE</td> </tr> <tr> <td colspan="2"></td> <td style="text-align: center;">19</td> <td style="text-align: center;">48</td> </tr> <tr> <td colspan="2"></td> <td style="text-align: center;">4116/ 43L</td> <td style="text-align: center;">20PA1002</td> </tr> </table>	<b>DO NOT SCALE</b>		<b>OCTOBER 1988</b>		ENGINEER OR TECHNICIAN	BASIC REV.	SANDRA SCHULTZ	RANDIE UNSER	TRANSPORTATION ENGINEERING DIVISION		REVISION NO. 1    SEPTEMBER 2002		SEE THE REVISION LISTING ON PAGE 2				VALIDATION ENGINEERING DIVISION	TESTED	CLASS	DIVISION	ENGINEERING DIRECTORATE	TESTED	DRAWING	FILE			19	48			4116/ 43L	20PA1002
<b>DO NOT SCALE</b>		<b>OCTOBER 1988</b>																															
ENGINEER OR TECHNICIAN	BASIC REV.	SANDRA SCHULTZ	RANDIE UNSER																														
TRANSPORTATION ENGINEERING DIVISION		REVISION NO. 1    SEPTEMBER 2002																															
SEE THE REVISION LISTING ON PAGE 2																																	
VALIDATION ENGINEERING DIVISION	TESTED	CLASS	DIVISION																														
ENGINEERING DIRECTORATE	TESTED	DRAWING	FILE																														
		19	48																														
		4116/ 43L	20PA1002																														

PALLET UNIT DATA				
ITEMS INCLUDED		● HAZARD CLASS AND DIVISION	● COMPAT- ABILITY GROUP	APPROX WEIGHT LBS
NSN	DODIC			
1315-01-290-4748	—	1. 4	G	609

● HAZARD CLASSIFICATION DATA CONTAINED IN THE ABOVE CHART IS FOR GUIDANCE AND INFORMATIONAL PURPOSES ONLY. VERIFICATION OF THE SPECIFIED DATA SHOULD BE MADE BY CONSULTING THE MOST RECENT JOINT HAZARD CLASSIFICATION SYSTEM LISTING OR OTHER APPROVED LISTING(S).

### REVISION

REVISION NO. 1, DATED SEPTEMBER 2002, CONSISTS OF:

1. ADDING NATIONAL STOCK NUMBER TO THE PALLET UNIT DATA CHART.
2. UPDATING GENERAL NOTES.
3. UPDATING DRAWING FORMAT.

**GENERAL NOTES**

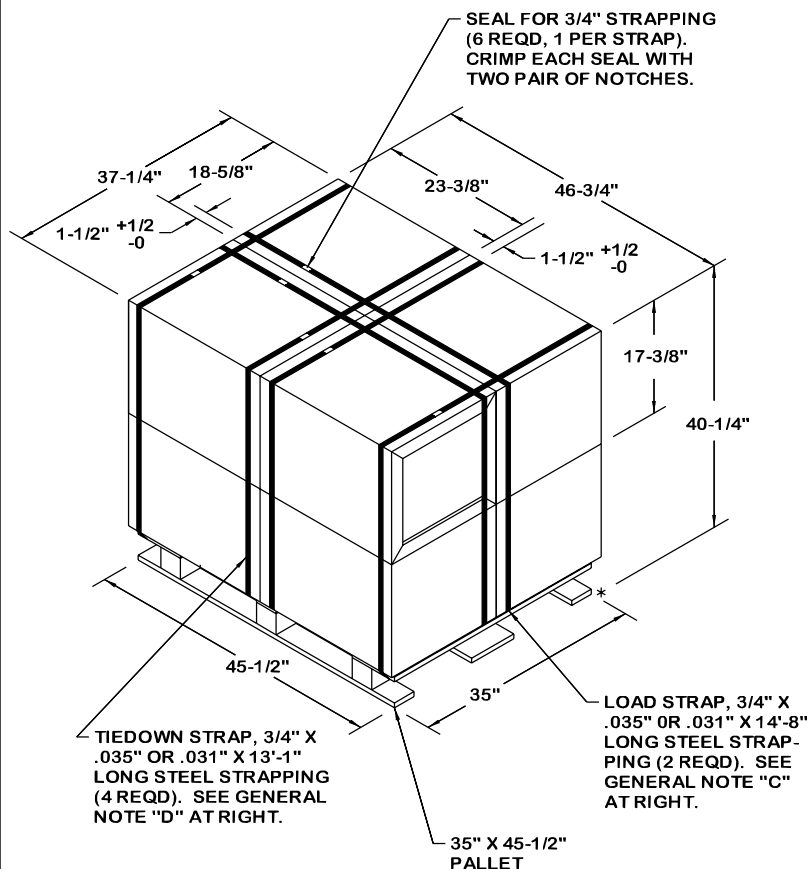

**PALLET UNIT**

SEE GENERAL NOTE "B" AT RIGHT

8 BOXES OF IGNITER CARTRIDGES (192 PER BOX) @ 67 LBS - - - 536 LBS (APPROX)  
 DUNNAGE - - - - - 8 LBS  
 PALLET - - - - - 65 LBS

TOTAL WEIGHT - - - - - 609 LBS (APPROX)  
 CUBE - - - - - 40.6 CU FT (APPROX)

BILL OF MATERIAL			
PALLET, 35" X 45-1/2"	- - - - - 1 REQD	- - -	65 LBS
STEEL STRAPPING, 3/4"	- - - 81.67' REQD	- - -	7.29 LBS
SEAL FOR 3/4" STRAPPING	- - - - 6 REQD	- - -	NIL

- A. THIS APPENDIX CANNOT STAND ALONE BUT MUST BE USED IN CONJUNCTION WITH THE BASIC UNITIZATION PROCEDURES DRAWING 19-48-4116-20PA1002. TO PRODUCE AN APPROVED UNIT LOAD, ALL PERTINENT PROCEDURES, SPECIFICATIONS AND CRITERIA SET FORTH WITHIN THE BASIC DRAWING WILL APPLY TO THE PROCEDURES DELINEATED IN THIS APPENDIX. ANY EXCEPTIONS TO THE BASIC PROCEDURES ARE SPECIFIED IN THIS APPENDIX.
- B. DIMENSIONS, CUBE AND WEIGHT OF A PALLET UNIT WILL VARY SLIGHTLY DEPENDING UPON THE ACTUAL DIMENSIONS OF THE BOXES AND THE WEIGHT OF THE SPECIFIC ITEM BEING UNITIZED.
- C. THE LOAD STRAPS MUST BE PRE-POSITIONED ON THE PALLET DECK PRIOR TO PLACING BOXES ON THE PALLET. NOTE THAT THE LOAD STRAPS WILL BE LOCATED AS SHOWN. LOAD STRAPS MUST BE TENSIONED AND SEALED PRIOR TO APPLICATION OF TIEDOWN STRAPS.
- D. INSTALL EACH TIEDOWN STRAP TO PASS UNDER THE DECK/STRINGER BOARDS OF THE PALLET AND TO BE LOCATED AS SHOWN. TIEDOWN STRAPS WILL NOT BE APPLIED UNTIL THE LOAD STRAPS HAVE BEEN TENSIONED AND SEALED.
- E. THE FOLLOWING AMC DRAWINGS ARE APPLICABLE FOR OUTLOADING AND STORAGE OF THE ITEMS COVERED BY THIS APPENDIX.
  - CARLOADING - - - - 19-48-4115-5PA1002
  - TRUCKLOADING - - - - 19-48-4117-11PA1003
  - STORAGE - - - - - 19-48-4118-1-2-3-4-14-22PA1002
  - END OPENING ISO CONTAINER - - - - 19-48-4153-15PA1002
  - MILVAN - - - - - 19-48-4166-15PA1003
  - SIDE OPENING ISO CONTAINER - - - - 19-48-4267-15PA1009
- F. IF ITEMS COVERED HEREIN ARE UNITIZED PRIOR TO ISSUANCE OF THIS REVISION TO THIS APPENDIX, THE BOXES NEED NOT BE REUNITIZED SOLELY TO CONFORM TO THIS REVISION.
- G. THE UNITIZATION PROCEDURES DEPICTED HEREIN MAY ALSO BE USED FOR UNITIZING IGNITER CARTRIDGES WHEN IDENTIFIED BY DIFFERENT NATIONAL STOCK NUMBERS (NSN) THAN WHAT IS SHOWN ON PAGE 2, PROVIDED THE BOX PACK DOES NOT VARY FROM WHAT IS DELINEATED HEREIN. THE EXPLOSIVE CLASSIFICATION OF OTHER ITEMS MAY BE DIFFERENT THAN WHAT IS SHOWN.
- H. THE STYLE 1A PALLET DELINEATED IN THE DETAIL AT LEFT NEED NOT HAVE CHAMFERS OR STRAP SLOTS AS SPECIFIED WITHIN MILITARY SPECIFICATION MIL-P-15011 WHEN USED FOR THE UNITIZATION OF ITEMS COVERED BY THIS APPENDIX.
- J. FOR DETAILS OF THE WIREBOUND BOX SEE DRAWING 9294951.

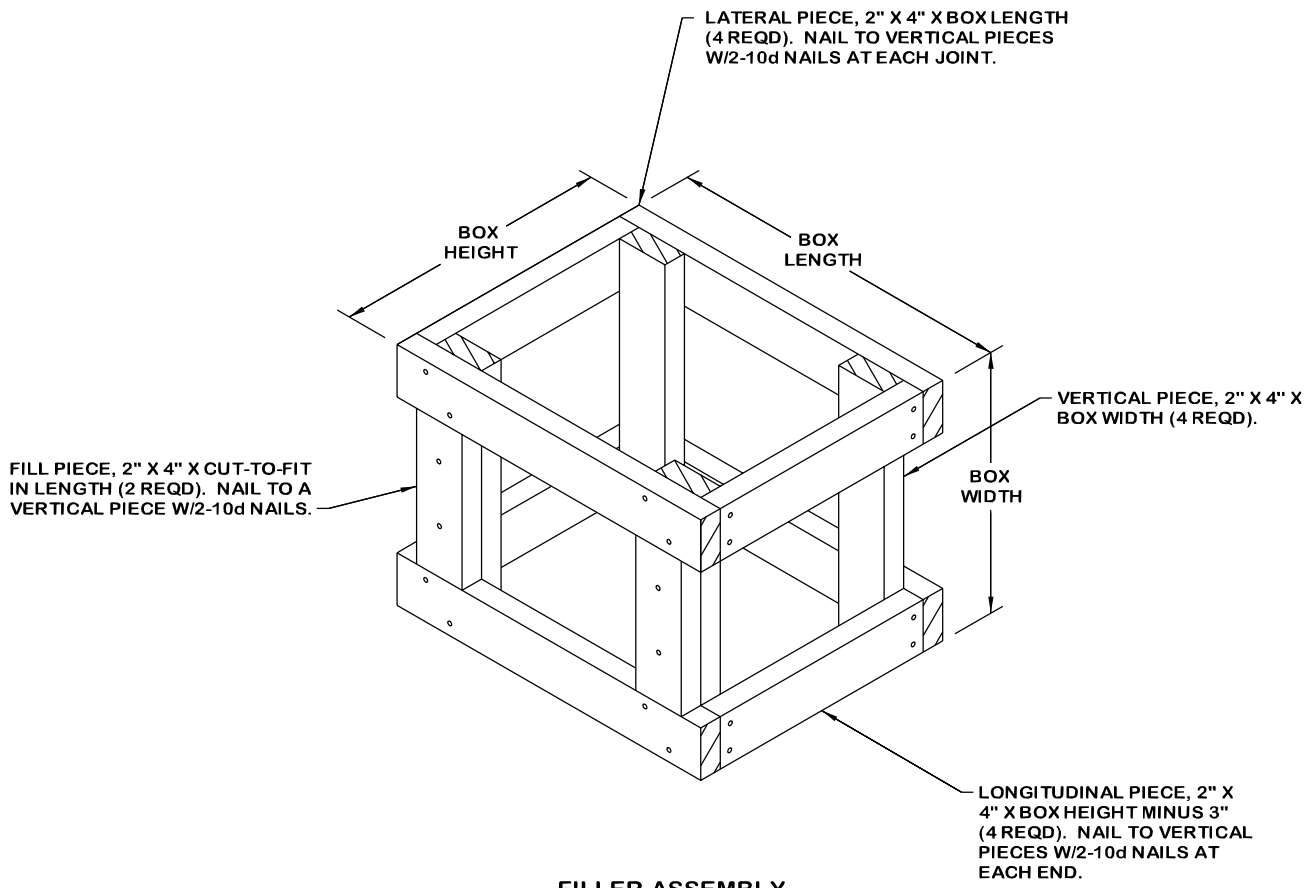

**FILLER ASSEMBLY**  
 (FOR MINUS ONE BOX)