

## APPENDIX 43B

# UNITIZATION PROCEDURES FOR BOXED AMMUNITION AND COMPONENTS ON 4-WAY ENTRY PALLETS

CARTRIDGE, 81MM, ILLUMINATING, PACKED 4  
PER WIREBOUND BOX, UNITIZED 30 BOXES  
PER 40" X 48" PALLET; APPROX BOX SIZE  
30 $\frac{1}{8}$ " L X 8 $\frac{1}{2}$ " W X 8 $\frac{1}{4}$ " H

PALLET UNIT DATA						
ITEMS INCLUDED		HAZARD CLASSIFICATION				WEIGHT
NSN	DODIC	DOT CLASS	CG CLASS	QD CLASS	COMP GROUP	(LBS)
1315-00-926-3927	C251	A	IV	(08) 1.2	G	1,618

**NOTICE:** THIS APPENDIX CANNOT STAND ALONE BUT MUST BE USED IN CONJUNCTION WITH THE BASIC UNITIZATION PROCEDURES DRAWING 19-48-4116-20PA1002.

REVISIONS				DRAWN BY <i>RSH</i>	PROJ. ENG. <i>RSH</i>
				CHECKED <i>RSH</i>	LOG ENGINE OFFICE <i>John Boyd</i>
				APPROVED, U. S. ARMY ARMAMENT MATERIEL READINESS COMMAND	
				<i>Lawrence Kuster</i>	<i>D. P. Feltner</i>
				DRBAR-MAD	DRBAR-TMO
				APPROVED BY ORDER OF COMMANDING GENERAL, U. S. ARMY MATERIEL DEVELOPMENT AND READINESS COMMAND (DARCOM)	
				<i>John L. Boyd</i>	
				U. S. ARMY DEFENSE ACQUISITION CENTER AND SERVIC	
				U. S. ARMY DARCOM DRAWING	
				JUNE 1980	
				CLASS	DIVISION
				DRAWING	FILE
				19	48
				4116/43B	20PA 1002

**DO NOT SCALE**

SEAL FOR 3/4" STRAPPING  
( 8 REQ'D, 1 PER STRAP ).  
CRIMP EACH SEAL WITH TWO  
PAIR OF NOTCHES.

TIEDOWN STRAP, 3/4" X .035" OR .031"  
X 13'-0" LONG STEEL STRAPPING ( 6  
REQ'D ). SEE GENERAL NOTE "D" AT  
RIGHT.

HORIZONTAL STRAP,  
3/4" X .035" OR .031"  
X 16'-5" LONG STEEL  
STRAPPING ( 2 REQ'D ).  
SEE GENERAL NOTE  
"C" AT RIGHT.

40" X 48"  
PALLET.

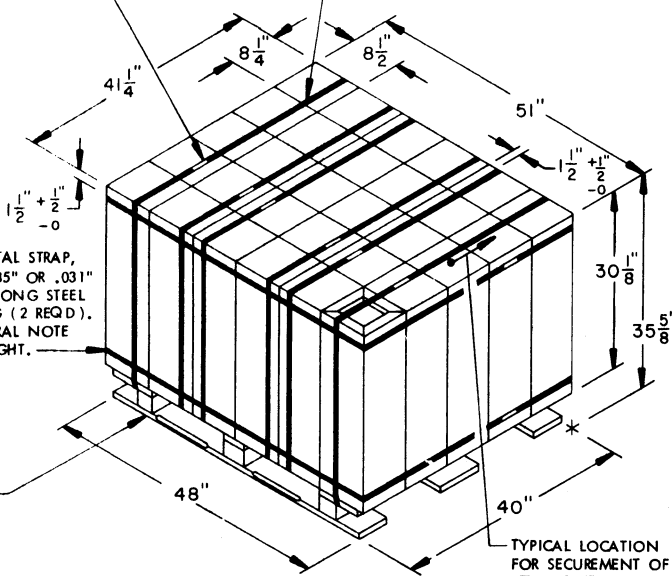

**PALLET UNIT**

SEE GENERAL NOTE "B" AT RIGHT.

30 BOXES OF 81MM CARTRIDGE ( 4 PER WIREBOUND BOX ) @ 51 LBS	---	1,530 LBS ( APPROX )
DUNNAGE	-----	8 LBS
PALLET	-----	80 LBS
<b>TOTAL WEIGHT</b>	-----	<b>1,618 LBS ( APPROX )</b>
<b>CUBE</b>	-----	<b>43.4 CU FT ( APPROX )</b>

**GENERAL NOTES**

- A. THIS APPENDIX CANNOT STAND ALONE BUT MUST BE USED IN CONJUNCTION WITH THE BASIC UNITIZATION PROCEDURES DRAWING 19-48-4116-20PA1002. TO PRODUCE AN APPROVED UNIT LOAD, ALL PERTINENT PROCEDURES, SPECIFICATIONS AND CRITERIA SET FORTH WITHIN THE BASIC DRAWING WILL APPLY TO THE PROCEDURES DELINEATED IN THIS APPENDIX. ANY EXCEPTIONS TO THE BASIC PROCEDURES ARE SPECIFIED IN THIS APPENDIX.
- B. DIMENSIONS, CUBE AND WEIGHT OF A PALLET UNIT WILL VARY SLIGHTLY DEPENDING UPON THE ACTUAL DIMENSIONS OF THE BOXES AND THE WEIGHT OF THE SPECIFIC ITEM BEING UNITIZED.
- C. INSTALL THE HORIZONTAL STRAPS TO ENCIRCLE THE BOXES ON THE PALLET. NOTE THAT THE STRAPS WILL BE LOCATED AS DIMENSIONED, NEAR THE TOP AND BOTTOM OF THE BOXES. HORIZONTAL STRAPS MUST BE TENSIONED AND SEALED PRIOR TO APPLICATION OF TIEDOWN STRAPS.
- D. INSTALL EACH TIEDOWN STRAP TO PASS UNDER THE DECK/STRINGER BOARDS OF THE PALLET. NOTE THAT THE STRAPS WILL BE LOCATED AS DIMENSIONED, NEAR THE SIDE CLEATS OF THE END PANELS OF THE BOX. TIEDOWN STRAPS WILL NOT BE APPLIED UNTIL THE HORIZONTAL STRAPS HAVE BEEN TENSIONED AND SEALED.
- E. THE FOLLOWING DARCOM DRAWINGS ARE APPLICABLE FOR OUTLOADING AND STORAGE OF THE ITEMS COVERED BY THIS APPENDIX.
 

CARLOADING -----	DRAWING 19-48-4115-5PA1002
TRUCKLOADING -----	DRAWING 19-48-4117-11PA1003
STORAGE -----	DRAWING 19-48-4118-1-2-14-22PA1002
- F. FOR METHOD OF SECURING A STRAP CUTTER TO THE PALLET UNIT, SEE DARCOM DRAWING 19-48-4127-20P1000.
- G. IF ITEMS COVERED HEREIN ARE UNITIZED PRIOR TO ISSUANCE OF THIS APPENDIX, THE BOXES NEED NOT BE REUNITIZED SOLELY TO CONFORM TO THIS APPENDIX.
- H. THE UNITIZATION PROCEDURES DEPICTED HEREIN MAY ALSO BE USED FOR UNITIZING 81MM CARTRIDGES WHEN IDENTIFIED BY DIFFERENT NATIONAL STOCK NUMBERS ( NSN ) THAN WHAT IS SHOWN ON THE TITLE PAGE, PROVIDED THE BOX PACK DOES NOT VARY FROM WHAT IS DELINEATED HEREIN. THE EXPLOSIVE CLASSIFICATION OF OTHER ITEMS MAY BE DIFFERENT THAN WHAT IS SHOWN.
- J. IF THERE IS A NEED TO USE FILLER ASSEMBLIES AND AT LEAST TWO PALLET UNITS ARE BEING CONSTRUCTED, NOT MORE THAN 18 FILLERS WILL BE INSTALLED IN ANY ONE PALLET UNIT. ADDITIONAL FILLERS CAN BE PUT IN A SECOND PALLET UNIT AS REQUIRED WHEN THE QUANTITY OF 18 FILLERS IN THE FIRST REDUCED PALLET UNIT IS INSUFFICIENT TO SATISFY THE TOTAL REDUCTION NEEDED. USING TWO PALLET UNITS TO SATISFY THE PALLETIZATION CRITERIA APPLICABLE TO LESS-THAN-FULL PALLET UNITS IS AN EXCEPTION TO THE BASIC PROCEDURES. HOWEVER, THE EXCEPTION IS NECESSARY FOR THE AMMUNITION PACK COVERED BY THIS APPENDIX, TO MOST EFFECTIVELY GET AN ACCEPTABLE, COMPACT AND SOUND PALLET UNIT.

**BILL OF MATERIAL**

PALLET, 40" X 48" -----	1 REQ'D -----	80 LBS
STEEL STRAPPING, 3/4" -----	110.83' REQ'D -----	7.92 LBS
SEAL FOR 3/4" STRAPPING -----	8 REQ'D -----	NIL

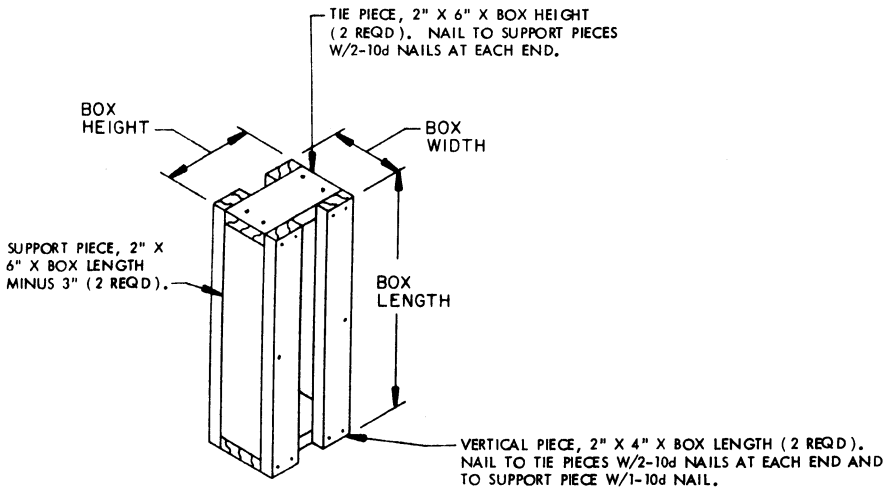

**FILLER ASSEMBLY**

( FOR MINUS ONE BOX )

( SEE GENERAL NOTE "J" ABOVE )