

APPENDIX 43A

UNITIZATION PROCEDURES FOR BOXED AMMUNITION AND COMPONENTS ON 4-WAY ENTRY PALLETS

CARTRIDGE, 81 MM, PACKED 4 PER WOODEN BOX,
UNITIZED 40 BOXES PER 40" X 48" PALLET;
APPROX BOX SIZE 17 $\frac{3}{4}$ " L X 9 $\frac{3}{4}$ " W X 10 $\frac{1}{2}$ " H

PALLET UNIT DATA						
ITEMS INCLUDED		HAZARD CLASSIFICATION				WEIGHT
NSN	DODIC	DOT CLASS	CG CLASS	QD CLASS	COMP GROUP	(LBS)
1315-						
00-028-4968	C225	A	IV	(08)1.2	E	2,088
00-028-4970	C225	A	IV	(08)1.2	E	2,088
00-509-2972	C227	A	IV	(08)1.2	E	2,088
00-555-4778	C225	A	IV	(08)1.2	E	2,088
00-585-1739	C225	A	IV	(08)1.2	E	2,088
00-926-9360	C225	A	IV	(08)1.2	E	2,088
00-935-1992	C227	A	IV	(08)1.2	E	2,088

NOTICE: THIS APPENDIX CANNOT STAND ALONE BUT MUST BE USED IN CONJUNCTION WITH THE BASIC UNITIZATION PROCEDURES DRAWING 19-48-4116-20PA1002.

REVISIONS				DRAFTSMAN <i>PFE/mak</i>	PROJ ENG <i>2/27/79</i>
				CHECKER <i>RSK</i>	LOG ENGR OFFICE <i>RSK</i>
				APPROVED, U. S. ARMY ARMAMENT MATERIEL READINESS COMMAND	
				<i>Sanford Kirby</i> <i>Carol Feller</i> DRRAR - MAD DRRAR - TMO	
				APPROVED BY ORDER OF COMMANDING GENERAL, U. S. ARMY MATERIEL DEVELOPMENT AND READINESS COMMAND (DARCOM) <i>John A. Boyd</i>	
				U. S. ARMY DEFENSE AMMUNITION CENTER AND SCHOOL	
				U. S. ARMY DARCOM DRAWING	
				JULY 1979	
				CLASS	DIVISION
				DRAWING	FILE
				19	48
				4116/43A	20PA 1002

DO NOT SCALE

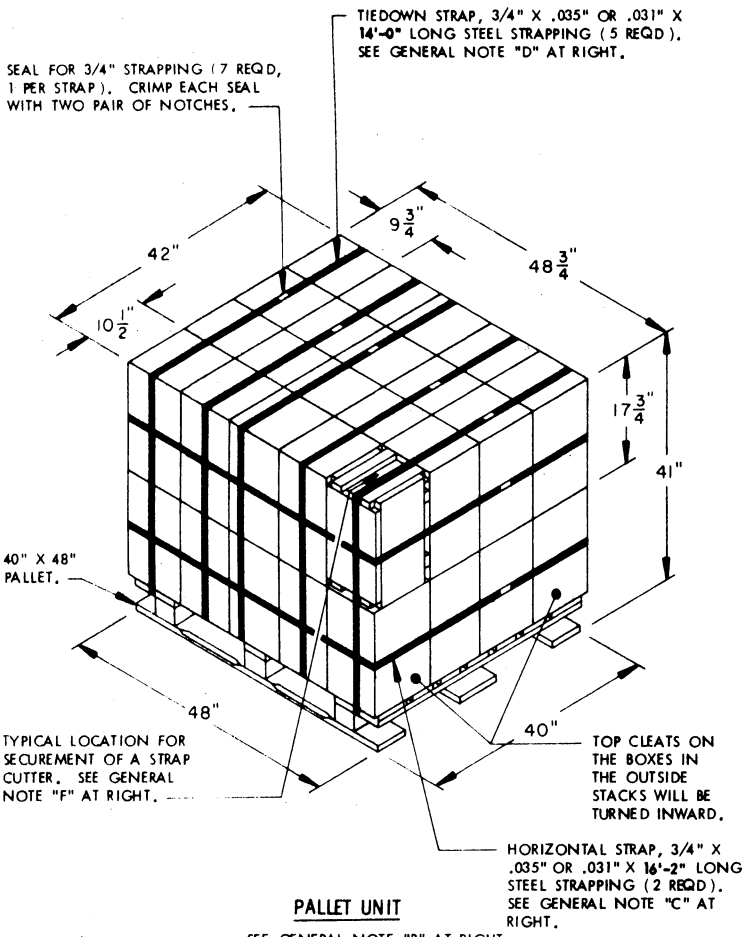

GENERAL NOTES

- A. THIS APPENDIX CANNOT STAND ALONE BUT MUST BE USED IN CONJUNCTION WITH THE BASIC UNITIZATION PROCEDURES DRAWING 19-48-4116-20PA1002. TO PRODUCE AN APPROVED UNIT LOAD, ALL PERTINENT PROCEDURES, SPECIFICATIONS AND CRITERIA SET FORTH WITHIN THE BASIC DRAWING WILL APPLY TO THE PROCEDURES DELINEATED IN THIS APPENDIX, ANY EXCEPTIONS TO THE BASIC PROCEDURES ARE SPECIFIED IN THIS APPENDIX.
- B. DIMENSIONS, CUBE AND WEIGHT OF A PALLET UNIT WILL VARY SLIGHTLY DEPENDING UPON THE ACTUAL DIMENSIONS OF THE BOXES AND THE WEIGHT OF THE SPECIFIC ITEM BEING UNITIZED.
- C. INSTALL EACH HORIZONTAL STRAP TO ENCIRCLE A LAYER OF BOXES ON THE PALLET. HORIZONTAL STRAPS MUST BE TENSIONED AND SEALED PRIOR TO APPLICATION OF TIEDOWN STRAPS.
- D. INSTALL EACH TIEDOWN STRAP TO PASS UNDER THE DECK/STRINGER BOARDS OF THE PALLET AND TO BE LOCATED AS SHOWN. TIEDOWN STRAPS WILL NOT BE APPLIED UNTIL THE HORIZONTAL STRAPS HAVE BEEN TENSIONED AND SEALED.
- E. THE FOLLOWING DARCOM DRAWINGS ARE APPLICABLE FOR UNLOADING AND STORAGE OF THE ITEMS COVERED BY THIS APPENDIX.
 - CARLOADING ----- DRAWING 19-48-4115-5PA1002
 - TRUCKLOADING ----- DRAWING 19-48-4117-11PA1003
 - STORAGE ----- DRAWING 19-48-4118-1-2-14-22PA1002
- F. FOR METHOD OF SECURING A STRAP CUTTER TO THE PALLET UNIT, SEE DARCOM DRAWING 19-48-4127-20P1000.
- G. IF ITEMS COVERED HEREIN ARE UNITIZED PRIOR TO ISSUANCE OF THIS APPENDIX, THE BOXES NEED NOT BE REUNITIZED SOLELY TO CONFORM TO THIS APPENDIX.
- H. THE UNITIZATION PROCEDURES DEPICTED HEREIN MAY ALSO BE USED FOR UNITIZING CARTRIDGE, 81MM WHEN IDENTIFIED BY DIFFERENT NATIONAL STOCK NUMBERS (NSN) THAN WHAT IS SHOWN ON THE TITLE PAGE, PROVIDED THE BOX PACK DOES NOT VARY FROM WHAT IS DELINEATED HEREIN. THE EXPLOSIVE CLASSIFICATION OF OTHER ITEMS MAY BE DIFFERENT THAN WHAT IS SHOWN.

40 BOXES OF CARTRIDGE, 81MM (4 PER BOX) @ 50 LBS	-----	2,000 LBS (APPROX)
DUNNAGE	-----	8 LBS
PALLET	-----	80 LBS
TOTAL WEIGHT	-----	2,088 LBS (APPROX)
CUBE	-----	48.6 CU FT (APPROX)

BILL OF MATERIAL		
PALLET, 40" X 48"	1 REQD	80 LBS
STEEL STRAPPING, 3/4"	102.33 REQD	7.31 LBS
SEAL FOR 3/4" STRAPPING	7 REQD	NIL

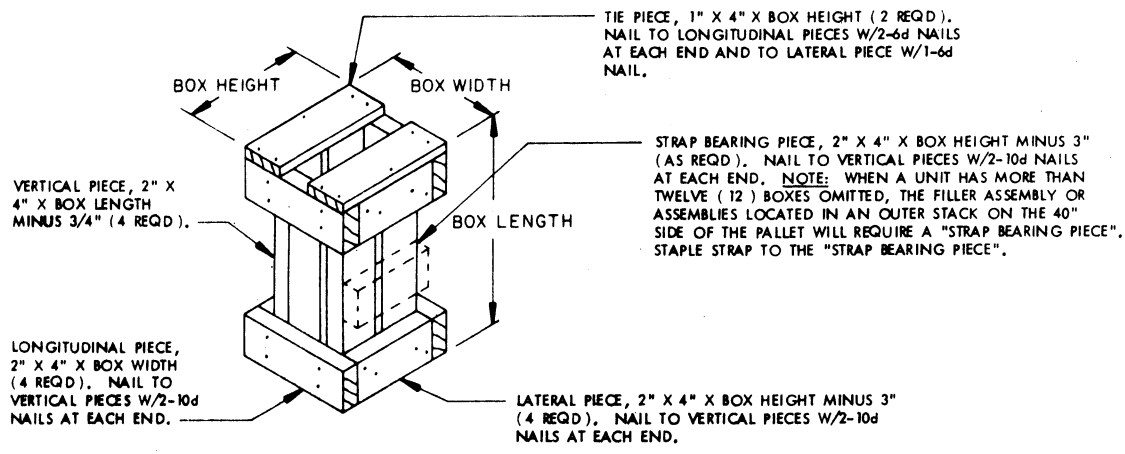

FILLER ASSEMBLY
(FOR MINUS ONE BOX)