

# APPENDIX 43

## UNITIZATION PROCEDURES FOR BOXED AMMUNITION AND COMPONENTS ON 4-WAY ENTRY PALLETS

CARTRIDGE, 81MM, PACKED 3 PER WOODEN BOX,  
UNITIZED 30 BOXES PER 40" X 48" PALLET;  
APPROX BOX SIZE 26-1/8" L X 13-3/4" W  
X 6-5/8" H

NOTICE: THIS APPENDIX CANNOT STAND ALONE BUT MUST BE USED IN CONJUNCTION WITH  
THE BASIC UNITIZATION PROCEDURES DRAWING 19-48-4116-20PA1002.

DISTRIBUTION STATEMENT A.

APPROVED FOR PUBLIC RELEASE;  
DISTRIBUTION IS UNLIMITED.

U.S. ARMY MATERIEL COMMAND DRAWING			
APPROVED, U.S. ARMY ARMAMENT, MUNITIONS AND CHEMICAL COMMAND  <i>David A. ...</i> SMCAR-ESK                      AMSMC-TMG	DRAFTSMAN ENGINEER	D. WHITMORE SANDRA M. SCHULTZ	
APPROVED BY ORDER OF COMMANDING GENERAL, U.S. ARMY MATERIEL COMMAND  <i>William L. ...</i> U.S. ARMY DEFENSE AMMUNITION CENTER AND SCHOOL	SUPPLY ENGINEERING DIVISION	TRANSPORTATION ENGINEERING DIVISION	VALIDATION ENGINEERING DIVISION
	LOGISTICS ENGINEERING OFFICE <i>William F. Ernst</i>		
	JULY 1979		
	CLASS	DIVISION	DRAWING
	REVISION NO. 5	AUGUST 1994	
	19	48	4116/ 43
	SEE THE REVISION LISTING ON PAGE 2		20PA 1002

DO NOT SCALE

PALLET UNIT DATA				
ITEMS INCLUDED		HAZARD CLASS AND DIVISION ●		APPROX WEIGHT LBS
NSN	DODIC	OD CLASS	COMP GROUP	
1315-				
00-028-5004	C222	(08)1.2	E	1,618
00-182-3426	C222	(08)1.2	E	1,618
00-602-5177	C222	(08)1.2	E	1,618
00-702-0724	C222	(08)1.2	E	1,618
00-892-3968	C222	(08)1.2	E	1,618
00-965-0804	C222	(08)1.2	E	1,618
00-542-0179	C223	(08)1.2	E	1,618
00-143-7184	C236	(08)1.2	E	1,618
00-935-6007	C236	(08)1.2	E	1,678
00-935-6013	C236	(08)1.2	E	1,618
00-935-6033	C236	(08)1.2	E	1,618
01-355-0736	C236	(08)1.2	E	1,618
00-134-8984	C256	(08)1.2	E	1,618
00-498-6407	C256	(08)1.2	E	1,618
00-782-5544	C256	(08)1.2	E	1,678
00-782-5547	C256	(08)1.2	E	1,678
00-935-1931	C256	(08)1.2	E	1,618
00-935-6002	C256	(08)1.2	E	1,678
00-935-6010	C256	(08)1.2	E	1,618
00-935-6030	C256	(08)1.2	E	1,618
00-935-6031	C256	(08)1.2	E	1,618
00-935-6032	C256	(08)1.2	E	1,618
01-127-7481	C256	(08)1.2	E	1,618
01-147-6307	C256	(08)1.2	E	1,618

● HAZARD CLASSIFICATION DATA CONTAINED IN THE ABOVE CHART IS FOR GUIDANCE AND INFORMATIONAL PURPOSES ONLY. VERIFICATION OF THE SPECIFIED DATA SHOULD BE MADE BY CONSULTING THE MOST RECENT JOINT HAZARD CLASSIFICATION SYSTEM LISTING OR OTHER APPROVED LISTING(S).

### REVISIONS

REVISION NO. 1, DATED JULY 1982, CONSISTS OF:

1. ADDING ITEM BY NATIONAL STOCK NUMBER TO THE "PALLET UNIT DATA" CHART.

REVISION NO. 2, DATED DECEMBER 1983, CONSISTS OF:

1. ADDING ITEM BY NATIONAL STOCK NUMBER TO "PALLET UNIT DATA" CHART.

REVISION NO. 3, DATED MAY 1984, CONSISTS OF:

1. ADDING ITEMS BY NATIONAL STOCK NUMBER TO "PALLET UNIT DATA" CHART.

REVISION NO. 4, DATED JULY 1989, CONSISTS OF:

1. ADDING ITEM BY NATIONAL STOCK NUMBER TO "PALLET UNIT DATA" CHART.
2. DELETING ITEMS BY NATIONAL STOCK NUMBER FROM "PALLET UNIT DATA" CHART.
3. ADDING GENERAL NOTE "J".

REVISION NO. 5, DATED AUGUST 1994, CONSISTS OF:

1. ADDING ITEMS BY NATIONAL STOCK NUMBER TO "PALLET UNIT DATA" CHART.
2. DELETING ITEM BY NATIONAL STOCK NUMBER FROM "PALLET UNIT DATA" CHART.

**GENERAL NOTES**

- A. THIS APPENDIX CANNOT STAND ALONE BUT MUST BE USED IN CONJUNCTION WITH THE BASIC UNITIZATION PROCEDURES DRAWING 19 48 4116 20PA1002. TO PRODUCE AN APPROVED UNIT LOAD, ALL PERTINENT PROCEDURES, SPECIFICATIONS AND CRITERIA SET FORTH WITHIN THE BASIC DRAWING WILL APPLY TO THE PROCEDURES DELINEATED IN THIS APPENDIX. ANY EXCEPTIONS TO THE BASIC PROCEDURES ARE SPECIFIED IN THIS APPENDIX.
- B. DIMENSIONS, CUBE AND WEIGHT OF A PALLET UNIT WILL VARY SLIGHTLY DEPENDING UPON THE ACTUAL DIMENSIONS OF THE BOXES AND THE WEIGHT OF THE SPECIFIC ITEM BEING UNITIZED.
- C. THE LOAD STRAPS MAY BE THREADED THROUGH THE STRAP SLOTS OF A PALLET OR PRE-POSITIONED ON THE PALLET DECK PRIOR TO PLACING BOXES ON THE PALLET. TIEDOWN STRAPS MUST BE TENSIONED AND SEALED PRIOR TO APPLICATION OF LOAD STRAPS.
- D. INSTALL EACH TIEDOWN STRAP TO PASS UNDER THE DECK/STRINGER BOARDS OF THE PALLET AND TO BE LOCATED AS SHOWN. LOAD STRAPS WILL NOT BE APPLIED UNTIL THE TIEDOWN STRAPS HAVE BEEN TENSIONED AND SEALED.
- E. THE FOLLOWING AMC DRAWINGS ARE APPLICABLE FOR OUTLOADING AND STORAGE OF THE ITEMS COVERED BY THIS APPENDIX.
  - CARLOADING - - - - 19-48-4115-5PA1002
  - TRUCKLOADING - - - - 19 48 4117 11PA1003
  - STORAGE - - - - - 19-48-4118-1-2-3-4-14-22PA1002
  - COMMERCIAL CONTAINER - - - - 19-48-4153-15PA1002
  - MILVAN - - - - - 19-48-4166-15PA1003
  - SIDE OPENING COMMERCIAL CONTAINER - - - - 19-48-6267-15PA1009
- F. FOR METHOD OF SECURING A STRAP CUTTER TO THE PALLET UNIT, SEE AMC DRAWING 19 48 4127 20P1000.
- G. IF ITEMS COVERED HEREIN ARE UNITIZED PRIOR TO ISSUANCE OF THIS APPENDIX, THE BOXES NEED NOT BE REUNITIZED SOLELY TO CONFORM TO THIS APPENDIX.
- H. THE UNITIZATION PROCEDURES DEPICTED HEREIN MAY ALSO BE USED FOR UNITIZING 81MM CARTRIDGES WHEN IDENTIFIED BY DIFFERENT NATIONAL STOCK NUMBERS (NSN) THAN WHAT IS SHOWN ON PAGE 2, PROVIDED THE BOX PACK DOES NOT VARY FROM WHAT IS DELINEATED HEREIN. THE EXPLOSIVE CLASSIFICATION OF OTHER ITEMS MAY BE DIFFERENT THAN WHAT IS SHOWN.
- J. THE STYLE 1 PALLET DELINEATED IN THE DETAIL AT LEFT NEED NOT HAVE CHAMFERS OR STRAP SLOTS AS SPECIFIED WITHIN MILITARY SPECIFICATION MIL-P-15011 WHEN USED FOR THE UNITIZATION OF ITEMS COVERED BY THIS APPENDIX.

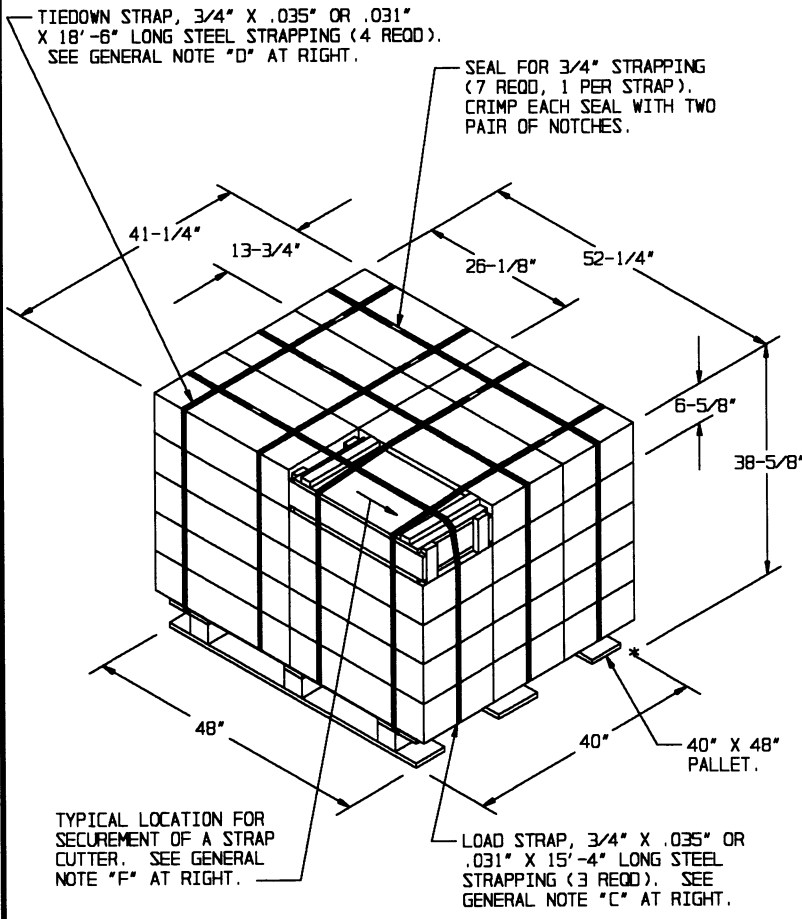

TYPICAL LOCATION FOR SECUREMENT OF A STRAP CUTTER. SEE GENERAL NOTE "F" AT RIGHT.

LOAD STRAP, 3/4" X .035" OR .031" X 15'-4" LONG STEEL STRAPPING (3 REOD). SEE GENERAL NOTE "C" AT RIGHT.

**PALLET UNIT**

SEE GENERAL NOTE "B" AT RIGHT.

30 BOXES OF 81MM CARTRIDGE (3 PER BOX) AT 51 LBS	- - - - -	1,530 LBS (APPROX)
DUNNAGE	- - - - -	8 LBS
PALLET	- - - - -	80 LBS
<b>TOTAL WEIGHT</b>		<b>1,618 LBS (APPROX)</b>
<b>CUBE</b>		<b>48.2 CU FT (APPROX)</b>

BILL OF MATERIAL			
PALLET, 40" X 48"	- - - - -	1 REOD	- - - - 80 LBS
STEEL STRAPPING, 3/4"	- - - - -	100.00' REOD	- - - 7.14 LBS
SEAL FOR 3/4" STRAPPING	- - - - -	7 REOD	- - - - NIL

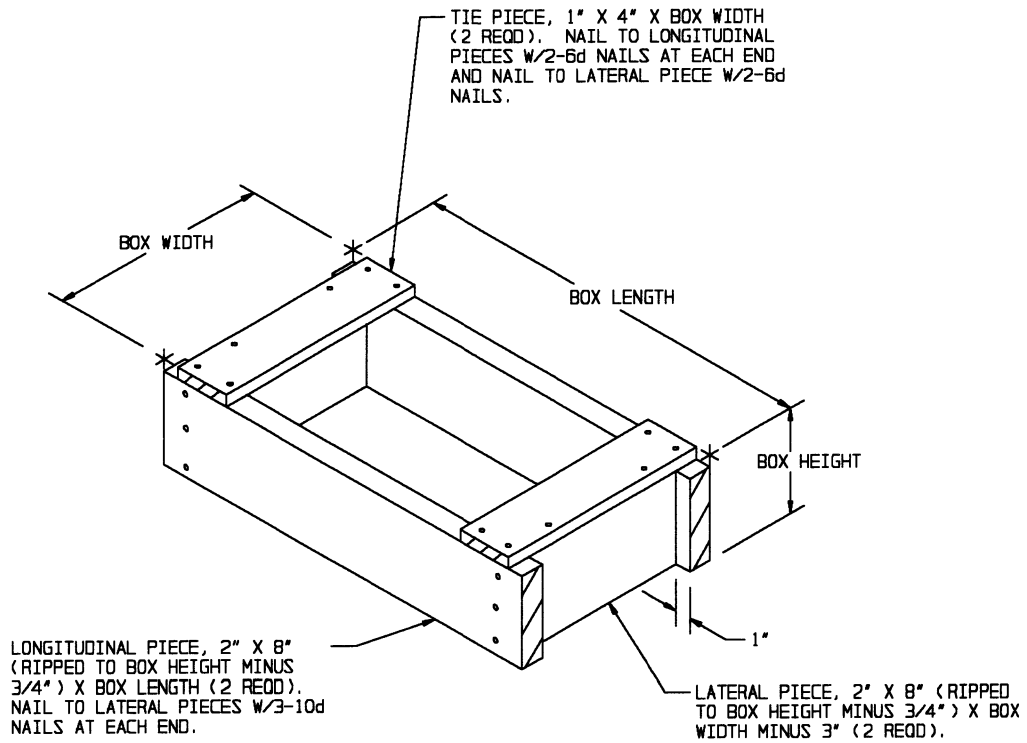

**FILLER ASSEMBLY**  
 (FOR MINUS ONE BOX)