

APPENDIX 4I

UNITIZATION PROCEDURES FOR BOXED AMMUNITION AND COMPONENTS ON 4-WAY ENTRY PALLETS

CARTRIDGE, 76MM, BLANK, PACKED 8 PER
WOODEN BOX, UNITIZED 30 BOXES PER 40" X 48"
PALLET; APPROX BOX SIZE 22 $\frac{1}{4}$ " L X 11 $\frac{1}{8}$ " W X 10" H

PALLET UNIT DATA						
ITEMS INCLUDED		HAZARD CLASSIFICATION				WEIGHT
NSN	DODIC	DOT CLASS	CG CLASS	QD CLASS	COMP GROUP	(LBS)
1315-00- 293-8287 203-4235	C131	B	II-B	4	E	2,068
	C131	B	II-B	4	E	2,068

NOTICE: THIS APPENDIX CANNOT STAND ALONE BUT MUST BE
USED IN CONJUNCTION WITH THE BASIC UNITIZATION
PROCEDURES DRAWING 19-48-4116-20PA1002.

REVISIONS				DRAFTSMAN <i>Sm H/mk</i>	PROJ ENG <i>807/lew</i>
				CHECKER <i>SGE</i>	LOG ENGRG OFFICE <i>John/Syd</i>
APPROVED, U. S. ARMY ARMAMENT MATERIEL READINESS COMMAND					
			<i>J.A. Jackson</i>	<i>Donald P. Feltz</i>	
			DRSAR - MAD	DRSAR - TMA	
APPROVED BY ORDER OF COMMANDING GENERAL, U. S. ARMY MATERIEL DEVELOPMENT AND READINESS COMMAND (DARCOM)					
			<i>W. Ehringer</i>		
DARCOM AMMO CENTER					
U. S. ARMY DARCOM DRAWING					
OCTOBER 1977					
CLASS	DIVISION	DRAWING	FILE		
19	48	4116/41	20PA 1002		

DO NOT SCALE

GENERAL NOTES

- A. THIS APPENDIX CANNOT STAND ALONE BUT MUST BE USED IN CONJUNCTION WITH THE BASIC UNITIZATION PROCEDURES DRAWING 19-48-4116-20PA1002. TO PRODUCE AN APPROVED UNIT LOAD, ALL PERTINENT PROCEDURES, SPECIFICATIONS AND CRITERIA SET FORTH WITHIN THE BASIC DRAWING WILL APPLY TO THE PROCEDURES DELINEATED IN THIS APPENDIX. ANY EXCEPTIONS TO THE BASIC PROCEDURES ARE SPECIFIED IN THIS APPENDIX.
- B. DIMENSIONS, CUBE AND WEIGHT OF A PALLET UNIT WILL VARY SLIGHTLY DEPENDING UPON THE ACTUAL DIMENSIONS OF THE BOXES AND THE WEIGHT OF THE SPECIFIC ITEM BEING UNITIZED.
- C. THE LOAD STRAPS MAY BE THREADED THROUGH THE STRAP SLOT OF A PALLET OR PRE-POSITIONED ON THE PALLET DECK PRIOR TO PLACING BOXES ON THE PALLET. LOAD STRAPS MUST BE TENSIONED AND SEALED PRIOR TO APPLICATION OF TIEDOWN STRAPS.
- D. INSTALL EACH TIEDOWN STRAP TO PASS UNDER THE DECK/STRINGER BOARDS OF THE PALLET AND TO BE LOCATED AS SHOWN. TIEDOWN STRAPS WILL NOT BE APPLIED UNTIL THE LOAD STRAPS HAVE BEEN TENSIONED AND SEALED.
- E. THE FOLLOWING DARCOM DRAWINGS ARE APPLICABLE FOR OUTLOADING AND STORAGE OF THE ITEMS COVERED BY THIS APPENDIX.
 - CARLOADING ----- DRAWING 19-48-4115-5PA1002
 - TRUCKLOADING ----- DRAWING 19-48-4117-11PA1003
 - STORAGE ----- DRAWING 19-48-4118-1-2-14-22PA1002
- F. FOR METHOD OF SECURING A STRAP CUTTER TO THE PALLET UNIT, SEE DARCOM DRAWING 19-48-4127-20P1000.
- G. IF ITEMS COVERED HEREIN ARE UNITIZED PRIOR TO ISSUANCE OF THIS APPENDIX, THE BOXES NEED NOT BE REUNITIZED SOLELY TO CONFORM TO THIS APPENDIX.
- H. THE UNITIZATION PROCEDURES DEPICTED HEREIN MAY ALSO BE USED FOR UNITIZING 76 MM CARTRIDGES WHEN IDENTIFIED BY DIFFERENT NATIONAL STOCK NUMBERS (NSN) THAN WHAT IS SHOWN ON THE TITLE PAGE, PROVIDED THE BOX PACK DOES NOT VARY FROM WHAT IS DELINEATED HEREIN. THE EXPLOSIVE CLASSIFICATION OF OTHER ITEMS MAY BE DIFFERENT THAN WHAT IS SHOWN.

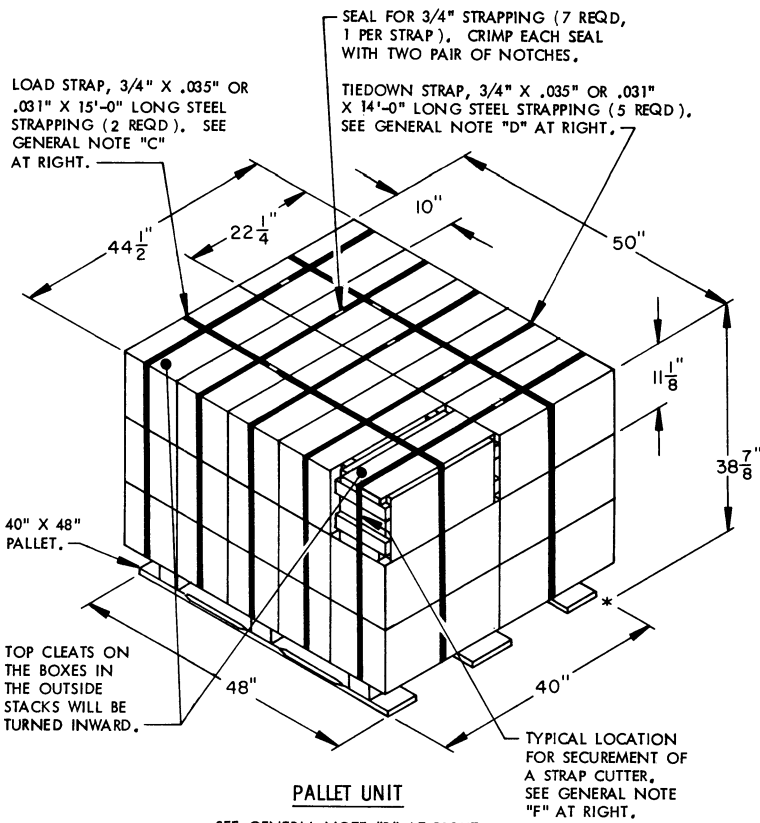

PALLET UNIT

SEE GENERAL NOTE "B" AT RIGHT.

30 BOXES OF 76 MM CARTRIDGE (8 PER BOX) @ 66 LBS	---	1,980 LBS (APPROX)
DUNNAGE	-----	8 LBS
PALLET	-----	80 LBS
TOTAL WEIGHT	-----	2,068 LBS (APPROX)
CUBE	-----	50 CU FT (APPROX)

BILL OF MATERIAL

PALLET, 40" X 48"	1 REQD	80 LBS
STEEL STRAPPING, 3/4"	100' REQD	8 LBS
SEAL FOR 3/4" STRAPPING	7 REQD	NIL

TIE PIECE, 1" X 4" X BOX HEIGHT (2 REQD).. NAIL TO LONGITUDINAL PIECES W/1-6d NAIL AT EACH END AND TO LATERAL PIECES W/3-6d NAILS.

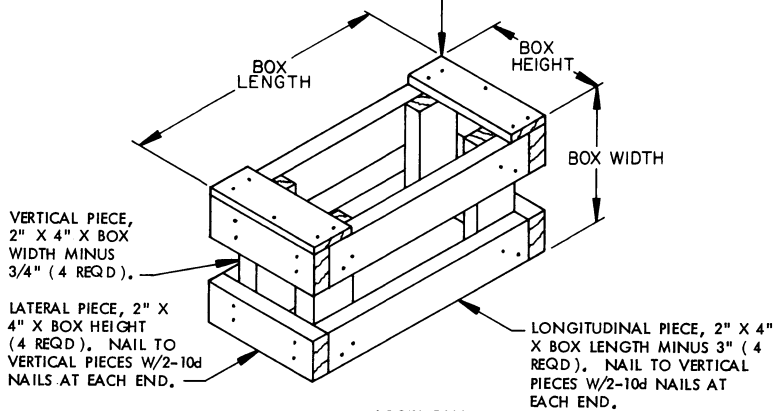

FILLER ASSEMBLY

(FOR MINUS ONE BOX)