

# APPENDIX 40

## UNITIZATION PROCEDURES FOR BOXED AMMUNITION AND COMPONENTS ON 4-WAY ENTRY PALLETS

CARTRIDGE, 75MM, BLANK, PACKED 15 PER WOODEN  
BOX, UNITIZED 32 BOXES PER 42" X 53" PALLET;  
APPROX BOX SIZE 22-13/16" L X 13-7/16" W X  
10-1/2" H

NOTICE: THIS APPENDIX CANNOT STAND ALONE BUT MUST BE USED IN CONJUNCTION WITH  
THE BASIC UNITIZATION PROCEDURES DRAWING 19-48-4116-20PA1002.

DISTRIBUTION STATEMENT A.

APPROVED FOR PUBLIC RELEASE;  
DISTRIBUTION IS UNLIMITED.

| U. S. ARMY MATERIEL COMMAND DRAWING   |  |  |   |
|---|--|--|---|
| APPROVED, U.S. ARMY ARMAMENT, MUNITIONS AND<br>CHEMICAL COMMAND<br><br><i>David A. Perkowski</i><br>SMCAR-ESK   | DRAFTSMAN<br>ENGINEER<br>D. WHITMORE<br>SANDRA M. SCHULTZ                | SUPPLY ENGINEERING<br>DIVISION<br><i>S. Schultz</i>      | TRANSPORTATION<br>ENGINEERING<br>DIVISION<br><i>W. Franck</i> |
| APPROVED BY ORDER OF COMMANDING GENERAL, U.S.<br>ARMY MATERIEL COMMAND<br><br><i>John L. Boyard</i><br>U.S. ARMY DEFENSE AMMUNITION CENTER AND SCHOOL | AMSMC-TMT<br><br>LOGISTICS ENGINEERING OFFICE<br><i>William F. Ernst</i> | VALIDATION<br>ENGINEERING<br>DIVISION<br><i>K.M. ...</i> | NOVEMBER 1983   |
| REVISION NO. 3      AUGUST 1994<br><br>SEE THE REVISION LISTING ON PAGE 2   | CLASS<br>19  | DIVISION<br>48   | DRAWING<br>4116/<br>40<br><br>FILE<br>20PA<br>1002            |

DO NOT SCALE

| PALLET UNIT DATA |      |                             |            |                   |
|------------------|------|-----------------------------|------------|-------------------|
| ITEMS INCLUDED   |      | HAZARD CLASS AND DIVISION ● |            | APPROX WEIGHT LBS |
| NSN              | DDIC | OD CLASS                    | COMP GROUP |                   |
| 1315-00-096-3087 | C025 | 1.3                         | C          | 2,625             |
| 00-096-3088      | C025 | 1.3                         | C          | 2,625             |
| 00-892-4951      | C025 | 1.3                         | C          | 2,625             |
| 01-307-3944      | C025 | 1.3                         | C          | 2,177             |

● HAZARD CLASSIFICATION DATA CONTAINED IN THE ABOVE CHART IS FOR GUIDANCE AND INFORMATIONAL PURPOSES ONLY. VERIFICATION OF THE SPECIFIED DATA SHOULD BE MADE BY CONSULTING THE MOST RECENT JOINT HAZARD CLASSIFICATION SYSTEM LISTING OR OTHER APPROVED LISTING(S).

### REVISIONS

REVISION NO. 1, DATED MARCH 1984, CONSISTS OF:

1. PLACING BOXES ON A 42" X 53" PALLET.
2. UPDATING DRAWING TO CONFORM TO 1 ABOVE.

REVISION NO. 2, DATED JULY 1992, CONSISTS OF:

1. ADDING ITEM BY NATIONAL STOCK NUMBER TO THE "PALLET UNIT DATA" CHART.

REVISION NO. 3, DATED AUGUST 1994, CONSISTS OF:

1. CHANGING WEIGHT OF NSN ON "PALLET UNIT DATA" CHART.
2. ADDING ITEMS BY NATIONAL STOCK NUMBER TO THE "PALLET UNIT DATA" CHART.

**GENERAL NOTES**

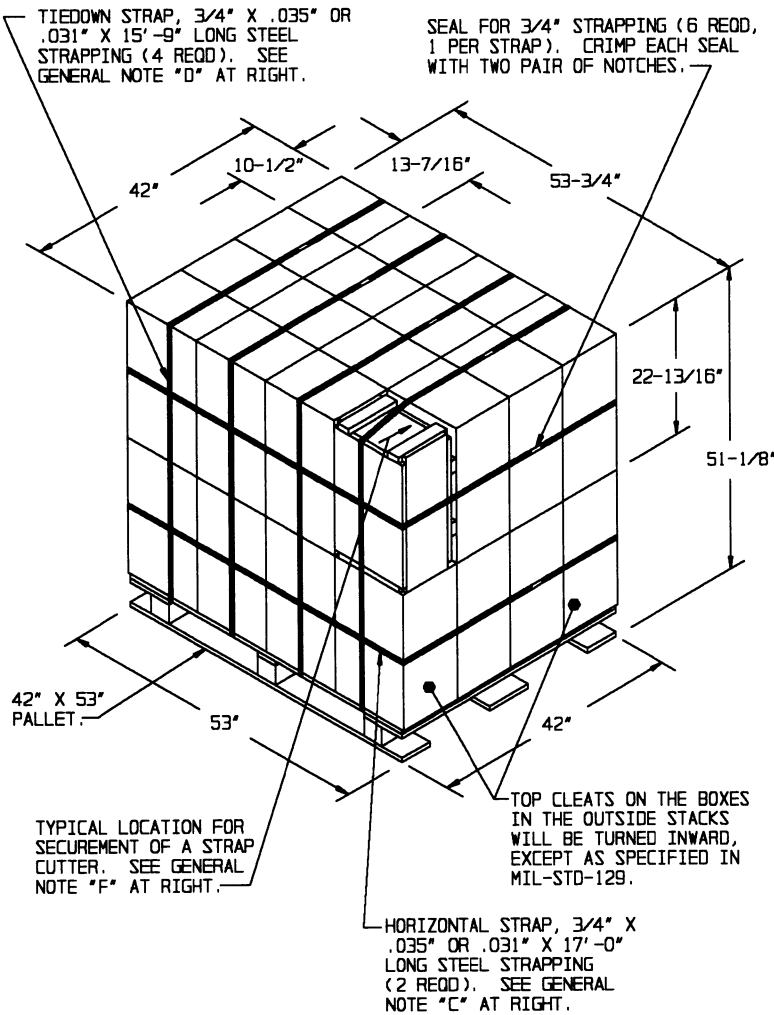

- A. THIS APPENDIX CANNOT STAND ALONE BUT MUST BE USED IN CONJUNCTION WITH THE BASIC UNITIZATION PROCEDURES DRAWING 19-48-4116-20PA1002. TO PRODUCE AN APPROVED UNIT LOAD, ALL PERTINENT PROCEDURES, SPECIFICATIONS AND CRITERIA SET FORTH WITHIN THE BASIC DRAWING WILL APPLY TO THE PROCEDURES DELINEATED IN THIS APPENDIX. ANY EXCEPTIONS TO THE BASIC PROCEDURES ARE SPECIFIED IN THIS APPENDIX.
- B. DIMENSIONS, CUBE AND WEIGHT OF A PALLET UNIT WILL VARY SLIGHTLY DEPENDING UPON THE ACTUAL DIMENSIONS OF THE BOXES AND THE WEIGHT OF THE SPECIFIC ITEM BEING UNITIZED.
- C. INSTALL EACH HORIZONTAL STRAP TO ENCIRCLE A LAYER OF BOXES ON THE PALLET. HORIZONTAL STRAPS MUST BE TENSIONED AND SEALED PRIOR TO THE APPLICATION OF TIEDOWN STRAPS.
- D. INSTALL EACH TIEDOWN STRAP TO PASS UNDER THE TOP DECK BOARDS OF THE PALLET AND TO BE LOCATED AS SHOWN. TIEDOWN STRAPS WILL NOT BE APPLIED UNTIL THE HORIZONTAL STRAPS HAVE BEEN TENSIONED AND SEALED.
- E. THE FOLLOWING AMC DRAWINGS ARE APPLICABLE FOR OUTLOADING AND STORAGE OF THE ITEMS COVERED BY THIS APPENDIX.

|                                      |                                |
|--------------------------------------|--------------------------------|
| CARLOADING - - - -                   | 19-48-4115-5PA1002             |
| TRUCKLOADING - - - -                 | 19-48-4117-11PA1003            |
| STORAGE - - - - -                    | 19-48-4118-1-2-3-4-14-22PA1002 |
| END OPENING ISO CONTAINER - - - - -  | 19-48-4153-15PA1002            |
| MILVAN - - - - -                     | 19-48-4166-15PA1003            |
| SIDE OPENING ISO CONTAINER - - - - - | 19-48-4267-15PA1009            |

- F. FOR METHOD OF SECURING A STRAP CUTTER TO THE PALLET UNIT, SEE AMC DRAWING 19-48-4127-20P1000.
- G. IF ITEMS COVERED HEREIN ARE UNITIZED PRIOR TO ISSUANCE OF THIS APPENDIX, THE BOXES NEED NOT BE REUNITIZED SOLELY TO CONFORM TO THIS APPENDIX.
- H. THE UNITIZATION PROCEDURES DEPICTED HEREIN MAY ALSO BE USED FOR UNITIZING 75MM CARTRIDGES WHEN IDENTIFIED BY DIFFERENT NATIONAL STOCK NUMBERS (NSN) THAN WHAT IS SHOWN ON PAGE 2, PROVIDED THE BOX PACK DOES NOT VARY FROM WHAT IS DELINEATED HEREIN. THE EXPLOSIVE CLASSIFICATION OF OTHER ITEMS MAY BE DIFFERENT THAN WHAT IS SHOWN.
- J. WHEN THE UNIT LOAD DEPICTED AT LEFT IS TO BE USED FOR UNITIZING MARINE CORP AMMUNITION, ONE LAYER OF BOXES MUST BE OMITTED, THE HORIZONTAL STRAP CORRESPONDING TO THE DELETED LAYER MUST BE OMITTED, AND TIEDOWN STRAP LENGTH MUST BE DECREASED TO 11'-11". THIS WILL RESULT IN AN OVERALL UNIT HEIGHT OF 28-1/4", A GROSS UNIT WEIGHT OF 1,279 POUNDS, AND A UNIT CUBE OF 37.0 CUBIC FEET.
- K. THE STYLE 18 PALLET DELINEATED IN THE DETAIL AT LEFT NEED NOT HAVE CHAMFERS OR STRAP SLOTS AS SPECIFIED WITHIN MILITARY SPECIFICATION MIL-P-15011 WHEN USED FOR THE UNITIZATION OF ITEMS COVERED BY THIS APPENDIX.

**PALLET UNIT**

SEE GENERAL NOTE "B" AT RIGHT.

|   |                     |
|---|---------------------|
| 32 BOXES OF 75MM CARTRIDGE (15 PER BOX) AT 79 LBS - | 2,528 LBS (APPROX)  |
| DUNNAGE - - - - -                                   | 7 LBS               |
| PALLET - - - - -                                    | 90 LBS              |
| <hr/>   |                     |
| TOTAL WEIGHT - - - - -                              | 2,625 LBS (APPROX)  |
| CUBE - - - - -                                      | 66.8 CU FT (APPROX) |

**BILL OF MATERIAL**

|                         |           |        |           |          |
|-------------------------|-----------|--------|-----------|----------|
| PALLET, 42" X 53"       | - - - - - | 1 REQD | - - - - - | 90 LBS   |
| STEEL STRAPPING, 3/4"   | - 97.00'  | REQD   | - - - - - | 6.93 LBS |
| SEAL FOR 3/4" STRAPPING | - - - - - | 6 REQD | - - - - - | NIL      |

TIE PIECE, 1" X 4" X BOX HEIGHT  
(2 REQD). NAIL TO LONGITUDINAL  
PIECES W/2-6d NAILS AT EACH END  
AND TO LATERAL PIECE W/1-6d NAIL.

BOX HEIGHT      BOX WIDTH

LONGITUDINAL PIECE, 2" X 4"  
X BOX WIDTH (4 REQD). NAIL  
TO VERTICAL PIECES W/2-10d  
NAILS AT EACH END.

VERTICAL PIECE, 2" X 4"  
X BOX LENGTH MINUS 3/4"  
(4 REQD).

BOX LENGTH

VERTICAL SUPPORT PIECE, 2" X 4" BY  
CUT-TO-FIT (2 REQD). NAIL TO VERTICAL  
PIECE W/3-10d NAILS. NOTE: WHEN A UNIT  
HAS MORE THAN EIGHT (8) BOXES OMITTED,  
THE FILLER ASSEMBLY OR ASSEMBLIES IN AN  
OUTER STACK ON THE 53" SIDE OR SIDES OF  
THE PALLET WILL REQUIRE VERTICAL SUPPORT  
PIECES AS SHOWN.

STRAP BEARING PIECE, 2" X 4" X BOX HEIGHT MINUS 3"  
(AS REQD). NAIL TO VERTICAL PIECES W/2-10d NAILS AT  
EACH END. NOTE: WHEN A UNIT HAS MORE THAN EIGHT (8)  
BOXES OMITTED, THE FILLER ASSEMBLY OR ASSEMBLIES  
LOCATED IN AN OUTER STACK ON THE 42" SIDE OR SIDES  
OF THE PALLET WILL REQUIRE A "STRAP BEARING PIECE"  
POSITIONED UNDER THE HORIZONTAL STRAP. STAPLE STRAP  
TO STRAP BEARING PIECE.

LATERAL PIECE, 2" X 4" X BOX  
HEIGHT MINUS 3" (4 REQD). NAIL  
TO VERTICAL PIECES W/2-10d  
NAILS AT EACH END.

**FILLER ASSEMBLY**

(FOR MINUS ONE BOX)