

APPENDIX 37A

UNITIZATION PROCEDURES FOR BOXED AMMUNITION AND COMPONENTS ON 4-WAY ENTRY PALLETS

CARTRIDGE, 9MM, PRACTICE, M934 (AT4), PACKED
3,000 PER PLYWOOD BOX, UNITIZED 28 BOXES PER
35" X 45 $\frac{1}{2}$ " PALLET; APPROX BOX SIZE 14 $\frac{7}{8}$ " L X
9 $\frac{1}{8}$ " W X 6 $\frac{3}{4}$ " H

PALLET UNIT DATA						
ITEMS INCLUDED		HAZARD CLASSIFICATION ^①				WEIGHT
NSN	DODIC	DOT CLASS	CG CLASS	QD CLASS	COMP GROUP	(LBS)
1305-01-214-8684	A358	C	I	1.4	S	3,151

THIS DRAWING SUPERSEDES DRAWING 19-48-5265-GM20AT2 DATED JUNE 1986.

NOTICE: THIS APPENDIX CANNOT STAND ALONE BUT MUST BE USED IN CONJUNCTION WITH THE BASIC UNITIZATION PROCEDURES DRAWING 19-48-4116-20PA1002.

^① HAZARD CLASSIFICATION DATA CONTAINED IN THE ABOVE CHART IS FOR GUIDANCE AND INFORMATIONAL PURPOSES ONLY. VERIFICATION OF THE SPECIFIED DATA SHOULD BE MADE BY CONSULTING THE MOST RECENT JOINT HAZARD CLASSIFICATION SYSTEM LISTING OR OTHER APPROVED LISTING(S).

REVISIONS				DRAFTSMAN / SM	PROJ ENG
				SV / SM	LAF/WRF
				CHECKER	LOG ENGRG OFFICE
				GKG	W.F. Ernst
APPROVED, U.S. ARMY ARMAMENT, MUNITIONS AND CHEMICAL COMMAND					
				<i>Donald P. Kovich</i>	<i>S. D. Byrd</i>
				SICAR - ESK	AMSIC - TMD
APPROVED BY ORDER OF COMMANDING GENERAL, U.S. ARMY MATERIEL COMMAND (AMC)					
				<i>William F. Ernst</i>	
U.S. ARMY AMC DRAWING					
AUGUST 1988					
CLASS	DIVISION	DRAWING	FILE		
19	48	4116/ 37A	20PA 1002		

DO NOT SCALE

GENERAL NOTES

- A. THIS APPENDIX CANNOT STAND ALONE BUT MUST BE USED IN CONJUNCTION WITH THE BASIC UNITIZATION PROCEDURES DRAWING 19-48-4116-20PA1002. TO PRODUCE AN APPROVED UNIT LOAD, ALL PERTINENT PROCEDURES, SPECIFICATIONS AND CRITERIA SET FORTH WITHIN THE BASIC DRAWING WILL APPLY TO THE PROCEDURES DELINEATED IN THIS APPENDIX. ANY EXCEPTIONS TO THE BASIC PROCEDURES ARE SPECIFIED IN THIS APPENDIX.
- B. DIMENSIONS, CUBE AND WEIGHT OF A PALLET UNIT WILL VARY SLIGHTLY DEPENDING UPON THE ACTUAL DIMENSIONS OF THE BOXES AND THE WEIGHT OF THE SPECIFIC ITEM BEING UNITIZED.
- C. INSTALL THE HORIZONTAL STRAP TO ENCIRCLE THE LAYER OF BOXES. THE HORIZONTAL STRAP MUST BE TENSIONED AND SEALED PRIOR TO THE APPLICATION OF TIEDOWN STRAPS.
- D. INSTALL EACH TIEDOWN STRAP TO PASS UNDER THE DECK/STRINGER BOARDS OF THE PALLET AND TO BE LOCATED AS SHOWN. TIEDOWN STRAPS WILL NOT BE APPLIED UNTIL THE HORIZONTAL STRAP HAS BEEN TENSIONED AND SEALED.
- E. THE FOLLOWING AMC (DARCOM) DRAWINGS ARE APPLICABLE FOR OUT-LOADING AND STORAGE OF THE ITEMS COVERED BY THIS APPENDIX.
 CARLOADING ----- DRAWING 19-48-4115-3PA1002.
 TRUCKLOADING ----- DRAWING 19-48-4117-11PA1003 OR
 DRAWING 19-48-4237-11PA1007.
 STORAGE ----- DRAWING 19-48-4118-1-2-3-4-14-22PA1002.
- F. FOR METHOD OF SECURING A STRAP CUTTER TO THE PALLET UNIT, SEE DARCOM DRAWING 19-48-4127-20P1000.
- G. IF ITEMS COVERED HEREIN ARE UNITIZED PRIOR TO ISSUANCE OF THIS APPENDIX, THE BOXES NEED NOT BE REUNITIZED SOLELY TO CONFORM TO THIS APPENDIX.
- H. THE UNITIZATION PROCEDURES DEPICTED HEREIN MAY ALSO BE USED FOR UNITIZING 9MM CARTRIDGES WHEN IDENTIFIED BY DIFFERENT NATIONAL STOCK NUMBERS (NSN) THAN WHAT IS SHOWN ON THE TITLE PAGE, PROVIDED THE BOX PACK DOES NOT VARY FROM WHAT IS DELINEATED HEREIN. THE EXPLOSIVE CLASSIFICATION OF OTHER ITEMS MAY BE DIFFERENT THAN WHAT IS SHOWN.
- J. THE STYLE 1A PALLET DELINEATED IN THE DETAIL AT LEFT NEED NOT HAVE CHAMFERS OR STRAP SLOTS AS SPECIFIED WITHIN MILITARY SPECIFICATION MIL-P-15011 WHEN USED FOR THE UNITIZATION OF THE ITEMS COVERED BY THIS APPENDIX.

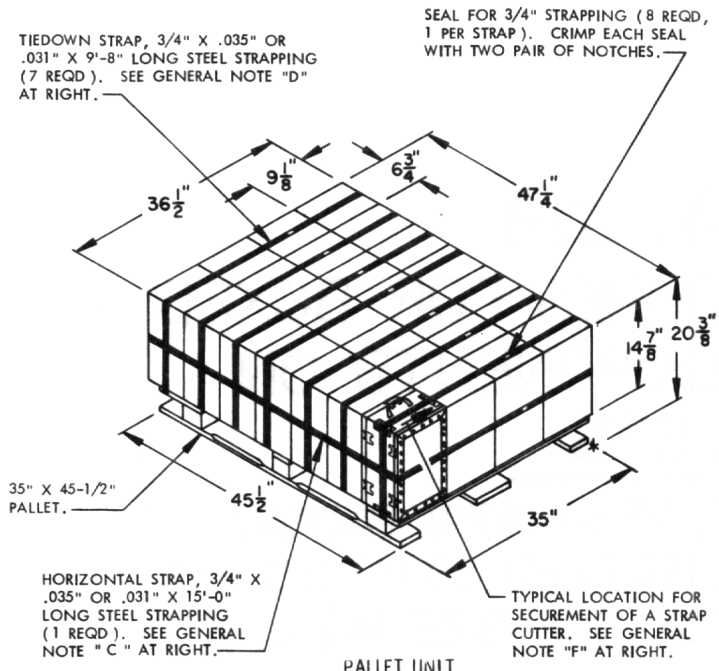

PALLET UNIT

SEE GENERAL NOTE "B" AT RIGHT.

28 BOXES OF 9MM CARTRIDGES (3,000 PER BOX) @ 110 LBS	-----	3,080 LBS (APPROX)
DUNNAGE	-----	6 LBS
PALLET	-----	65 LBS

TOTAL WEIGHT	-----	3,151 LBS (APPROX)
CUBE	-----	20.3 CU FT (APPROX)

BILL OF MATERIAL				
PALLET, 35" X 45-1/2"	-----	1 REQD	-----	65 LBS
STEEL STRAPPING, 3/4"	-----	82.67' REQD	-----	5.90 LBS
SEAL FOR 3/4" STRAPPING	-----	8 REQD	-----	NIL

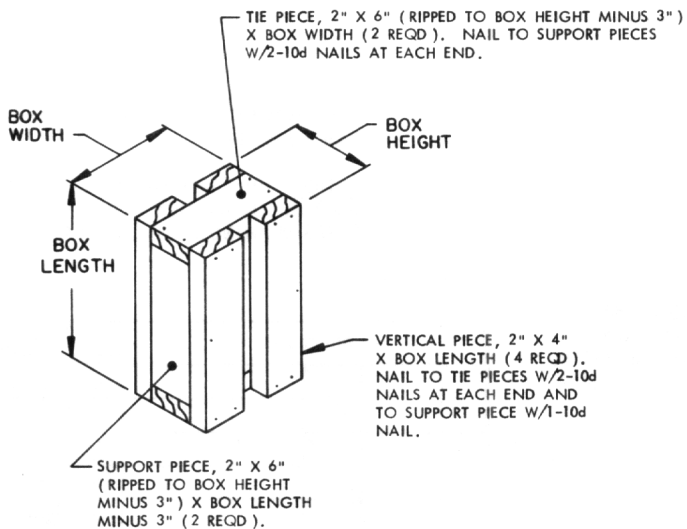

FILLER ASSEMBLY
(FOR MINUS ONE BOX)