

APPENDIX 30

UNITIZATION PROCEDURES FOR BOXED AMMUNITION AND COMPONENTS ON 4-WAY ENTRY PALLETS

FIN, MORTAR CARTRIDGE, M5, FOR 60MM PROJECTILE,
TRAINING, M69, PACKED 200 PER WOODEN BOX,
UNITIZED 12 BOXES PER 40" X 48" PALLET; APPROX
BOX SIZE 27 $\frac{3}{4}$ " L X 14" W X 13 $\frac{1}{2}$ " H

PALLET UNIT DATA						
ITEMS INCLUDED		HAZARD CLASSIFICATION				WEIGHT
NSN	DODIC	DOT CLASS	CG CLASS	OD CLASS	COMP GROUP	(LBS)
1310-00-301-1095	B624	C	I	1	B	1,321

NOTICE: THIS APPENDIX CANNOT STAND ALONE BUT MUST
BE USED IN CONJUNCTION WITH THE BASIC UNITIZATION
PROCEDURES DRAWING 19-48-4116-20PA1002.

REVISIONS				DRAFTSMAN <i>RWH</i>	PROJ ENG <i>AWD</i>
				CHECKER <i>WBA</i>	LOG ENGINE OFFICE <i>WBA</i>
APPROVED, U. S. ARMY ARMAMENT MATERIEL READINESS COMMAND					
				<i>Robert Smith</i> <i>Donald C. Feltner</i> <small>OWNER - M&O</small> <small>DESAR - TMA</small>	
APPROVED BY ORDER OF COMMANDING GENERAL, U. S. ARMY MATERIEL DEVELOPMENT AND READINESS COMMAND (DARCOM)					
<i>W. S. Ehrig</i> DARCOM AMMO CENTER					
U. S. ARMY DARCOM DRAWING					
APRIL 1977					
CLASS	DIVISION	DRAWING	FILE		
19	48	4116/30	20PA 1002		

DO NOT SCALE

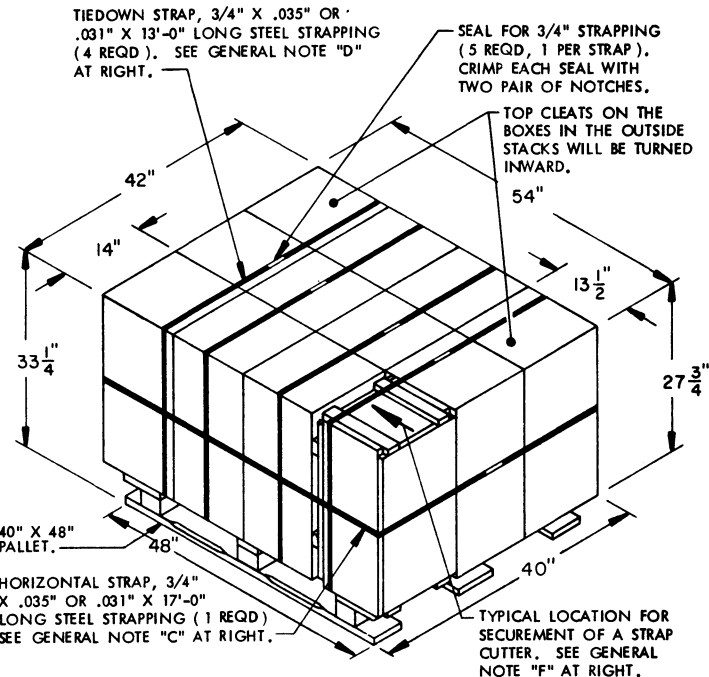

PALLET UNIT

SEE GENERAL NOTE "B" AT RIGHT.

12 BOXES OF FIN ASSEMBLY (60MM) (200 PER BOX) @ 103 LBS	----	1,236 LBS (APPROX)
DUNNAGE	-----	5 LBS
PALLET	-----	80 LBS
TOTAL WEIGHT	-----	1,321 LBS (APPROX)
CUBE	-----	36.4 CU FT

BILL OF MATERIAL				
PALLET, 40" X 48"	-----	1 REQD	-----	80 LBS
STEEL STRAPPING, 3/4"	-----	69' REQD	-----	5 LBS
SEAL FOR 3/4" STRAPPING	-----	5 REQD	-----	NIL

GENERAL NOTES

- A. THIS APPENDIX CANNOT STAND ALONE BUT MUST BE USED IN CONJUNCTION WITH THE BASIC UNITIZATION PROCEDURES DRAWING 19-48-4116-20PA1002. TO PRODUCE AN APPROVED UNIT LOAD, ALL PERTINENT PROCEDURES, SPECIFICATIONS AND CRITERIA SET FORTH WITHIN THE BASIC DRAWING WILL APPLY TO THE PROCEDURES DELINEATED IN THIS APPENDIX. ANY EXCEPTIONS TO THE BASIC PROCEDURES ARE SPECIFIED IN THIS APPENDIX.
- B. DIMENSIONS, CUBE AND WEIGHT OF A PALLET UNIT WILL VARY SLIGHTLY DEPENDING UPON THE ACTUAL DIMENSIONS OF THE BOXES AND THE WEIGHT OF THE SPECIFIC ITEM BEING UNITIZED.
- C. INSTALL EACH HORIZONTAL STRAP TO ENCIRCLE EACH LAYER OF BOXES ON THE PALLET. HORIZONTAL STRAP MUST BE TENSIONED AND SEALED PRIOR TO APPLICATION OF TIEDOWN STRAPS.
- D. INSTALL EACH TIEDOWN STRAP TO PASS UNDER THE TOP DECK BOARDS OF THE PALLET SO AS TO ENCIRCLE EACH GROUP OF THREE (3) BOXES. TIEDOWN STRAPS WILL NOT BE APPLIED UNTIL THE HORIZONTAL STRAPS ARE TENSIONED AND SEALED.
- E. THE FOLLOWING DARCOM DRAWINGS ARE APPLICABLE FOR OUTLOADING AND STORAGE OF THE ITEMS COVERED BY THIS APPENDIX.
 - CARLOADING --- DRAWING 19-48-4115-5PA1002
 - TRUCKLOADING - DRAWING 19-48-4117-11PA1003
 - STORAGE ----- DRAWING 19-48-4118-1-2-14-22PA1002
- F. FOR METHOD OF SECURING A STRAP CUTTER TO THE PALLET UNIT, SEE DARCOM DRAWING 19-48-4127-20P1000.
- G. IF ITEMS COVERED HEREIN ARE UNITIZED PRIOR TO ISSUANCE OF THIS APPENDIX, THE BOXES NEED NOT BE REUNITIZED SOLELY TO CONFORM TO THIS APPENDIX.
- H. THE UNITIZATION PROCEDURES DEPICTED HEREIN MAY ALSO BE USED FOR UNITIZING FIN, MORTAR CARTRIDGE WHEN IDENTIFIED BY A DIFFERENT NATIONAL STOCK NUMBER (NSN) THAN THOSE SHOWN ON THE TITLE PAGE, PROVIDED THE BOX PACK DOES NOT VARY FROM THOSE SHOWN HEREIN. THE EXPLOSIVE CLASSIFICATION OF OTHER ITEMS MAY BE DIFFERENT THAN THOSE SHOWN.

TIE PIECE, 1" X 4" X BOX HEIGHT (2 REQD). NAIL TO LONGITUDINAL PIECE W/2-6d NAILS AT EACH END AND TO LATERAL PIECES W/2-6d NAILS.

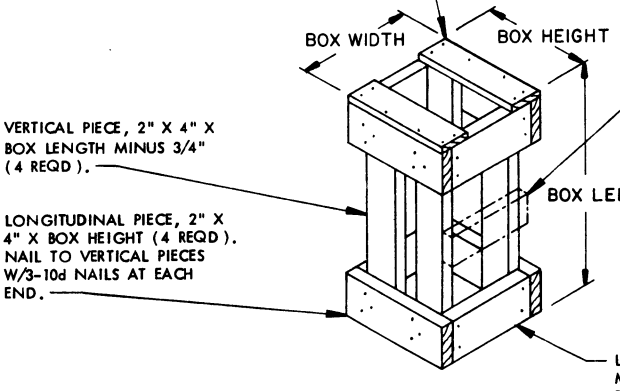

STRAP BEARING PIECE, 2" X 4" BY BOX WIDTH MINUS 3" (AS REQD). NAIL TO VERTICAL PIECES W/2-10d NAILS AT EACH END. NOTE: WHEN A UNIT HAS MORE THAN TWO (2) BOXES OMITTED, THE FILLER ASSEMBLY OR ASSEMBLIES LOCATED AT THE OUTER EDGE OF THE UNIT WILL REQUIRE A "STRAP BEARING PIECE" POSITIONED UNDER THE HORIZONTAL STRAP. STAPLE STRAP TO THE "STRAP BEARING PIECE".

FILLER ASSEMBLY
(FOR MINUS ONE BOX)