

APPENDIX 28T

UNITIZATION PROCEDURES FOR BOXED AMMUNITION AND COMPONENTS ON 4-WAY ENTRY PALLET

**CARTRIDGE, 60MM, INSENSITIVE MUNITIONS,
PACKED 16 PER WIREWOUND BOX, UNITIZED 24
BOXES PER 42" X 53" PALLET; APPROX BOX SIZE
15" L X 13-1/4" W X 20-1/4" H**

NOTICE: THIS APPENDIX CANNOT STAND ALONE BUT MUST BE USED IN CONJUNCTION WITH THE BASIC UNITIZATION PROCEDURES DRAWING 19-48-4116-20PA1002.

DISTRIBUTION STATEMENT A:

**APPROVED FOR PUBLIC RELEASE
DISTRIBUTION IS UNLIMITED.**

U.S. ARMY MATERIEL COMMAND DRAWING

APPROVED U.S. ARMY RESEARCH, DEVELOPMENT AND ENGINEERING COMMAND David A. Piskorik <small>Digitally signed by David A. Piskorik DN: cn=David A. Piskorik, c=US, email=david.a.piskorik@us.army.mil Date: 2008.06.12 09:09:45 -05'00'</small> AMSRD-AAR-AIL-TP(R)		CAUTION: VERIFY PRIOR TO USE AT WWW.DAC.ARMY.MIL THAT THIS IS THE MOST CURRENT VERSION OF THIS DOCUMENT. THIS IS PAGE 1 OF 4.			
APPROVED U.S. ARMY JOINT MUNITIONS COMMAND CASILLAS.GILBERT. J.1230393644 <small>Digitally signed by CASILLAS.GILBERT. DN: c=US, o=U.S. Government, ou=DoD, ou=PKI, ou=USA, cn=CASILLAS.GILBERT. J.1230393644 Date: 2008.06.17 13:08:38 -05'00'</small> AMSJM-LIT		DO NOT SCALE		JUNE 2001	
APPROVED BY ORDER OF COMMANDING GENERAL, U.S. ARMY MATERIEL COMMAND CARNEY.GARY. BURTON.10387 08038 <small>Digitally signed by CARNEY.GARY. DN: c=US, o=U.S. Government, ou=DoD, ou=PKI, ou=USA, cn=CARNEY.GARY. BURTON.1038708038 Date: 2008.06.18 06:47:28 -05'00'</small> U.S. ARMY DEFENSE AMMUNITION CENTER		ENGINEER OR TECHNICIAN BASIC REV.	LAURIE FIEFFER RANDY DUNN	REVISION NO. 2	JUNE 2008
TRANSPORTATION ENGINEERING DIVISON		FIEFFER.LAURA. A.1230375727 <small>Digitally signed by FIEFFER.LAURA. DN: c=US, o=U.S. Government, ou=DoD, ou=PKI, ou=USA, cn=FIEFFER.LAURA. A.1230375727 Date: 2008.05.20 07:33:20 -05'00'</small>		CLASS DIVISION DRAWING FILE	
VALIDATION ENGINEERING DIVISON		BEAVER.JERRY. W.1230949952 <small>Digitally signed by BEAVER.JERRY. DN: c=US, o=U.S. Government, ou=DoD, ou=PKI, ou=USA, cn=BEAVER.JERRY.W.1230949952 Date: 2008.05.27 12:51:52 -05'00'</small>		TESTED	
ENGINEERING DIRECTORATE		NORTUNEN.LARRY. R.1230549628 <small>Digitally signed by NORTUNEN.LARRY. DN: c=US, o=U.S. Government, ou=DoD, ou=PKI, ou=USA, cn=NORTUNEN.LARRY. R.1230549628 Date: 2008.05.20 08:00:16 -05'00'</small>		19	48
U.S. ARMY DEFENSE AMMUNITION CENTER		4116/ 28T		20PA1002	

PALLET UNIT DATA				
ITEMS INCLUDED		*HAZARD CLASS AND DIVISION	*COMPATIBILITY GROUP	APPROX WEIGHT (LBS)
NSN	DODIC			
1310-01-418-4362	BA16	1.2.2	C	2,884
01-487-1944	BA17	1.2.2	E	2,884
01-541-6210	BA28	1.2.2	E	2,980
01-541-6178	BA29	1.2.2	E	2,980

*HAZARD CLASSIFICATION DATA CONTAINED IN THE ABOVE CHART IS FOR GUIDANCE AND INFORMATIONAL PURPOSES ONLY. VERIFICATION OF THE SPECIFIED DATA SHOULD BE MADE BY CONSULTING THE MOST RECENT JOINT HAZARD CLASSIFICATION SYSTEM LISTING OR OTHER APPROVED LISTING(S).

REVISIONS

REVISION NO. 1, DATED JUNE 2002, CONSISTS OF:

ADDING ITEMS BY NATIONAL STOCK NUMBER TO "PALLET UNIT DATA" CHART.

REVISION NO. 2, DATED JUNE 2008, CONSISTS OF:

1. ADDING ITEMS BY NATIONAL STOCK NUMBER TO "PALLET UNIT DATA" CHART.
2. REMOVING THE MARINE CORPS HEIGHT RESTRICTION GENERAL NOTE IAW ECP R07K3008.

GENERAL NOTES

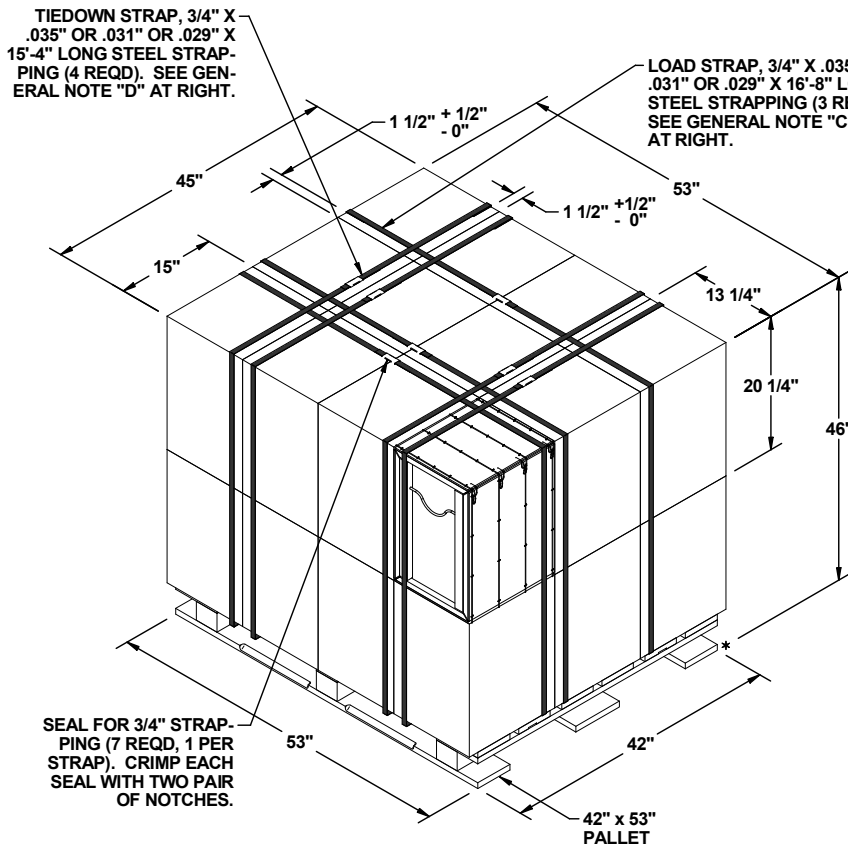

PALLET UNIT
SEE GENERAL NOTE "B" AT RIGHT.

24 BOXES OF 60MM CARTRIDGE (16 PER BOX) @ 120 LBS	---	2,880 LBS
DUNNAGE	---	10 LBS
PALLET	---	90 LBS
TOTAL WEIGHT	---	2,980 LBS (APPROX)
CUBE	---	63.5 CU FT (APPROX)

BILL OF MATERIAL		
PALLET, 42" x 53"	1 REQD	90.00 LBS
STEEL STRAPPING, 3/4"	111.33' REQD	9.94 LBS
SEAL FOR 3/4" STRAPPING	7 REQD	NIL

- A. THIS APPENDIX CANNOT STAND ALONE BUT MUST BE USED IN CONJUNCTION WITH THE BASIC UNITIZATION PROCEDURES DRAWING 19-48-4116-20PA1002. TO PRODUCE AN APPROVED UNIT LOAD, ALL PERTINENT PROCEDURES, SPECIFICATIONS AND CRITERIA SET FORTH WITHIN THE BASIC DRAWING WILL APPLY TO THE PROCEDURES DELINEATED IN THIS APPENDIX. ANY EXCEPTIONS TO THE BASIC PROCEDURES ARE SPECIFIED IN THIS APPENDIX.
- B. DIMENSIONS, CUBE AND WEIGHT OF A PALLET UNIT WILL VARY SLIGHTLY DEPENDING UPON THE ACTUAL DIMENSIONS OF THE BOXES AND THE WEIGHT OF THE SPECIFIC ITEM BEING UNITIZED.
- C. THE LOAD STRAPS MUST BE PRE-POSITIONED ON THE PALLET DECK PRIOR TO PLACING BOXES ON THE PALLET. NOTE THAT THE LOAD STRAPS WILL BE LOCATED AS SHOWN. LOAD STRAPS MUST BE TENSIONED AND SEALED PRIOR TO APPLICATION OF TIEDOWN STRAPS.
- D. INSTALL EACH TIEDOWN STRAP TO PASS UNDER THE TOP DECK BOARDS OF THE PALLET. NOTE THAT THE STRAPS WILL BE LOCATED AS SHOWN, NEAR THE SIDE CLEATS OF THE END PANELS OF THE BOX. TIEDOWN STRAPS WILL NOT BE APPLIED UNTIL THE LOAD STRAPS HAVE BEEN TENSIONED AND SEALED.
- E. THE FOLLOWING AMC DRAWINGS ARE APPLICABLE FOR OUTLOADING AND STORAGE OF THE ITEMS COVERED BY THIS APPENDIX.
 - CARLOADING - - - - 19-48-4115-5PA1002
 - TRUCKLOADING - - - - 19-48-4117-11PA1003
 - STORAGE - - - - - 19-48-4118-1-2-3-4-14-22PA1002
 - END OPENING ISO CONTAINER - - - - 19-48-4153-15PA1002
 - MILVAN - - - - - 19-48-4166-15PA1003
 - SIDE OPENING ISO CONTAINER - - - - 19-48-4267-15PA1009
- F. IF ITEMS COVERED HEREIN ARE UNITIZED PRIOR TO ISSUANCE OF THIS REVISION TO THIS APPENDIX, THE BOXES NEED NOT BE REUNITIZED SOLELY TO CONFORM TO THIS REVISION.
- G. THE UNITIZATION PROCEDURES DEPICTED HEREIN MAY ALSO BE USED FOR UNITIZING 60MM CARTRIDGES WHEN IDENTIFIED BY DIFFERENT NATIONAL STOCK NUMBERS (NSN) THAN WHAT IS SHOWN ON PAGE 2, PROVIDED THE BOX PACK DOES NOT VARY FROM WHAT IS DELINEATED HEREIN. THE EXPLOSIVE CLASSIFICATION OF OTHER ITEMS MAY BE DIFFERENT THAN WHAT IS SHOWN.
- H. THE STYLE 1B PALLET DELINEATED IN THE DETAIL AT LEFT NEED NOT HAVE CHAMFERS OR STRAP SLOTS AS SPECIFIED WITHIN MILITARY SPECIFICATION MIL-P-15011 WHEN USED FOR THE UNITIZATION OF ITEMS COVERED BY THIS APPENDIX.
- J. THE 45" LENGTH DIMENSION IS AN EXCEPTION TO THE BASIC PROCEDURES. HOWEVER, THE EXCEPTION IS NECESSARY FOR THE AMMUNITION PACK COVERED BY THIS APPENDIX TO MOST EFFECTIVELY GET AN ACCEPTABLE, COMPACT AND SOUND PALLET UNIT.
- K. FOR DETAILS OF THE MIL-B-46506 WIREBOUND BOX SEE ARDEC DRAWING 9390711.

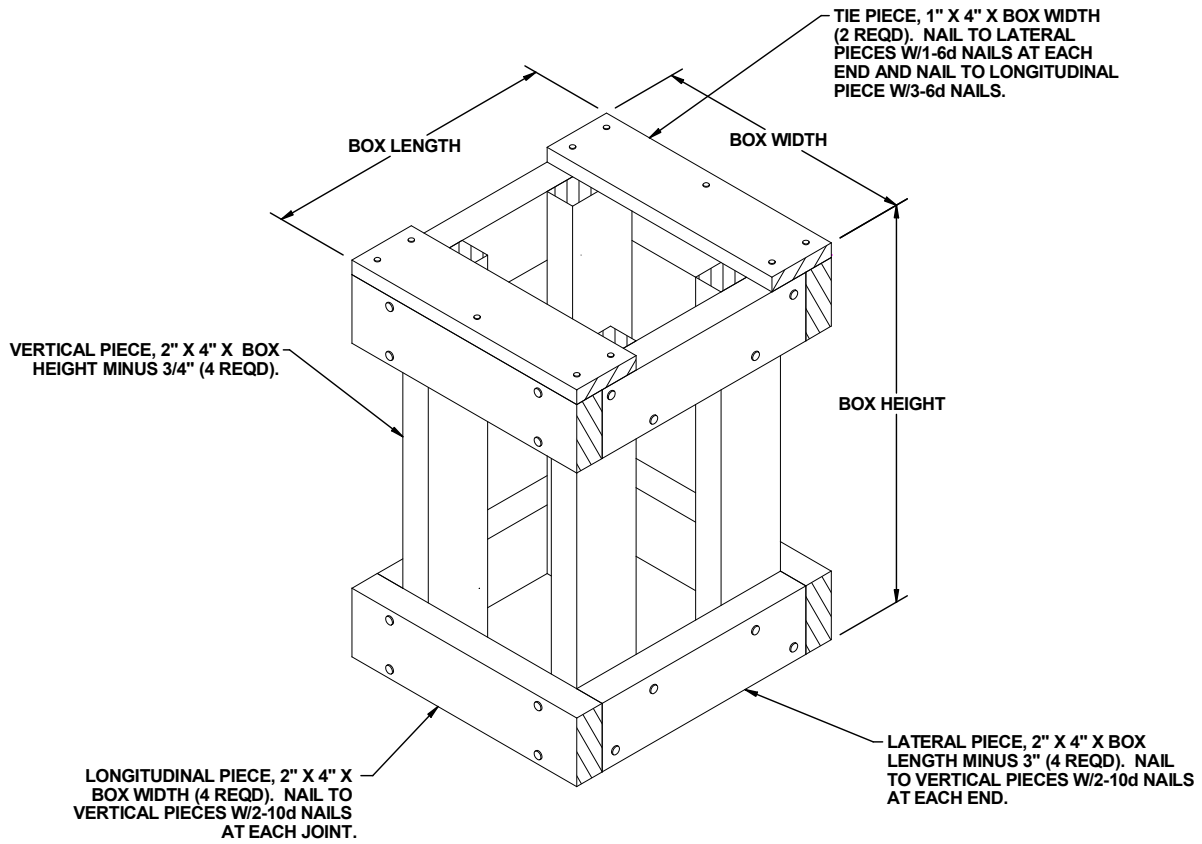

FILLER ASSEMBLY
 (FOR MINUS ONE BOX)