

# APPENDIX 28R

## UNITIZATION PROCEDURES FOR BOXED AMMUNITION AND COMPONENTS ON 4-WAY ENTRY PALLETS

CARTRIDGE, IGNITER, M702, FOR 60MM MORTAR,  
PACKED 288 PER WIREBOUND BOX, UNITIZED  
8 BOXES PER 35" X 45-1/2" PALLET; APPROX  
BOX SIZE 23-3/8" L X 17-3/8" W X 18-11/16" H

NOTICE: THIS APPENDIX CANNOT STAND ALONE BUT MUST BE USED IN CONJUNCTION WITH  
THE BASIC UNITIZATION PROCEDURES DRAWING 19-48-4116-20PA1002.

U.S. ARMY MATERIEL COMMAND DRAWING				
APPROVED, U.S. ARMY ARMAMENT, MUNITIONS AND CHEMICAL COMMAND <i>NLH</i>	DRAFTSMAN	BETTY J. KUNDERT		
	ENGINEER	SANDRA M. SCHULTZ		
<i>David A. Pinboil</i> SMCAR-ESK	<i>Timothy R. Jone</i> AMSMC-TMJ-T	SUPPLY ENGINEERING DIVISION <i>J. J. Michels</i>	TRANSPORTATION ENGINEERING DIVISION <i>W. J. ...</i>	VALIDATION ENGINEERING DIVISION <i>M. ...</i>
APPROVED BY ORDER OF COMMANDING GENERAL, U.S. ARMY MATERIEL COMMAND  <i>John L. Boyd</i>	LOGISTICS ENGINEERING OFFICE <i>William F. Ernst</i>			
U.S. ARMY DEFENSE AMMUNITION CENTER AND SCHOOL	FEBRUARY 1993			
	CLASS	DIVISION	DRAWING	FILE
	19	48	4116/ 28R	20PA 1002

DO NOT SCALE

PALLET UNIT DATA				
ITEMS INCLUDED		HAZARD CLASS AND DIVISION ●		APPROX WEIGHT LBS
NSN	DODIC	OD CLASS	COMP GROUP	
1310-01-342-6874	B617	1.4	G	503

● HAZARD CLASSIFICATION DATA CONTAINED IN THE ABOVE CHART IS FOR GUIDANCE AND INFORMATIONAL PURPOSES ONLY. VERIFICATION OF THE SPECIFIED DATA SHOULD BE MADE BY CONSULTING THE MOST RECENT JOINT HAZARD CLASSIFICATION SYSTEM LISTING OR OTHER APPROVED LISTING(S).

**GENERAL NOTES**

- A. THIS APPENDIX CANNOT STAND ALONE BUT MUST BE USED IN CONJUNCTION WITH THE BASIC UNITIZATION PROCEDURES DRAWING 19-48-4116-20PA1002. TO PRODUCE AN APPROVED UNIT LOAD, ALL PERTINENT PROCEDURES, SPECIFICATIONS AND CRITERIA SET FORTH WITHIN THE BASIC DRAWING WILL APPLY TO THE PROCEDURES DELINEATED IN THIS APPENDIX. ANY EXCEPTIONS TO THE BASIC PROCEDURES ARE SPECIFIED IN THIS APPENDIX.
- B. DIMENSIONS, CUBE AND WEIGHT OF A PALLET UNIT WILL VARY SLIGHTLY DEPENDING UPON THE ACTUAL DIMENSIONS OF THE BOXES AND THE WEIGHT OF THE SPECIFIC ITEM BEING UNITIZED.
- C. THE LOAD STRAPS MUST BE PRE-POSITIONED ON THE PALLET DECK PRIOR TO PLACING BOXES ON THE PALLET. NOTE THAT THE LOAD STRAPS WILL BE LOCATED AS SHOWN. LOAD STRAPS MUST BE TENSIONED AND SEALED PRIOR TO APPLICATION OF TIEDOWN STRAPS.
- D. INSTALL EACH TIEDOWN STRAP TO PASS UNDER THE DECK/STRINGER BOARDS OF THE PALLET AND TO BE LOCATED AS SHOWN. TIEDOWN STRAPS WILL NOT BE APPLIED UNTIL THE LOAD STRAPS HAVE BEEN TENSIONED AND SEALED.
- E. THE FOLLOWING AMC DRAWINGS ARE APPLICABLE FOR OUTLOADING AND STORAGE OF THE ITEMS COVERED BY THIS APPENDIX.
  - CARLOADING - - - - 19-48-4115-SPA1002
  - TRUCKLOADING - - - - 19-48-4117-11PA1003
  - STORAGE - - - - - 19-48-4118-1-2-3-4-14-22PA1002
  - END OPENING ISO CONTAINER - - - - 19-48-4153-15PA1002
  - MILVAN - - - - - 19-48-4166-15PA1003
  - SIDE OPENING ISO CONTAINER - - - - 19-48-4267-15PA1009
- F. FOR METHOD OF SECURING A STRAP CUTTER TO THE PALLET UNIT, SEE AMC DRAWING 19-48-4127-20P1000.
- G. IF ITEMS COVERED HEREIN ARE UNITIZED PRIOR TO ISSUANCE OF THIS APPENDIX, THE BOXES NEED NOT BE REUNITIZED SOLELY TO CONFORM TO THIS APPENDIX.
- H. THE UNITIZATION PROCEDURES DEPICTED HEREIN MAY ALSO BE USED FOR UNITIZING IGNITER CARTRIDGES WHEN IDENTIFIED BY DIFFERENT NATIONAL STOCK NUMBERS (NSN) THAN WHAT IS SHOWN ON PAGE 2, PROVIDED THE BOX PACK DOES NOT VARY FROM WHAT IS DELINEATED HEREIN. THE EXPLOSIVE CLASSIFICATION OF OTHER ITEMS MAY BE DIFFERENT THAN WHAT IS SHOWN.
- J. THE STYLE 1A PALLET DELINEATED IN THE DETAIL AT LEFT NEED NOT HAVE CHAMFERS OR STRAP SLOTS AS SPECIFIED WITHIN MILITARY SPECIFICATION MIL-P-15011 WHEN USED FOR THE UNITIZATION OF ITEMS COVERED BY THIS APPENDIX.

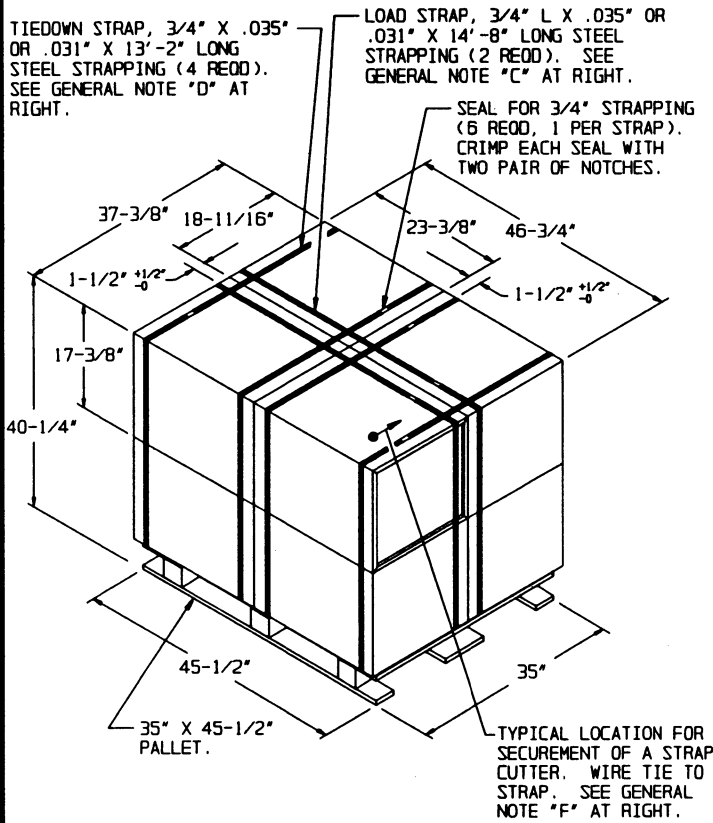

**PALLET UNIT**

SEE GENERAL NOTE "B" AT RIGHT.

8 BOXES OF IGNITER CARTRIDGES (288 PER BOX) ■ 54 LBS	- - - -	432 LBS (APPROX)
DUNNAGE	- - - - -	6 LBS
PALLET	- - - - -	65 LBS
<b>TOTAL WEIGHT</b>		<b>503 LBS</b>
<b>CUBE</b>		<b>40.7 CU FT</b>

**BILL OF MATERIAL**

PALLET, 35" X 45-1/2"	- - - -	1 REOD	- - - -	65 LBS
STEEL STRAPPING, 3/4"	- 82.00'	REOD	- - - -	5.86 LBS
SEAL FOR 3/4" STRAPPING	- - - -	6 REOD	- - - -	NIL

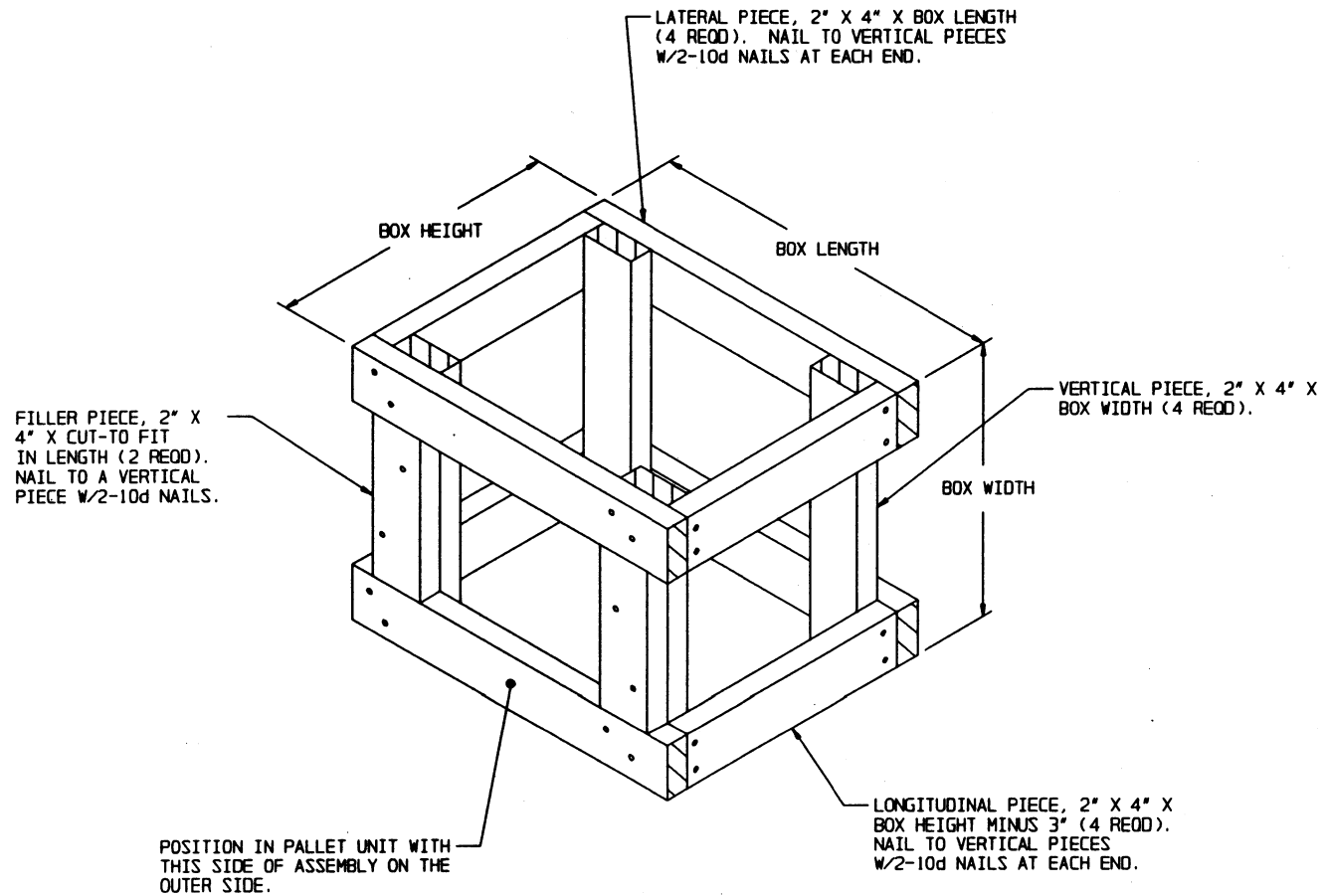

**FILLER ASSEMBLY**  
(FOR MINUS ONE BOX)