

APPENDIX 28P

UNITIZATION PROCEDURES FOR BOXED AMMUNITION AND COMPONENTS ON 4-WAY ENTRY PALLETS

CARTRIDGE, 60MM, ILLUMINATING, PACKED 16
PER WIREBOUND BOX, UNITIZED 24 BOXES PER
40" X 48" PALLET; APPROX BOX SIZE 15" L X
13-1/4" W X 20-1/4" H

NOTICE: THIS APPENDIX CANNOT STAND ALONE BUT MUST BE USED IN CONJUNCTION WITH
THE BASIC UNITIZATION PROCEDURES DRAWING 19-48-4116-20PA1002.

DISTRIBUTION STATEMENT A.

APPROVED FOR PUBLIC RELEASE:
DISTRIBUTION IS UNLIMITED.

U. S. ARMY MATERIEL COMMAND DRAWING							
APPROVED, U. S. ARMY INDUSTRIAL OPERATIONS COMMAND <i>NLH</i> <i>David A. Redmond</i> <i>Timothy Fore</i> AMSTA-AR-ESK AMSIO-TM			DRAFTSMAN BETTY J. KUNDERT		ENGINEER SANDRA M. SCHULTZ		
APPROVED BY ORDER OF COMMANDING GENERAL, U. S. ARMY MATERIEL COMMAND <i>Terry V. Dudgeon</i> U. S. ARMY DEFENSE AMMUNITION CENTER		SUPPLY ENGINEERING DIVISION <i>J. J. Michalek</i>	TRANSPORTATION ENGINEERING DIVISION <i>W. J. Friecke</i>		VALIDATION ENGINEERING DIVISION <i>J. H. Kahan</i>		
			LOGISTICS ENGINEERING OFFICE <i>William F. Ernst</i>				
			FEBRUARY 1988				
		CLASS	DIVISION	DRAWING	FILE		
REVISION NO. 1		MARCH 1997		19	48	4116/ 28P	20PA 1002
SEE THE REVISION LISTING ON PAGE 2							

DO NOT SCALE

PALLET UNIT DATA				
ITEMS INCLUDED		HAZARD CLASS AND DIVISION ●		APPROX WEIGHT LBS
NSN	DODIC	OD CLASS	COMP GROUP	
1310-				
01-258-8689	B647	(08)1.2	G	2,872
01-438-6964	BA04	(08)1.2	G	2,872

- HAZARD CLASSIFICATION DATA CONTAINED IN THE ABOVE CHART IS FOR GUIDANCE AND INFORMATIONAL PURPOSES ONLY. VERIFICATION OF THE SPECIFIED DATA SHOULD BE MADE BY CONSULTING THE MOST RECENT JOINT HAZARD CLASSIFICATION SYSTEM LISTING OR OTHER APPROVED LISTING(S).

REVISIONS

REVISION NO. 1, DATED MARCH 1997, CONSISTS OF:

1. ADDING ITEM BY NATIONAL STOCK NUMBER TO "PALLET UNIT DATA" CHART.
2. CHANGING THE WEIGHT OF THE ITEM.
3. DELETING GENERAL NOTE RELATING TO STRAP CUTTER AND RE-LETTERING OTHER GENERAL NOTES.

GENERAL NOTES

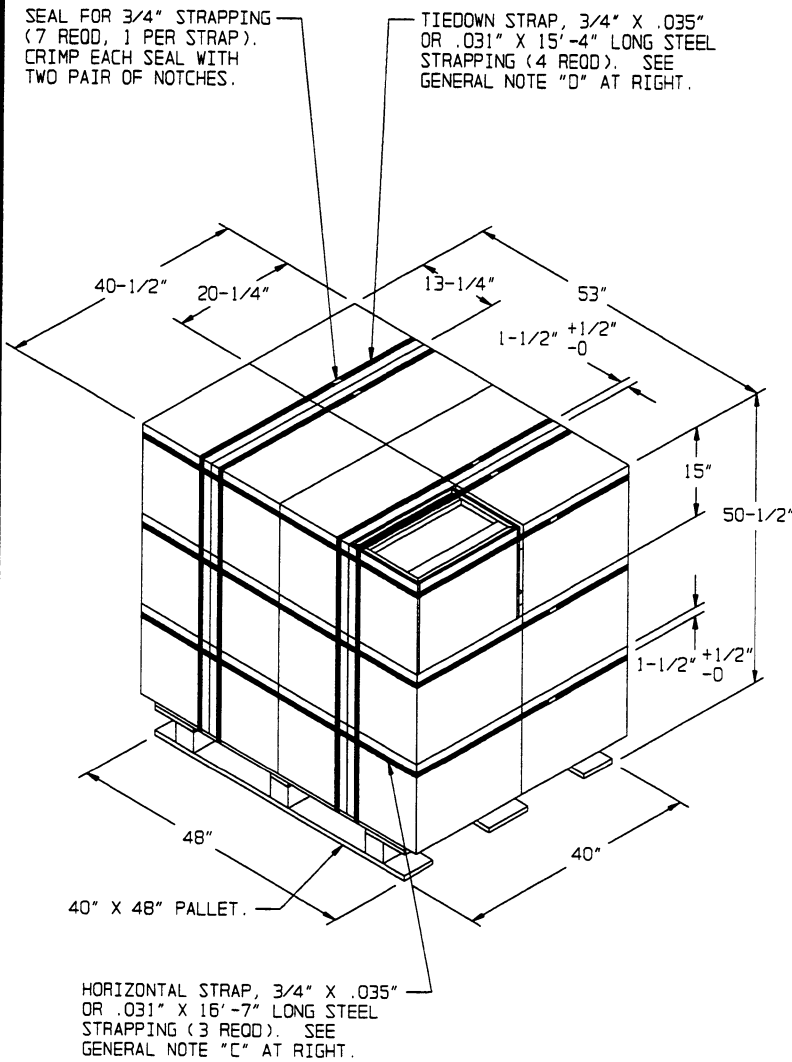

PALLET UNIT

SEE GENERAL NOTE "B" AT RIGHT.

24 BOXES OF 60MM CARTRIDGE (16 PER BOX) AT 116 LBS	---	2,784 LBS (APPROX)
DUNNAGE	-----	8 LBS
PALLET	-----	80 LBS

TOTAL WEIGHT	-----	2,872 LBS (APPROX)
CUBE	-----	62.7 CU FT (APPROX)

BILL OF MATERIAL

PALLET, 40" X 48"	-----	1 REOD	-----	80 LBS
STEEL STRAPPING, 3/4"	-----	111.08' REOD	-----	7.93 LBS
SEAL FOR 3/4" STRAPPING	-----	7 REOD	-----	NIL

- A. THIS APPENDIX CANNOT STAND ALONE BUT MUST BE USED IN CONJUNCTION WITH THE BASIC UNITIZATION PROCEDURES DRAWING 19-48-4116-20PA1002. TO PRODUCE AN APPROVED UNIT LOAD, ALL PERTINENT PROCEDURES, SPECIFICATIONS AND CRITERIA SET FORTH WITHIN THE BASIC DRAWING WILL APPLY TO THE PROCEDURES DELINEATED IN THIS APPENDIX. ANY EXCEPTIONS TO THE BASIC PROCEDURES ARE SPECIFIED IN THIS APPENDIX.
- B. DIMENSIONS, CUBE AND WEIGHT OF A PALLET UNIT WILL VARY SLIGHTLY DEPENDING UPON THE ACTUAL DIMENSIONS OF THE BOXES AND THE WEIGHT OF THE SPECIFIC ITEM BEING UNITIZED.
- C. INSTALL EACH HORIZONTAL STRAP TO ENCIRCLE A LAYER OF BOXES ON THE PALLET. NOTE THAT THE STRAPS WILL BE LOCATED AS SHOWN. HORIZONTAL STRAPS MUST BE TENSIONED AND SEALED PRIOR TO THE APPLICATION OF TIEDOWN STRAPS.
- D. INSTALL EACH TIEDOWN STRAP TO PASS UNDER THE TOP DECK BOARDS OF THE PALLET. NOTE THAT THE STRAPS WILL BE LOCATED AS SHOWN, NEAR THE SIDE CLEATS OF THE END PANELS OF THE BOX. TIEDOWN STRAPS WILL NOT BE APPLIED UNTIL THE HORIZONTAL STRAPS HAVE BEEN TENSIONED AND SEALED.
- E. THE FOLLOWING AMC DRAWINGS ARE APPLICABLE FOR OUTLOADING AND STORAGE OF THE ITEMS COVERED BY THIS APPENDIX.
 - CARLOADING - - - - 19-48-4115-5PA1002
 - TRUCKLOADING - - - - 19-48-4117-11PA1003
 - STORAGE - - - - - 19-48-4118-1-2-3-4-14-22PA1002
 - END OPENING ISO CONTAINER - - - - 19-48-4153-15PA1002
 - MILVAN - - - - - 19-48-4166-15PA1003
 - SIDE OPENING ISO CONTAINER - - - - 19-48-4267-15PA1009
- F. IF ITEMS COVERED HEREIN ARE UNITIZED PRIOR TO ISSUANCE OF THIS APPENDIX, THE BOXES NEED NOT BE REUNITIZED SOLELY TO CONFORM TO THIS APPENDIX.
- G. THE UNITIZATION PROCEDURES DEPICTED HEREIN MAY ALSO BE USED FOR UNITIZING 60MM CARTRIDGES WHEN IDENTIFIED BY DIFFERENT NATIONAL STOCK NUMBERS (NSN) THAN WHAT IS SHOWN ON PAGE 2, PROVIDED THE BOX PACK DOES NOT VARY FROM WHAT IS DELINEATED HEREIN. THE EXPLOSIVE CLASSIFICATION OF OTHER ITEMS MAY BE DIFFERENT THAN WHAT IS SHOWN.
- H. WHEN THE UNIT LOAD DEPICTED AT LEFT IS TO BE USED FOR UNITIZING MARINE CORPS AMMUNITION, ONE LAYER OF BOXES MUST BE OMITTED, TIEDOWN STRAP LENGTHS MUST BE DECREASED TO 12'-10", AND ONE HORIZONTAL STRAP MUST BE OMITTED. THIS WILL RESULT IN AN OVERALL UNIT HEIGHT OF 35-1/2", A GROSS UNIT WEIGHT OF 1,895 POUNDS, AND A UNIT CUBE OF 44.1 CUBIC FEET. ADDITIONALLY, THE UNIT MAY BE MODIFIED AS DESCRIBED WHEN BEING SHIPPED BY MILVAN OR ISO INTERMODAL FREIGHT CONTAINER. THE DETERMINATION TO REDUCE THE LOAD BY A LAYER FOR TRANSPORTATION WILL BE MADE BY THE RESPONSIBLE COMMAND AND WILL BE BASED UPON ECONOMICS OF TRANSPORTATION AND HANDLING.
- J. THE STYLE 1 PALLET DELINEATED IN THE DETAIL AT LEFT NEED NOT HAVE CHAMFERS OR STRAP SLOTS AS SPECIFIED WITHIN MILITARY SPECIFICATION MIL-P-15011 WHEN USED FOR THE UNITIZATION OF ITEMS COVERED BY THIS APPENDIX.

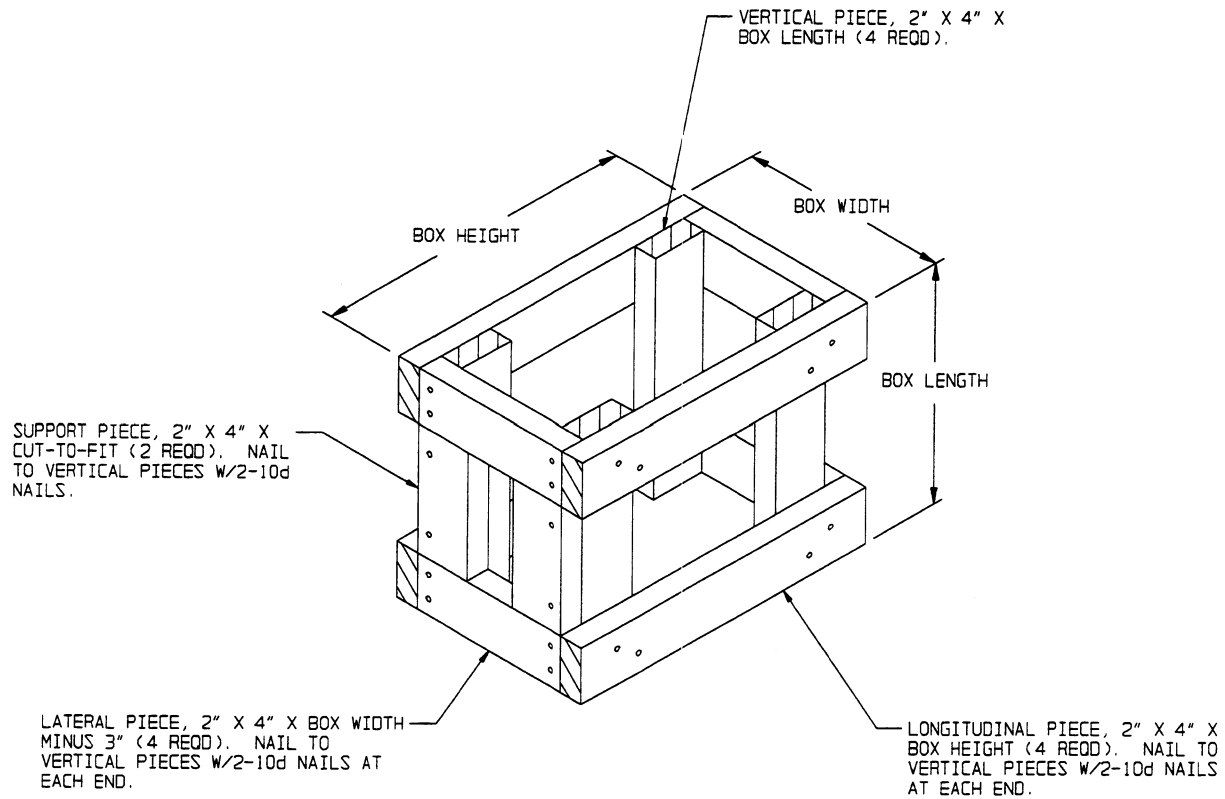

FILLER ASSEMBLY
 (FOR MINUS ONE BOX)