

APPENDIX 28N

UNITIZATION PROCEDURES FOR BOXED AMMUNITION AND COMPONENTS ON 4-WAY ENTRY PALLETS

BURSTER, PROJECTILE, M19, 60MM, PACKED 1,200
PER WOODEN BOX, UNITIZED 27 BOXES PER 35" X 45 1/2"
PALLET; APPROX BOX SIZE 15 1/2" L X 10 3/16" W X 12 21/32" H

PALLET UNIT DATA						
ITEMS INCLUDED		HAZARD CLASSIFICATION ^①				WEIGHT (LBS)
NSN	DODIC	DOT CLASS	CG CLASS	QD CLASS	COMP GROUP	
1310- 01-051-1550	—	A	X-A	1.1	D	1,718

NOTICE: THIS APPENDIX CANNOT STAND ALONE BUT MUST
BE USED IN CONJUNCTION WITH THE BASIC UNITIZATION
PROCEDURES DRAWING 19-48-4116-20PA1002.

① HAZARD CLASSIFICATION DATA CONTAINED IN THE ABOVE
CHART IS FOR GUIDANCE AND INFORMATIONAL PURPOSES
ONLY. VERIFICATION OF THE SPECIFIED DATA SHOULD BE
MADE BY CONSULTING THE MOST RECENT JOINT HAZARD
CLASSIFICATION SYSTEM LISTING OR OTHER APPROVED
LISTING (S).

DO NOT SCALE

REVISIONS				DRAFTSMAN <i>J.D./dh</i>	PROJ ENG <i>LAF/WRF</i>
				CHECKER <i>GRC</i>	LOG ENGR OFFICE <i>W.F. Ford</i>
				APPROVED, U.S. ARMY ARMAMENT, MUNITIONS AND CHEMICAL COMBAND	
				<i>Martin B. O'Keefe</i> SAC - ESK ASMC - THD	
				APPROVED BY ORDER OF COMMANDING GENERAL, U.S. ARMY MUNITIONS COMBAND (AMC)	
				<i>John X. Boyd</i> U.S. ARMY DEFENSE AMMUNITION CENTER AND SCHOOL	
U.S. ARMY AMC DRAWING					
AUGUST 1986					
CLASS	DIVISION	DRAWING	FILE		
19	48	4116/ 28N	20PA 1002		

GENERAL NOTES

- A. THIS APPENDIX CANNOT STAND ALONE BUT MUST BE USED IN CONJUNCTION WITH THE BASIC UNITIZATION PROCEDURES DRAWING 19-48-4116-20PA1002. TO PRODUCE AN APPROVED UNIT LOAD, ALL PERTINENT PROCEDURES, SPECIFICATIONS AND CRITERIA SET FORTH WITHIN THE BASIC DRAWING WILL APPLY TO THE PROCEDURES DELINEATED IN THIS APPENDIX. ANY EXCEPTIONS TO THE BASIC PROCEDURES ARE SPECIFIED IN THIS APPENDIX.
- B. DIMENSIONS, CUBE AND WEIGHT OF A PALLET UNIT WILL VARY SLIGHTLY DEPENDING UPON THE ACTUAL DIMENSIONS OF THE BOXES AND THE WEIGHT OF THE SPECIFIC ITEM BEING UNITIZED.
- C. THE LOAD STRAPS MAY BE THREADED THROUGH THE STRAP SLOTS OF A PALLET OR PRE-POSITIONED ON THE PALLET DECK PRIOR TO PLACING BOXES ON THE PALLET. LOAD STRAPS MUST BE TENSIONED AND SEALED PRIOR TO APPLICATION OF TIEDOWN STRAPS.
- D. INSTALL EACH TIEDOWN STRAP TO PASS UNDER THE TOP DECK BOARDS OF THE PALLET AND TO BE LOCATED AS SHOWN. TIEDOWN STRAPS WILL NOT BE APPLIED UNTIL THE LOAD STRAPS HAVE BEEN TENSIONED AND SEALED.
- E. THE FOLLOWING AMC (DARCOM) DRAWINGS ARE APPLICABLE FOR OUTLOADING AND STORAGE OF THE ITEMS COVERED BY THIS APPENDIX.
 CARLOADING ---- DRAWING 19-48-4115-5PA1002
 TRUCKLOADING -- DRAWING 19-48-4117-11PA1003
 STORAGE ----- DRAWING 19-48-4118-1-2-3-4-14-22PA1002
- F. FOR METHOD OF SECURING A STRAP CUTTER TO THE PALLET UNIT, SEE DARCOM DRAWING 19-48-4127-20P1000.
- G. IF ITEMS COVERED HEREIN ARE UNITIZED PRIOR TO ISSUANCE OF THIS APPENDIX, THE BOXES NEED NOT BE REUNITIZED SOLELY TO CONFORM TO THIS APPENDIX.
- H. THE UNITIZATION PROCEDURES DEPICTED HEREIN MAY ALSO BE USED FOR UNITIZING PROJECTILE BURSTERS WHEN IDENTIFIED BY DIFFERENT NATIONAL STOCK NUMBERS (NSN) THAN WHAT IS SHOWN ON THE TITLE PAGE, PROVIDED THE BOX PACK DOES NOT VARY FROM WHAT IS DELINEATED HEREIN. THE EXPLOSIVE CLASSIFICATION OF OTHER ITEMS MAY BE DIFFERENT THAN WHAT IS SHOWN.

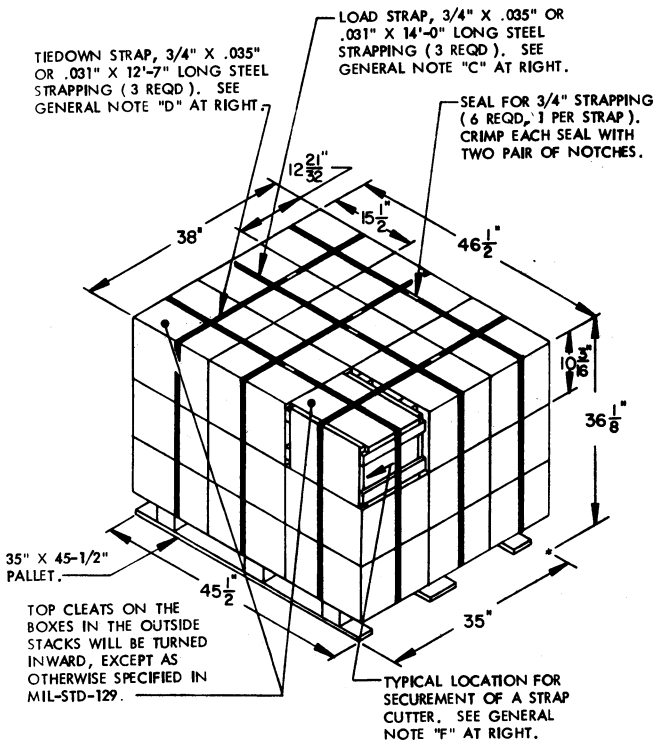

PALLET UNIT

SEE GENERAL NOTE "B" AT RIGHT.

27 BOXES OF PROJECTILE BURSTERS (1,200 PER BOX) @ 61 LBS	----	1,647 LBS (APPROX)
DUNNAGE	----	6 LBS
PALLET	----	65 LBS
TOTAL WEIGHT	----	1,718 LBS (APPROX)
CUBE	----	36.9 CU FT (APPROX)

BILL OF MATERIAL

PALLET, 35" X 45-1/2" -----	1 REQD -----	65 LBS
STEEL STRAPPING, 3/4" -----	79.75' REQD -----	5.70 LBS
SEAL FOR 3/4" STRAPPING -----	6 REQD -----	NIL

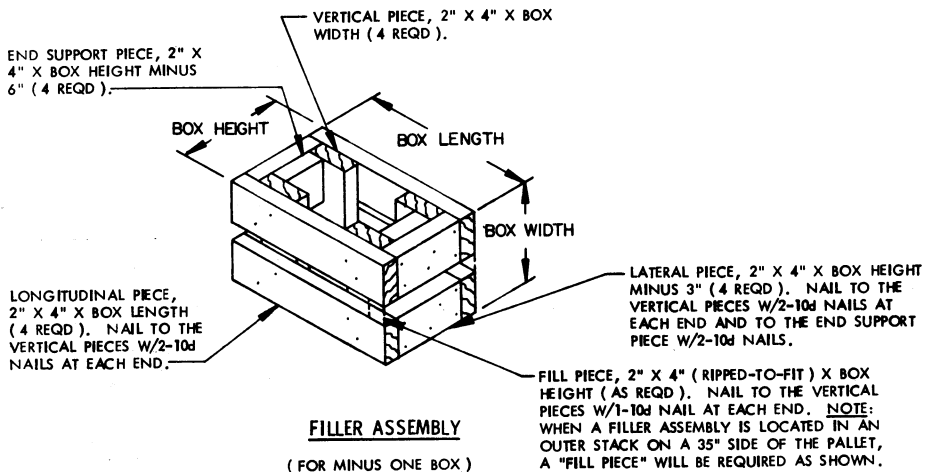

FILLER ASSEMBLY

(FOR MINUS ONE BOX)