

# APPENDIX 28L

## UNITIZATION PROCEDURES FOR BOXED AMMUNITION AND COMPONENTS ON 4-WAY ENTRY PALLETS

CARTRIDGE, 60MM, PACKED 10 PER WOODEN BOX,  
UNITIZED 4 BOXES PER 35" X 45½" PALLET;  
APPROX BOX SIZE 25<sup>7</sup>/<sub>16</sub>" L X 25<sup>7</sup>/<sub>16</sub>" W X 17<sup>7</sup>/<sub>16</sub>" H

PALLET UNIT DATA						
ITEMS INCLUDED		HAZARD CLASSIFICATION <sup>①</sup>				WEIGHT ( LBS )
NSN	DODIC	DOT CLASS	CG CLASS	QD CLASS	COMP GROUP	
UNASSIGNED		—	—	—	—	240

### REVISION

REVISION NO. 1, DATED MAY 1989, CONSISTS OF:

DELETING ITEM BY NATIONAL STOCK NUMBER FROM  
"PALLET UNIT DATA" CHART.

**NOTICE:** THIS APPENDIX CANNOT STAND ALONE BUT MUST BE USED IN  
CONJUNCTION WITH THE BASIC UNITIZATION PROCEDURES DRAWING  
19-48-4116-20PA1002.

<sup>①</sup> HAZARD CLASSIFICATION DATA CONTAINED IN THE ABOVE  
CHART IS FOR GUIDANCE AND INFORMATIONAL PURPOSES  
ONLY. VERIFICATION OF THE SPECIFIED DATA SHOULD BE  
MADE BY CONSULTING THE MOST RECENT JOINT HAZARD  
CLASSIFICATION SYSTEM LISTING OR OTHER APPROVED  
LISTING(S).

**DO NOT SCALE**

REVISIONS				DRAFTSMAN <i>K.C.B.</i>	PROJ ENG <i>RAR</i>	<i>19</i>	<i>21-91</i>
1	MAY 89	<i>W.F. Ernst</i>	<i>W.F. Ernst</i>	CHECKER <i>S.F.S.</i>	LOG ENGRG OFFICE <i>W.F. Ernst</i>		
				APPROVED U.S. ARMY ARMAMENT, MUNITIONS AND CHEMICAL COMMAND <i>Keith Benton</i> <i>A. Harrison</i>			
				DRMCG-LEP      DRMCG-TMD APPROVED BY ORDER OF COMMANDING GENERAL, U.S. ARMY MATERIEL DEVELOPMENT AND READINESS COMMAND (DARCOM) <i>John S. Boyd</i>			
				U.S. ARMY DEFENSE AMMUNITION CENTER AND SCHOOL			
				<b>U.S. ARMY DARCOM DRAWING</b>			
				<b>FEBRUARY 1984</b>			
				CLASS	DIVISION	DRAWING	FILE
				19	48	4116/ 28L	20PA 1002

PROJECT FSA 146/28L-75

**GENERAL NOTES**

- A. THIS APPENDIX CANNOT STAND ALONE BUT MUST BE USED IN CONJUNCTION WITH THE BASIC UNITIZATION PROCEDURES DRAWING 19-48-4116-20PA1002. TO PRODUCE AN APPROVED UNIT LOAD, ALL PERTINENT PROCEDURES, SPECIFICATIONS AND CRITERIA SET FORTH WITHIN THE BASIC DRAWING WILL APPLY TO THE PROCEDURES DELINEATED IN THIS APPENDIX. ANY EXCEPTIONS TO THE BASIC PROCEDURES ARE SPECIFIED IN THIS APPENDIX.
- B. DIMENSIONS, CUBE AND WEIGHT OF A PALLET UNIT WILL VARY SLIGHTLY DEPENDING UPON THE ACTUAL DIMENSIONS OF THE BOXES AND THE WEIGHT OF THE SPECIFIC ITEM BEING UNITIZED.
- C. INSTALL THE HORIZONTAL STRAP TO ENCIRCLE THE LAYER OF BOXES ON THE PALLET. HORIZONTAL STRAP MUST BE TENSIONED AND SEALED PRIOR TO APPLICATION OF TIEDOWN STRAPS.
- D. INSTALL EACH TIEDOWN STRAP TO PASS UNDER THE TOP DECK BOARDS OF THE PALLET AND TO BE LOCATED AS SHOWN. TIEDOWN STRAPS WILL NOT BE APPLIED UNTIL THE HORIZONTAL STRAP HAS BEEN TENSIONED AND SEALED.
- E. THE FOLLOWING DARCOM DRAWINGS ARE APPLICABLE FOR OUTLOADING AND STORAGE OF THE ITEMS COVERED BY THIS APPENDIX.  
 CARLOADING ----- DRAWING 19-48-4115-5PA1002  
 TRUCKLOADING ----- DRAWING 19-48-4117-11PA1003  
 STORAGE ----- DRAWING 19-48-4118-1-2-3-4-14-22PA1002
- F. FOR METHOD OF SECURING A STRAP CUTTER TO THE PALLET UNIT, SEE DARCOM DRAWING 19-48-4127-20P1000.
- G. IF ITEMS COVERED HEREIN ARE UNITIZED PRIOR TO ISSUANCE OF THIS APPENDIX, THE BOXES NEED NOT BE REUNITIZED SOLELY TO CONFORM TO THIS APPENDIX.
- H. THE UNITIZATION PROCEDURES DEPICTED HEREIN MAY ALSO BE USED FOR UNITIZING 60MM CARTRIDGES WHEN IDENTIFIED BY A DIFFERENT NATIONAL STOCK NUMBER (NSN) THAN WHAT IS SHOWN ON THE TITLE PAGE, PROVIDED THE BOX PACK DOES NOT VARY FROM WHAT IS DELINEATED HEREIN. THE EXPLOSIVE CLASSIFICATION OF OTHER ITEMS MAY BE DIFFERENT THAN WHAT IS SHOWN.
- J. IF THERE IS A NEED TO USE FILLER ASSEMBLIES AND AT LEAST TWO PALLET UNITS ARE BEING CONSTRUCTED, NOT MORE THAN TWO FILLERS WILL BE INSTALLED IN ANY ONE PALLET UNIT. USING TWO PALLET UNITS TO SATISFY THE PALLETIZATION CRITERIA APPLICABLE TO LESS-THAN-FULL PALLET UNITS IS AN EXCEPTION TO THE BASIC PROCEDURES. HOWEVER, THE EXCEPTION IS NECESSARY FOR THE AMMUNITION PACK COVERED BY THIS APPENDIX, TO MOST EFFECTIVELY GET AN ACCEPTABLE, COMPACT AND SOUND PALLET UNIT.

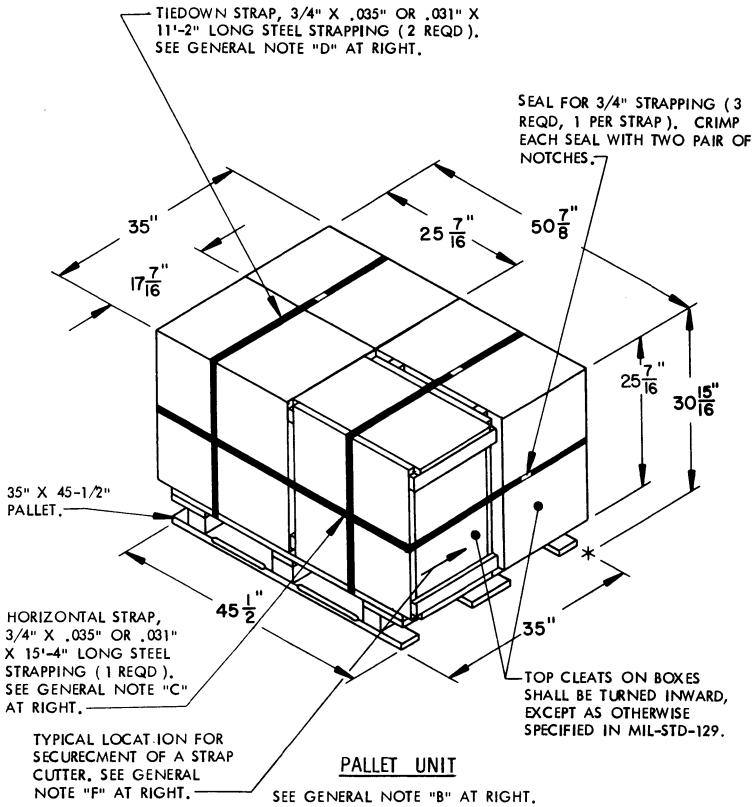

4 BOXES 60MM CARTRIDGES ( 10 PER BOX ) @ 43 LBS -----	172 LBS ( APPROX )
DUNNAGE -----	3 LBS
PALLET -----	65 LBS
<b>TOTAL WEIGHT -----</b>	<b>240 LBS ( APPROX )</b>
<b>CUBE -----</b>	<b>31.9 CU. FT.</b>

BILL OF MATERIAL		
PALLET, 35" X 45-1/2" -----	1 REQD -----	65 LBS
STEEL STRAPPING, 3/4" -----	37.67 REQD -----	2.69 LBS
SEAL FOR 3/4" STRAPPING -----	3 REQD -----	NIL

