

APPENDIX 28G

UNITIZATION PROCEDURES FOR BOXED AMMUNITION AND COMPONENTS ON 4-WAY ENTRY PALLETS

CARTRIDGE, 60MM, PACKED 8 PER METAL BOX,
UNITIZED 45 BOXES PER 40" X 48" PALLET;
APPROX BOX SIZE 13 $\frac{3}{4}$ " L X 9 $\frac{3}{4}$ " W X 9 $\frac{3}{4}$ " H

PALLET UNIT DATA						
ITEMS INCLUDED		HAZARD CLASSIFICATION				WEIGHT (LBS)
NSN	DODIC	DOT CLASS	CG CLASS	QD CLASS	COMP GROUP	
1310-00-542-0384	B632	A	IV	(08)1.2	E	1,978

NOTICE: THIS APPENDIX CANNOT STAND ALONE BUT MUST
BE USED IN CONJUNCTION WITH THE BASIC UNITIZATION
PROCEDURES DRAWING 19-48-4116-20PA1002.

REVISIONS				DRAFTSMAN <i>GRG/alk</i>	PROJ. ENG. <i>WRF/new</i>
				CHECKER <i>RSN/B.B.</i>	LOG ENGRS OFFICE <i>John Boyd</i>
<small>APPROVED, U. S. ARMY ARMAMENT MATERIEL READINESS COMMAND</small>					
				<i>San Antonio Kuster</i> <small>DARCOM - MAD</small>	<i>D.C. Feller</i> <small>DARCOM - TMD</small>
<small>APPROVED BY ORDER OF COMMANDING GENERAL, U. S. ARMY MATERIEL DEVELOPMENT AND READINESS COMMAND (DARCOM)</small>					
<i>John A. Reynolds</i> <small>U. S. ARMY DEFENSE AMMUNITION CENTER AND SCHOOL</small>					
U. S. ARMY DARCOM DRAWING					
JUNE 1980					
CLASS	DIVISION	DRAWING	FILE		
19	48	4116/28G	20PA 1002		

DO NOT SCALE

GENERAL NOTES

- A. THIS APPENDIX CANNOT STAND ALONE BUT MUST BE USED IN CONJUNCTION WITH THE BASIC UNITIZATION PROCEDURES DRAWING 19-48-4116-20PA1002. TO PRODUCE AN APPROVED UNIT LOAD, ALL PERTINENT PROCEDURES, SPECIFICATIONS AND CRITERIA SET FORTH WITHIN THE BASIC DRAWING WILL APPLY TO THE PROCEDURES DELINEATED IN THIS APPENDIX. ANY EXCEPTIONS TO THE BASIC PROCEDURES ARE SPECIFIED IN THIS APPENDIX.
- B. DIMENSIONS, CUBE AND WEIGHT OF A PALLET UNIT WILL VARY SLIGHTLY DEPENDING UPON THE ACTUAL DIMENSIONS OF THE BOXES AND THE WEIGHT OF THE SPECIFIC ITEM BEING UNITIZED.
- C. THE LOAD STRAPS MAY BE THREADED THROUGH THE STRAP SLOTS OF A PALLET OR PRE-POSITIONED ON THE PALLET DECK PRIOR TO PLACING BOXES ON THE PALLET.
- D. INSTALL EACH TIEDOWN STRAP TO PASS UNDER THE DECK/STRINGER BOARDS OF THE PALLET AND TO BE LOCATED AS SHOWN. TIEDOWN STRAPS WILL NOT BE APPLIED UNTIL THE LOAD STRAPS HAVE BEEN TENSIONED AND SEALED.
- E. THE FOLLOWING DARCOM DRAWINGS ARE APPLICABLE FOR OUTLOADING AND STORAGE OF THE ITEMS COVERED BY THIS APPENDIX.
 - CARLOADING ----- DRAWING 19-48-4115-5PA1002
 - TRUCKLOADING ----- DRAWING 19-48-4117-11PA1003
 - STORAGE ----- DRAWING 19-48-4118-1-2-14-22PA1002
- F. FOR METHOD OF SECURING A STRAP CUTTER TO THE PALLET UNIT, SEE DARCOM DRAWING 19-48-4127-20P1000.
- G. IF ITEMS COVERED HEREIN ARE UNITIZED PRIOR TO ISSUANCE OF THIS APPENDIX, THE BOXES NEED NOT BE REUNITIZED SOLELY TO CONFORM TO THIS APPENDIX.
- H. THE UNITIZATION PROCEDURES DEPICTED HEREIN MAY ALSO BE USED FOR UNITIZING 60MM CARTRIDGES WHEN IDENTIFIED BY DIFFERENT NATIONAL STOCK NUMBERS (NSN) THAN WHAT IS SHOWN ON THE TITLE PAGE, PROVIDED THE BOX PACK DOES NOT VARY FROM WHAT IS DELINEATED HEREIN. THE EXPLOSIVE CLASSIFICATION OF OTHER ITEMS MAY BE DIFFERENT THAN WHAT IS SHOWN.

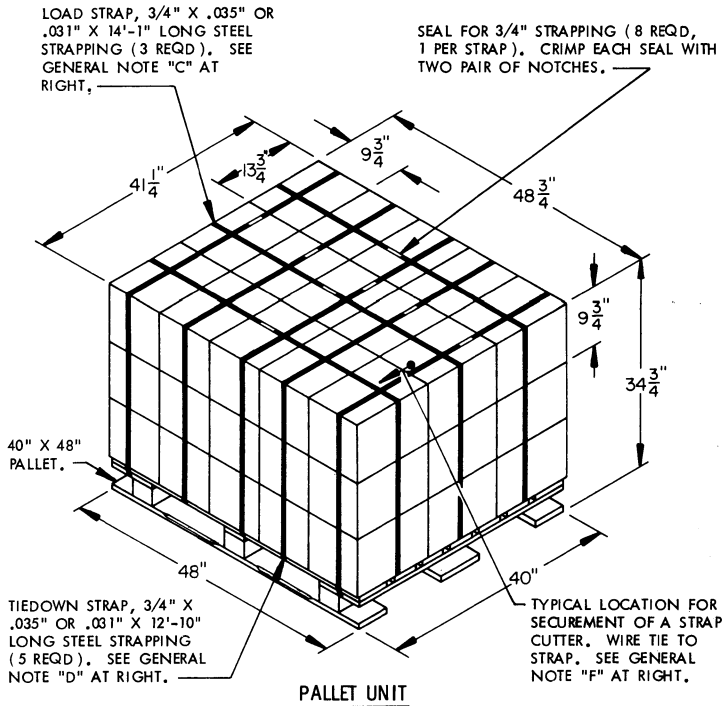

SEE GENERAL NOTE "B" AT RIGHT.

45 BOXES OF 60MM CARTRIDGES (8 PER BOX) @ 42 LBS -----	1,890 LBS (APPROX)
DUNNAGE -----	8 LBS
PALLET -----	80 LBS
TOTAL WEIGHT -----	1,978 LBS (APPROX)
CUBE -----	40.4 CU FT (APPROX)

BILL OF MATERIAL

PALLET, 40" X 48" -----	1 REQD -----	80 LBS
STEEL STRAPPING, 3/4" -----	106.42' REQD -----	7,60 LBS
SEAL FOR 3/4" STRAPPING -----	8 REQD -----	NIL

